



5" Oval Nerf Bar

Part No. A7005S/B



Fits: **2002-2008**
2003-2009

Dodge Ram 1500 Quad Cab
Dodge Ram 2500/3500 Quad Cab



Excl. C/K "Classic"



REMOVE CONTENTS FROM BOX. VERIFY ALL PARTS ARE PRESENT.



READ INSTRUCTIONS CAREFULLY BEFORE STARTING INSTALLATION.

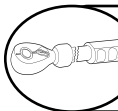

DO NOT OVER TORQUE. STANDARD OPERATING LOAD FOR TIGHTEN BODY MOUNT NUTS & BOLTS VARIES FROM 45 TO 65 FOOT POUND.



60-180 min

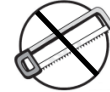

Cutting Not Required



Drilling Not Required



support@trailfx.com



1 866 638 4870



POLISHED STAINLESS STEEL – LIMITED LIFETIME
POWDER COATED BLACK – 3 YEARS

PARTS LIST:

Qty	Part Description	Qty	Part Description
1	Driver/Left Sidebar	4	10mm x 35mm Bolt Plates
1	Passenger/Right Sidebar	4	12-1.75mm x 120mm Gr.10.9 Hex Bolts
1	Driver/Left Front Mounting Bracket	4	12mm x 32mm OD x 3mm Flat Washers
1	Passenger/Right Front Mounting Bracket	4	12mm Lock Washers
1	Driver/Left Rear Mounting Bracket	4	10-1.5mm x 30mm Hex Bolts
1	Passenger/Right Rear Mounting Bracket	12	10mm x 30mm OD x 2.5mm Flat Washers
1	Driver/Left Front Support Bracket	8	10mm Lock Washers
1	Passenger/Right Front Support Bracket	8	10mm Hex Nuts
1	Driver/Left Rear Support Bracket	8	8-1.25mm x 25mm Hex Bolts
1	Passenger/Right Rear Support Bracket	8	8mm Lock Washers
4	12mm x 48mmOD x 5mm Spacers	8	8mm x 24mm OD x 2mm Flat Washers
4	10mm Plastic Retainers		

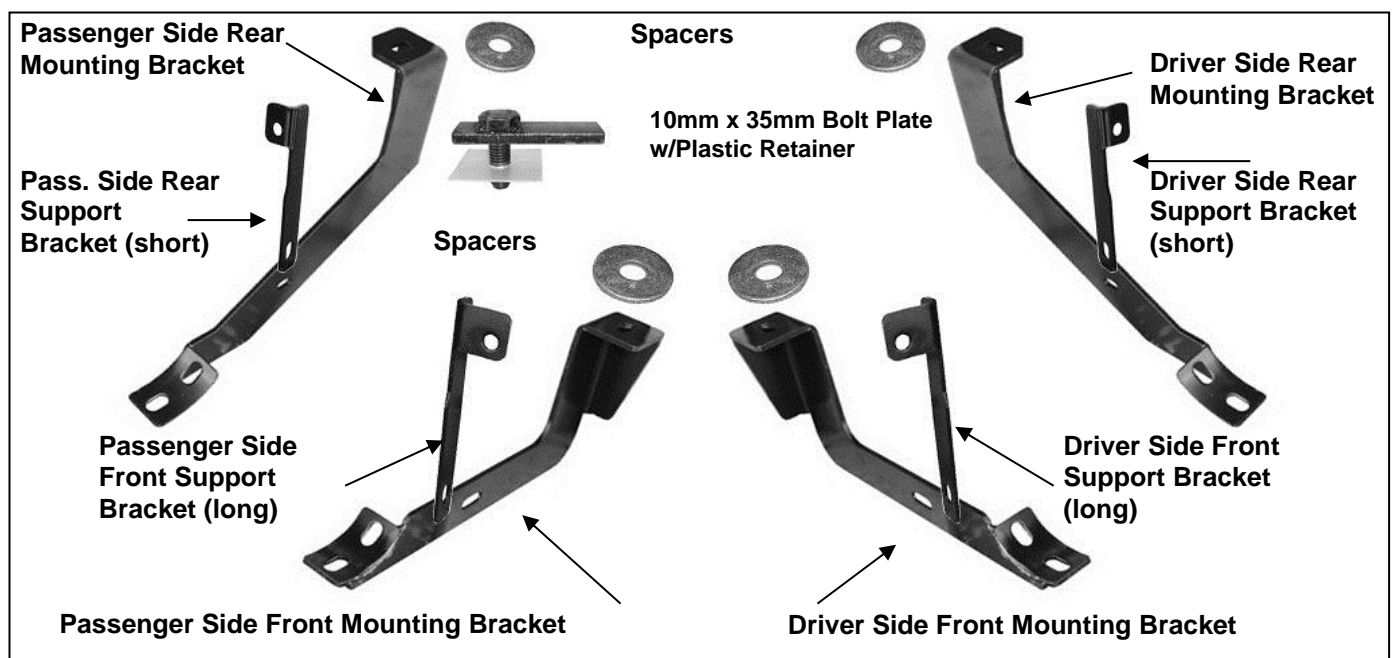

INSTALLATION PROCEDURE:

1. Starting toward the front of the driver side, remove the factory front body mount bolt with attached washer. Remove but do not discard the factory rubber bushing from the factory bolt.
2. Select the driver side front Mounting Bracket. Insert (1) 12-1.75mm x 120mm Hex Bolt with (1) 12mm ID x 32mm OD x 3mm Flat Washer and (1) 12mm Lock Washer through the Mounting Bracket. Place (1) Spacer Plate onto the 12mm Hex Bolt then slide the rubber bushing onto the Hex Bolt. Make sure that the Spacer Plate is between the Mounting Bracket and the factory rubber bushing, **(Figure 3)**. Hold the front Mounting Bracket, (with hardware, factory washer and rubber bushing), up in position and hang it from the body mount by threading the hex bolt into the body mount. Snug but do not tighten hardware at this time. **IMPORTANT:** On 05 and newer model years, the large washer on the factory body mount bolt is removable, (do not discard-must reinstall), and the bolt is long enough to go through the Mounting Bracket and properly thread into the body mount. It is the installer's responsibility to check length and to determine whether to use the factory or replacement hex bolt.
3. Repeat Steps 2-3 for rear Mounting Bracket installation.
4. Remove the tape covering the factory hole in the back side of the rocker panel near the Mounting Bracket. Thread (1) Plastic Retainer part way onto (1) 10mm x 35mm Bolt Plate. Insert the Bolt Plate into the factory hole in the rocker panel, **(Figure 1)**. Hold the Bolt Plate in place with one hand and continue to thread the Plastic Retainer down against the sheet metal until it holds the Bolt Plate in place, **(Figure 2)**. **IMPORTANT:** The Plastic Retainer is designed to prevent the Bolt Plate from falling into the body cavity and to aid in installing the Bracket.
5. Locate the driver side front Support Bracket (long) and attach it to the Bolt Plate with (1) 10mm Lock Washer, (1) 10mm Flat Washer and (1) 10mm Hex Nut, **(Figure 3)**. **NOTE:** Place Support Bracket against the front facing side of the Mounting Bracket with the bent tab facing towards the **front** of the vehicle. Snug but do not tighten hardware at this time.
6. Attach the lower end of the front Support Bracket to the Mounting Bracket using (1) 10mm x 30mm Hex Head Bolt, (1) 10mm Lock Washer, (2) 10mm Flat Washers and (1) 10mm Hex Nut, **(Figure 3)**. Do not tighten hardware at this time.
7. Next, move to the rear Mounting Bracket location. Remove the tape covering the hole in the inner rocker panel and install (1) Bolt Plate as described in **Step 5**. Locate the driver side rear Support Bracket (short) and attach it to the Bolt Plate with (1) 10mm Lock Washer, (1) 10mm Flat Washer and (1) 10mm Hex Nut, **(Figure 4)**. **NOTE:** Place Support Bracket against the front facing side of the Mounting Bracket with the bent tab facing towards the **rear** of the vehicle. Repeat **Step 7** to attach the lower end of the Support Bracket to the Mounting Bracket, **(Figure 4)**. Snug but do not tighten hardware at this time
8. With assistance, carefully position the driver Sidebar onto the Mounting Brackets. Partially attach the Sidebar to the front and rear Mounting Brackets with the included (4) 8mm x 25mm Hex Head Bolts, (4) 8mm Lock Washers, and (4) 8mm Flat Washers, **(Figure 5)**. Do not tighten hardware at this time.
9. Properly level and adjust the Sidebar and tighten all hardware at this time.
10. Repeat steps 2-10 for the passenger/right sidebar installation.
11. Do periodic inspections to the installation to make sure that all hardware is secure and tight.

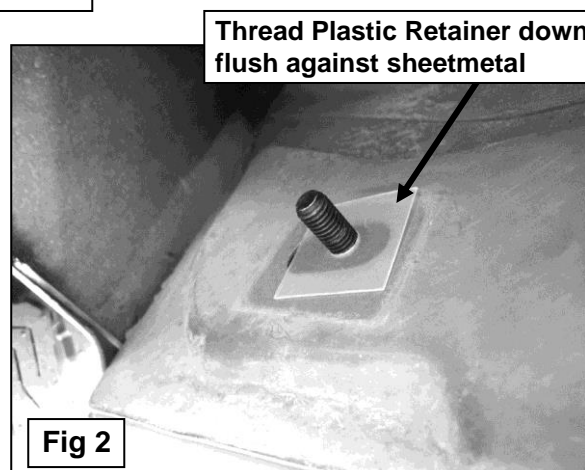
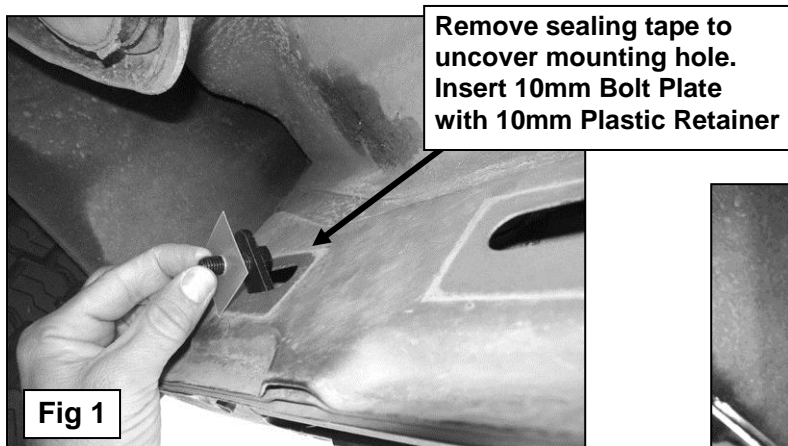
Driver Side Installation Pictured

Driver Side Installation Pictured

IMPORTANT: Insert (1) Steel Spacer between each front and rear Mounting Bracket and factory rubber bushing (driver side front Mounting Bracket pictured)

Spacer

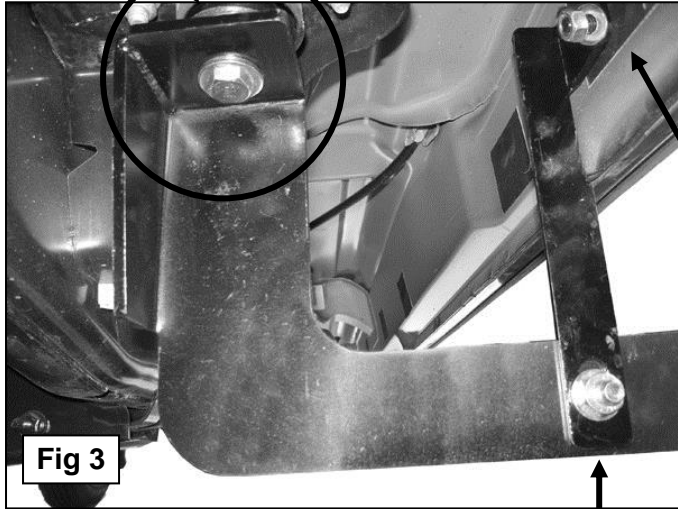

Fig 3

10mm x 35mm Bolt Plate
10mm Flat Washer
10mm Lock Washer
10mm Hex Nut

IMPORTANT: Insert (1) Steel Spacer between each front and rear Mounting Bracket and factory rubber bushing (driver side rear Mounting Bracket pictured)

10mm x 30mm Hex Bolt
10mm Flat Washer
10mm Lock Washer
10mm Hex Nut

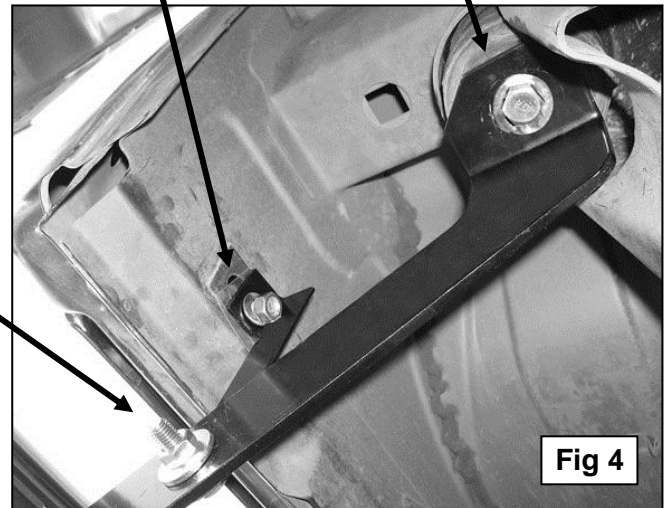

Fig 4

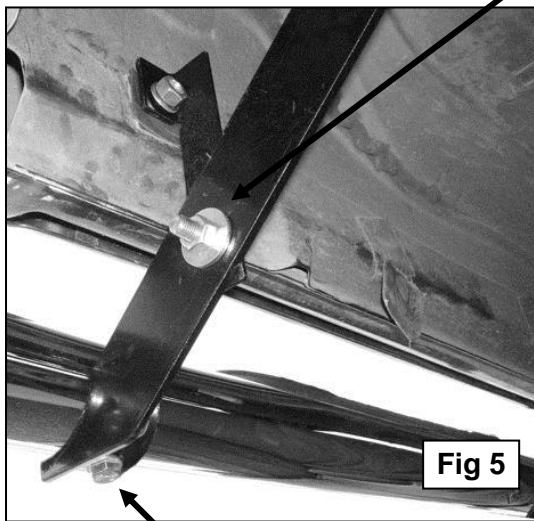

Fig 5

8mm x 25mm Hex Bolt
8mm Flat Washer
8mm Lock Washer



Complete Installation

PARTS IDENTIFICATION GUIDE

Driver Side tube packed using "Green" color foam sheet. Passenger Side tube packed using "White" color foam sheet

No.	Parts Identification
1	Passenger / Right 'Rear' Bracket marked "PR"
2	Driver / Left 'Rear' Bracket marked "DR"
3	Passenger / Right 'Center' Bracket marked "PC"
4	Driver / Left 'Center' Bracket marked "DC"
5	Passenger / Right 'Front' Bracket marked "PF"
6	Driver / Left 'Front' Bracket marked "DF"

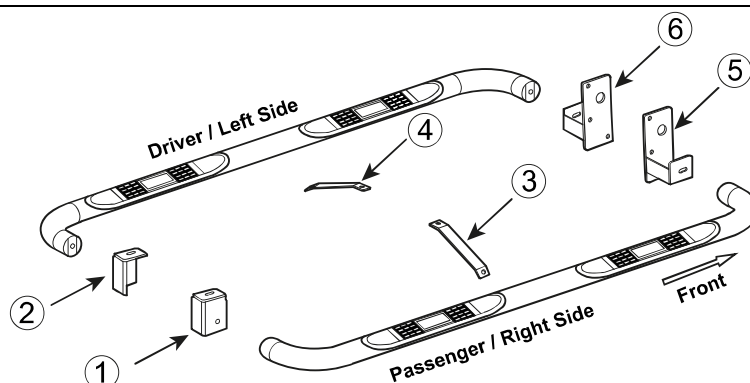
**Note:**

- > This guide is to identify the parts and not a reference for part count.
- > For part count, refer Parts List.
- > Product / Bracket image is representative and actual design may vary.

PRODUCT CARE

- Periodically check the product to ensure all fasteners are tight and components are intact.
- Regular waxing is recommended to protect the finish of the product.
- **Use ONLY Non-Abrasive automotive wax.** Use of any soap, polish or wax that contains an abrasive is detrimental and can scratch the finish leading to corrosion.
- Aluminum polish may be used to polish small scratches and scuffs for **Stainless Steel finish.**
- Mild soap may be used to clean the product for both **Stainless Steel and Black finish.**

FAQ's**1. Hardware's are not of correct size.**

In GMC / Chevrolet truck model 2006 & up, customer needs to reuse the factory body bolts to install the bracket. If your vehicle is not GMC / Chevrolet 2006 & up, ensure that holes are not partially covered with any plastic grommet or rust? If it is, remove the plastic grommet & rust from the thread holes & re-try the installation.

2. Mounting Bracket are not getting Installed properly.

In some cases Illustration images shown in Installation manual may not be the exactly same as per actual vehicle images ,also if Driver / Passenger side mounting brackets are very identical in the design, suggest referring Parts Identification guide to avoid fitment issue.

3. Products are thumping / rattling after installation.

Ensure that all required mounting brackets / hardware's are installed & tighten correctly. Suggest using white lithium / regular grease between the metal to metal contact surfaces.

4. Side Bar is not aligning with vehicle / Step Pads are not aligning with vehicle doors.

Side bar may be interchanged or mounting brackets are not installed at the correct position in the vehicle. Refer Parts identification guide.

5. Missing / Excess Hardware.

Recheck hardware count as per the part list.

6. Product not installing properly.

Ensure make model year, cab length and bed size of your vehicle is listed in the application. All installation steps are followed correctly.

Check out these other TrailFX Products!!

www.TrailFX.com



BULL BAR



GRILLE GUARDS



BED RAILS



RUNNING BOARDS

Keystone Automotive Operations Inc. (KAO) warrants this product to be free of defects in material and workmanship at the time of purchase by the original retail consumer. KAO disclaims any other warranties, express or implied, including the warranty of fitness for a particular purpose or an intended use. If the product is found to be defective, KAO may replace or repair the product at our option, when the product is returned prepaid, with proof of purchase. Alteration to, improper installation, or misuse of this product voids the warranty. KAO's liability is limited to repair or replacement of products found to be defective, and specifically excludes liability for any incidental or consequential loss or damage.