

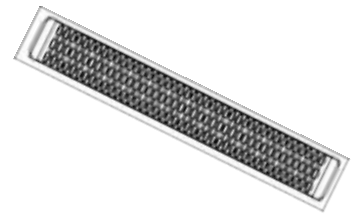

Aggressive Running Board -Van

Part No. ARBV002B



Fits: **2015-Current**

Ford Transit (32"+32")



TRANSIT VAN WITH DOUBLE SLIDING DOORS FOR FIRST SEATS (FULL SIZE)



REMOVE CONTENTS FROM BOX. VERIFY ALL PARTS ARE PRESENT.



READ INSTRUCTIONS CAREFULLY BEFORE STARTING INSTALLATION.

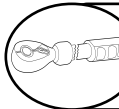

DO NOT OVER TORQUE. STANDARD OPERATING LOAD FOR TIGHTEN BODY MOUNT NUTS & BOLTS VARIES FROM **45** TO **65** FOOT POUND.



60-180 min



Cutting Required



Drilling Required



support@trailfx.com



1 866 638 4870



POLISHED STAINLESS STEEL – LIMITED LIFETIME
POWDER COATED BLACK – 3 YEARS

PARTS LIST:

Qty	Part Description	Qty	Part Description
2	Aggressive Running Boards (32")	4	8mm Nylon Lock Nuts
2	Front Brackets	8	8mm "U" Clips
2	Rear Brackets	10	8-1.25mm x 25mm Hex Bolt
4	8mm Double Bolt Plates	1	8-1.25mm x 35mm Hex Bolt
18	8mm Lock Washers	2	8mm Insert Nut
23	8mm x 24mm x 2mm Flat Washers	2	8mm U-Bolts
9	8mm Hex Nuts	1	8mm Insert Tool

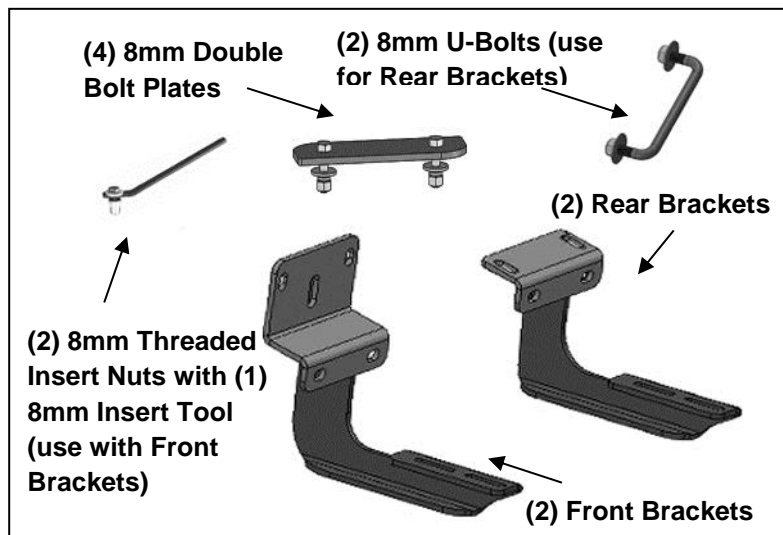

INSTALLATION PROCEDURE:**DRILLING IS REQUIRED. ASSISTANCE IS RECOMMENDED.**

1. Start the installation under the driver side of the vehicle. Release the lower clips from the plastic trim along the bottom of the body, **(Figure 1)**. **NOTE:** From below, insert a small or medium sized flat blade screwdriver into the rectangular hole in the center of the clip. Carefully release each side (inside to outside, not front to back) of the plastic clip and pull the rectangular center pin down from the clip, **(Figure 2)**. Do not twist the clip, gently pull it straight down once it is released. It is not necessary to completely remove the trim, only release the clips attaching the bottom of the trim to the vehicle.
2. Identify the front bracket mounting location approximately 10" back from the front corner of the body, **(Figure 3)**. Remove excess undercoating from all mounting locations so that Brackets will install flat against body panel and pinch weld.
3. Select (1) Front Bracket. Hold the Bracket firmly in position against the bottom and side of the body panel and mark the top left slot location onto the inner body panel. Also, mark the location of the (2) bottom slots in the Bracket onto the pinch weld, **(Figure 3)**. **IMPORTANT:** Do not drill through the welds in the pinch weld. Slide the Bracket forward or back to move the slots away from the factory spot welds. Do not drill into or through the outer plastic rocker panel cover. Remove the Bracket.
4. Drill a 7/16" hole through the body panel for the top left slot of the Bracket, **(Figures 3 & 6B)**. Select (1) 8mm Threaded Insert, (1) 8mm x 35mm Hex Bolt, (1) 8mm Hex Nut, (1) 8mm Flat Washer and (1) 8mm Insert Tool. Thread the Hex Nut onto the Hex Bolt. Assemble the Tool as pictured in **Figure 4**. Use a 13mm wrench to hold the Hex Bolt to prevent it from spinning. Turn the Hex Nut counter-clockwise to pull/expand the insert in the hole, **(Figure 5)**. Tighten the Hex Nut until the Insert is fully installed, **(Figures 6A & 6B)**. Do not overtighten the Hex Nut.
5. Next, use a 3/8" drill bit to drill (2) holes through the pinch weld only. **NOTE:** Drill the holes as far away from the bottom edge of the pinch weld as possible

IMPORTANT! Any cutting or drilling tool may break or shatter. Government regulations require safety glasses & equipment at all times when cutting or drilling.

6. Select (2) 8mm U-Clips. Slide the U-Clips over the pinch weld with the nut toward the outside, **(Figure 6B)**. Attach the (2) bottom slots of the Bracket to the pinch weld with (2) 8mm x 25mm Hex Bolts, (2) 8mm Lock Washers and (2) 8mm Flat Washers, **(Figure 8)**. Leave hardware loose at this time.
7. Attach the (1) top left slot of the bracket to the previously installed Threaded Insert with (1) 8mm x 25mm Hex Bolts, (1) 8mm Lock Washers and (1) 8mm Flat Washers, **(Figure 8)**. Leave hardware loose at this time.
8. Continue along the side of the body to the driver side rear mounting location approximately 24" back from the front corner of the body, **(Figures 3 & 9)**. Select the rear Mounting Bracket. Hold the Bracket firmly against the bottom and back of the body panel. Slide the Bracket forward or back as necessary to avoid drilling through any welds on the pinch weld. Mark all (4) locations to drill.
9. Drill (2) 7/16" holes through the bottom of the body panel as marked, **(Figure 10)**. Next, repeat **Step 5** to drill through the pinch weld to attach the bottom of the Bracket. Insert (1) 8mm U-Bolt into and through the (2) drilled 7/16" holes. Select (1) Rear Bracket. Attach the top slots on the Bracket to the U-Bolt with (2) 8mm Flat Washers and (2) 8mm Nylon Lock Nuts, **(Figure 11 & 12)**. Repeat **Step 6** to drill and attach the bottom of the Bracket to the back of the pinch weld. Leave all hardware loose.
10. Select (2) 8mm Double Bolt Plates. Locate the channels in the bottom of the Running Board, **(Figure 13)**. Insert the Bolt Plates into the channels in the bottom of the Running Board closest to the Brackets. Lift the Running Board up and guide the studs through the Brackets.
11. Select (1) Running Board. Attach the Running Board to the Brackets with (4) 8mm Flat Washers, (4) 8mm Lock Washers and (4) 8mm Hex Nuts, **(Figure 14)**. **NOTE:** The Running Board is designed to fit close to the vehicle. It may be necessary to loosen the Bracket hardware and tilt the Brackets downward to insert the Running Board between the Brackets and the body. Do not tighten hardware.
12. Repeat **Steps 1—11** to install Passenger/right side front and rear bracket and running board.
 - a. **NOTE:** Use the top right slot of the front bracket to install threaded insert, **Figure (7)**.
13. Level and adjust the Running Board and fully tighten all hardware. Reinstall the plastic trim along the bottom of the body. **IMPORTANT:** Minor trimming may be required around 8mm U-Clips. Use a sharp knife or hacksaw blade to trim plastic as required.
14. Do periodic inspections to the installation to make sure that all hardware is secure and tight.

Driver/Left Side Installation Picture

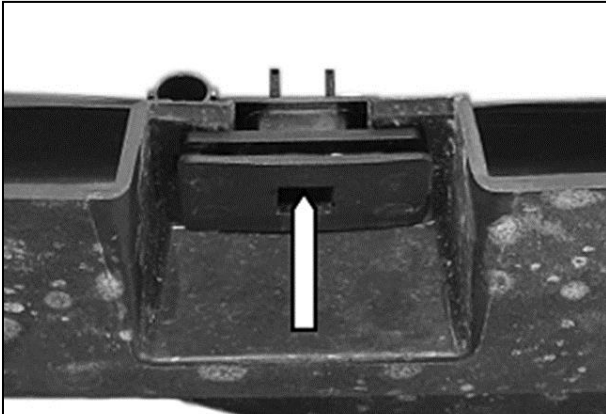

(Fig 1) Insert flat blade screwdriver into square opening in center of plastic clip to release

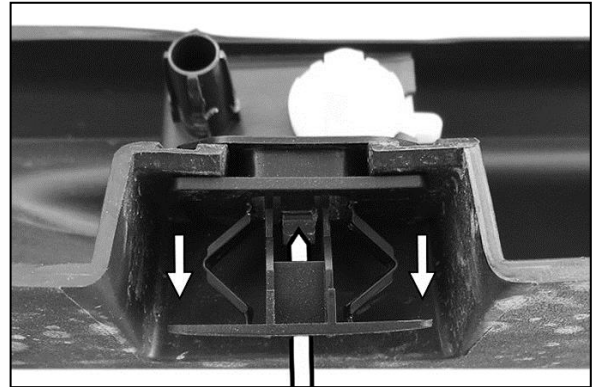

(Fig 2) Release both sides of clip and pull insert to release. Do not try to pull the clip out of the trim, only release clip as pictured

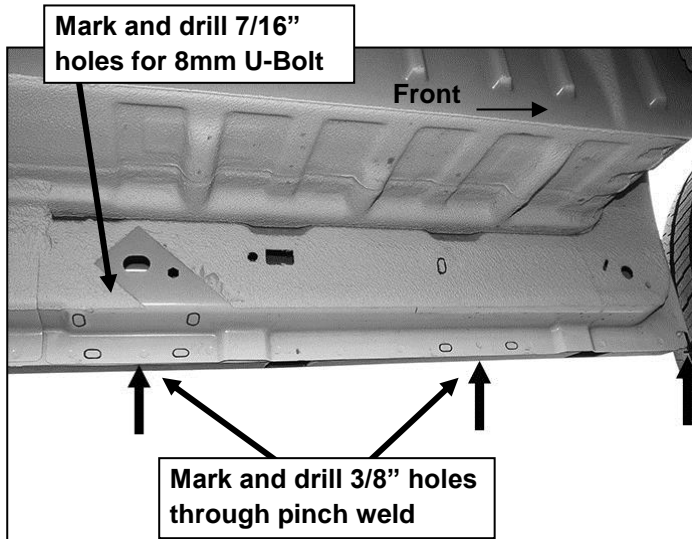

(Fig 3) Driver side front and rear mounting locations

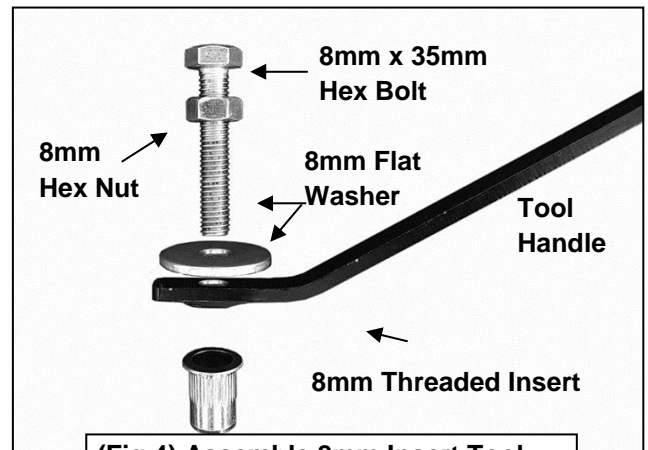

(Fig 4) Assemble 8mm Insert Tool

Hold 8mm Hex Bolt in position with wrench. Turn 8mm Hex Nut clockwise to "pull" insert



(Fig 5) Assemble 8mm Insert Tool

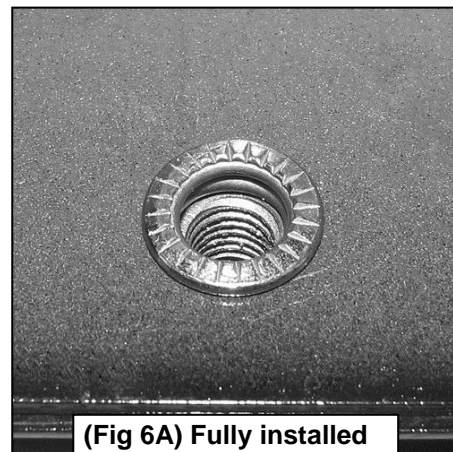

(Fig 6A) Fully installed Threaded Insert

Driver/Left Side Installation Pictured

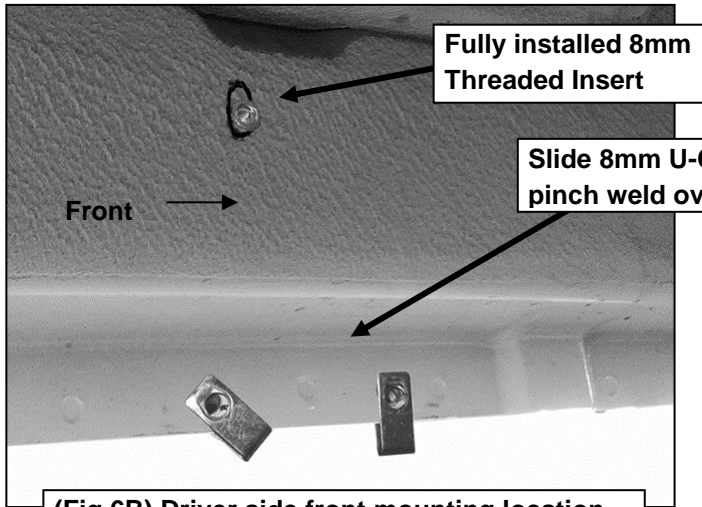

(Fig 6B) Driver side front mounting location



(Fig 7) Passenger side front mounting location

- (3) 8mm x 25mm Hex Bolts
- (3) 8mm Lock Washers
- (3) 8mm Flat Washers

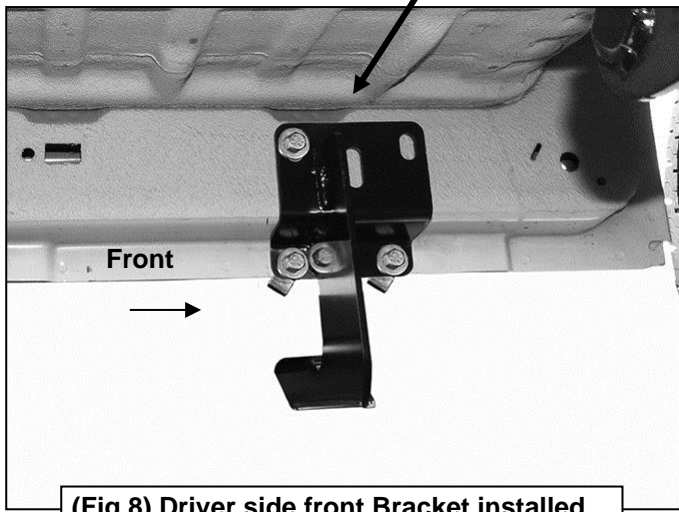

(Fig 8) Driver side front Bracket installed

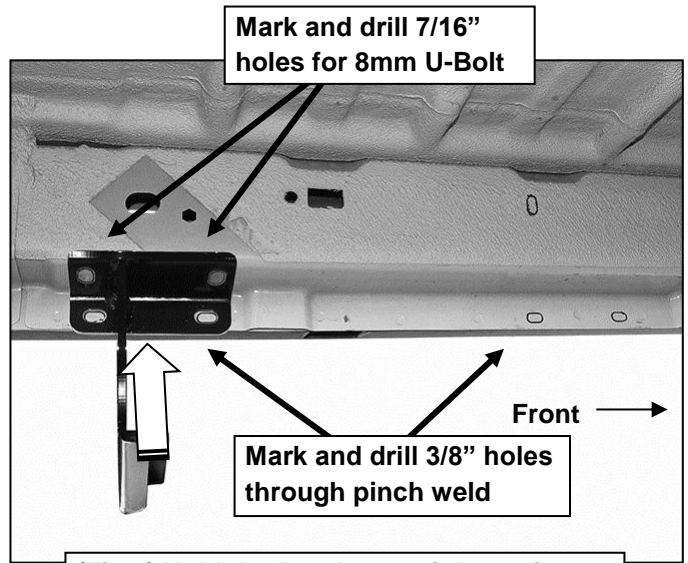

(Fig 9) Hold the Bracket up tight against the bottom of the body panel. Mark the (4) mounting location onto the body panel

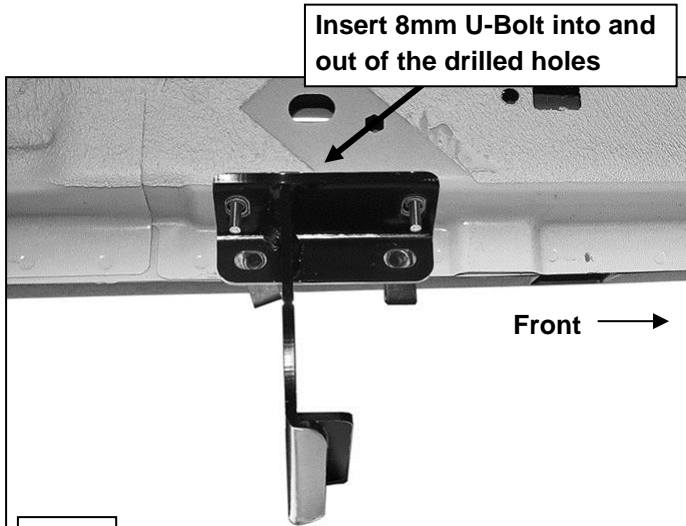
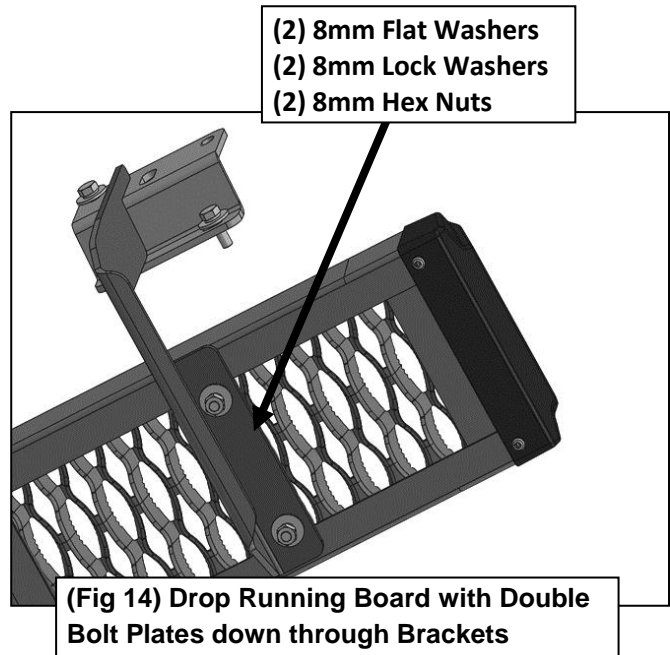
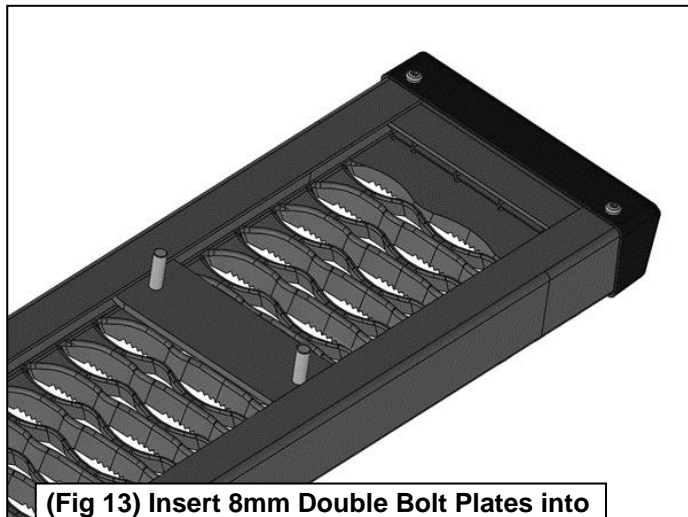
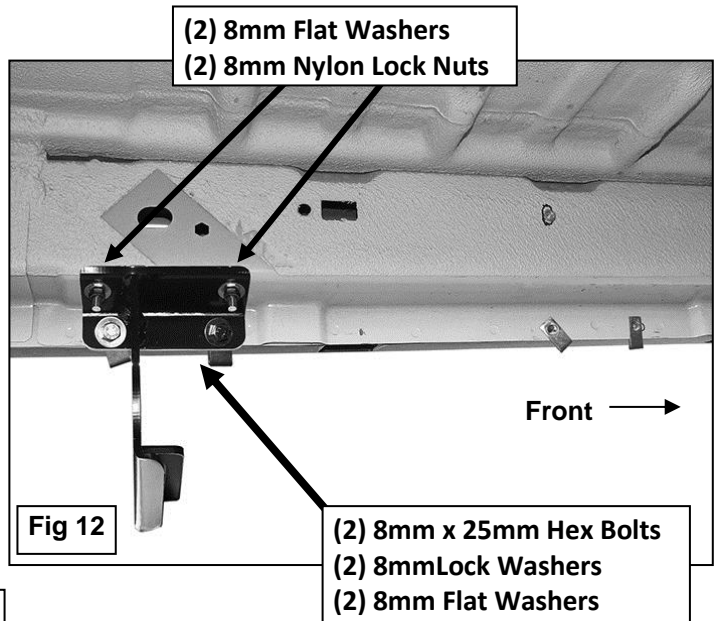
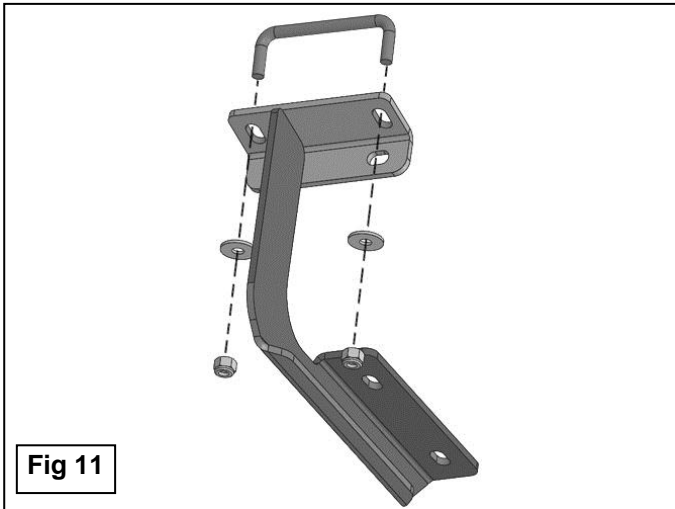

Fig 10

Driver/Left Side Installation Pictured



PARTS IDENTIFICATION GUIDE

Driver Side tube packed using "Green" color foam sheet. Passenger Side tube packed using "White" color foam sheet

No.	Parts Identification
1	Passenger / Right 'Rear' Bracket marked "PR"
2	Driver / Left 'Rear' Bracket marked "DR"
3	Passenger / Right 'Center' Bracket marked "PC"
4	Driver / Left 'Center' Bracket marked "DC"
5	Passenger / Right 'Front' Bracket marked "PF"
6	Driver / Left 'Front' Bracket marked "DF"

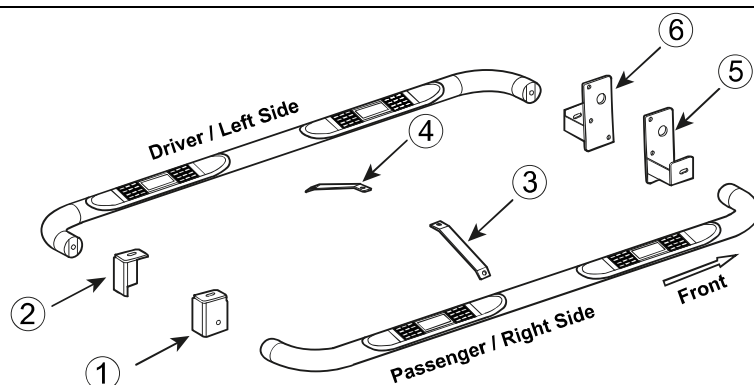
**Note:**

- This guide is to identify the parts and not a reference for part count.
- For part count, refer Parts List.
- Product / Bracket image is representative and actual design may vary.

PRODUCT CARE

- Periodically check the product to ensure all fasteners are tight and components are intact.
- Regular waxing is recommended to protect the finish of the product.
- **Use ONLY Non-Abrasive automotive wax.** Use of any soap, polish or wax that contains an abrasive is detrimental and can scratch the finish leading to corrosion.
- Aluminum polish may be used to polish small scratches and scuffs for **Stainless Steel finish.**
- Mild soap may be used to clean the product for both **Stainless Steel and Black finish.**

FAQ's**1. Hardware's are not of correct size.**

In GMC / Chevrolet truck model 2006 & up, customer needs to reuse the factory body bolts to install the bracket. If your vehicle is not GMC / Chevrolet 2006 & up, ensure that holes are not partially covered with any plastic grommet or rust? If it is, remove the plastic grommet & rust from the thread holes & re-try the installation.

2. Mounting Bracket are not getting Installed properly.

In some cases Illustration images shown in Installation manual may not be the exactly same as per actual vehicle images ,also if Driver / Passenger side mounting brackets are very identical in the design, suggest referring Parts Identification guide to avoid fitment issue.

3. Products are thumping / rattling after installation.

Ensure that all required mounting brackets / hardware's are installed & tighten correctly. Suggest using white lithium / regular grease between the metal to metal contact surfaces.

4. Side Bar is not aligning with vehicle / Step Pads are not aligning with vehicle doors.

Side bar may be interchanged or mounting brackets are not installed at the correct position in the vehicle. Refer Parts identification guide.

5. Missing / Excess Hardware.

Recheck hardware count as per the part list.

6. Product not installing properly.

Ensure make model year, cab length and bed size of your vehicle is listed in the application. All installation steps are followed correctly.

Check out these other TrailFX Products!!

www.TrailFX.com



BULL BAR



GRILLE GUARDS



BED RAILS



RUNNING BOARDS

Keystone Automotive Operations Inc. (KAO) warrants this product to be free of defects in material and workmanship at the time of purchase by the original retail consumer. KAO disclaims any other warranties, express or implied, including the warranty of fitness for a particular purpose or an intended use. If the product is found to be defective, KAO may replace or repair the product at our option, when the product is returned prepaid, with proof of purchase. Alteration to, improper installation, or misuse of this product voids the warranty. KAO's liability is limited to repair or replacement of products found to be defective, and specifically excludes liability for any incidental or consequential loss or damage.