

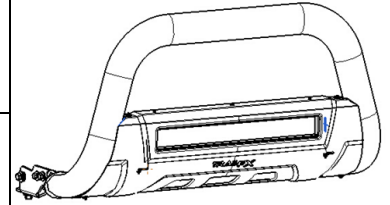

# 3.5" Oval Bull Bar

## Part No. B1603S/B



Fits: **2011-2016 Chevrolet Silverado/GMC Sierra 2500/3500**



ASSISTANCE IS RECOMMENDED.



60-180 min

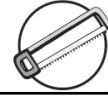

Cutting Required



Drilling Not Required



REMOVE CONTENTS FROM BOX. VERIFY ALL PARTS ARE PRESENT.



[support@trailfx.com](mailto:support@trailfx.com)



READ INSTRUCTIONS CAREFULLY BEFORE STARTING INSTALLATION.



1 866 638 4870

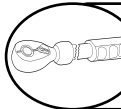

DO NOT OVER TORQUE. STANDARD OPERATING LOAD FOR TIGHTEN BODY MOUNT NUTS & BOLTS VARIES FROM **45** TO **65** FOOT POUND.



POLISHED STAINLESS STEEL – LIMITED LIFETIME  
POWDER COATED BLACK – 3 YEARS

### PARTS LIST:

Qty	Part Description	Qty	Part Description
1	3.5in Oval Bull Bar Assembly	4	12mm Plastic Retainers
1	Driver/left Frame Bracket	4	12mm x 32mm OD x 3mm Flat Washer
1	Passenger/Right Frame Bracket	4	12-1.75mm Nylon Lock Nut
1	Driver/left Bull Bar Mounting Bracket	8	10-1.5mm x 30mm Hex Bolt
1	Passenger/right Bull Bar Mounting Bracket	16	10mm x 27mm OD x 3mm Flat Washer
4	12-1.75mm x 35mm Bolt Plates	8	10-1.5mm Nylon Locknut

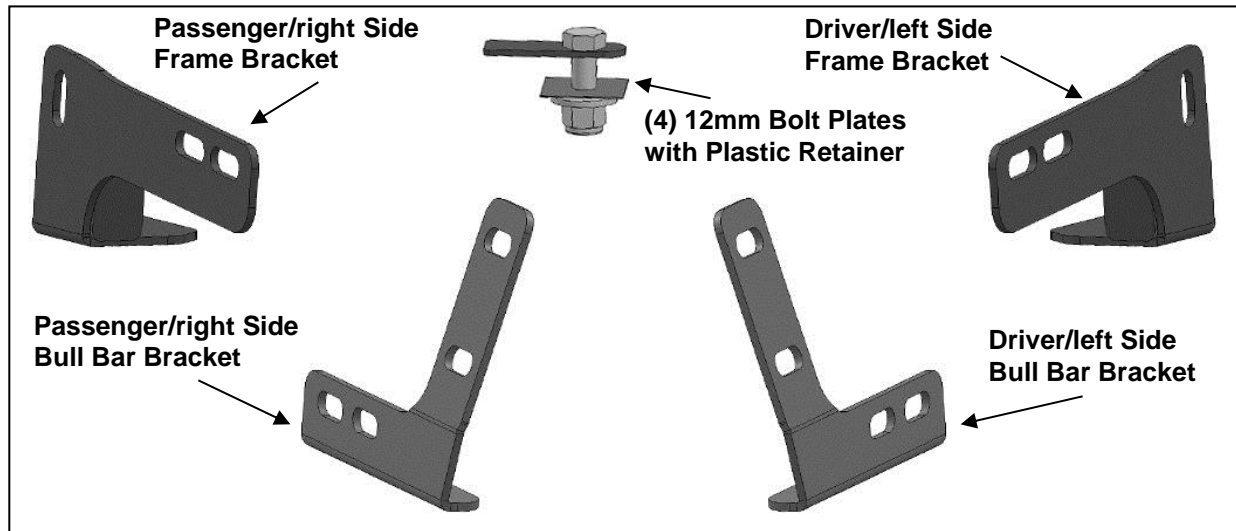

**INSTALLATION PROCEDURE:**

**CUTTING MAY BE REQUIRED. INSTALLATION MAY INTERFERE WITH BUMPER MOUNTED PARKING SENSORS. ASSISTANCE IS RECOMMENDED.**

**NOTE:** It may be necessary to remove/relocate front license plate and license plate bracket. It is not required, but strongly recommended. If local/state law requires a front license plate, license plate relocation kit is available.

- Starting at the driver side, remove the factory tow hook if equipped, (**Figures 1A & 1B**). **NOTE:** This Bull Bar is not compatible with the factory tow hooks and they cannot be reinstalled. **IMPORTANT:** On some model years, with and without tow hooks, the pocket in the plastic bumper may need to be trimmed or completely cut out, (**Figure 1A**). Use a sharp knife or hacksaw blade and carefully cut out the pocket to clear the Bull Bar Brackets. Only cut enough to clear the Brackets.

Remove the factory tow hook and hardware. Tow hook will not be reinstalled



Fig 1A

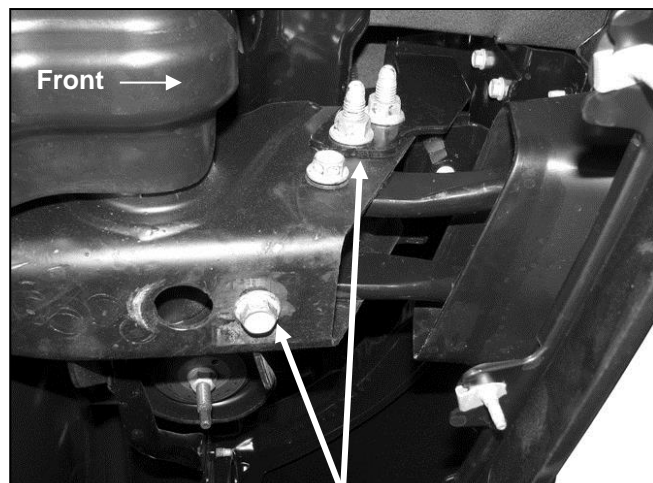
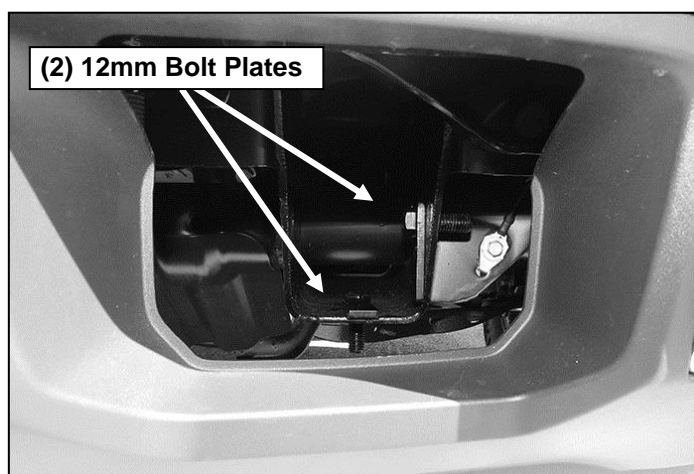

Fig 1B) Remove the tow hook and hardware, (Driver/left tow hook pictured from below bumper)

- Insert (1) 12mm Bolt Plate, (**Figure 3**), into the end of the frame channel, (**Figure 4**), and out through the hole in the bottom of the frame. Insert a second Bolt Plate into and out the hole in the outer side of the frame, (factory hole for tow hook bolt), (**Figures 4 & 5**). Thread 12mm Plastic Retainers onto the Bolt Plates to help hold them in place as needed. **NOTE:** Plastic Retainers are not required for installation and use is optional.



(Fig 3) 12mm Bolt Plate with hardware



(Fig 4) Driver/left side tow hook opening pictured

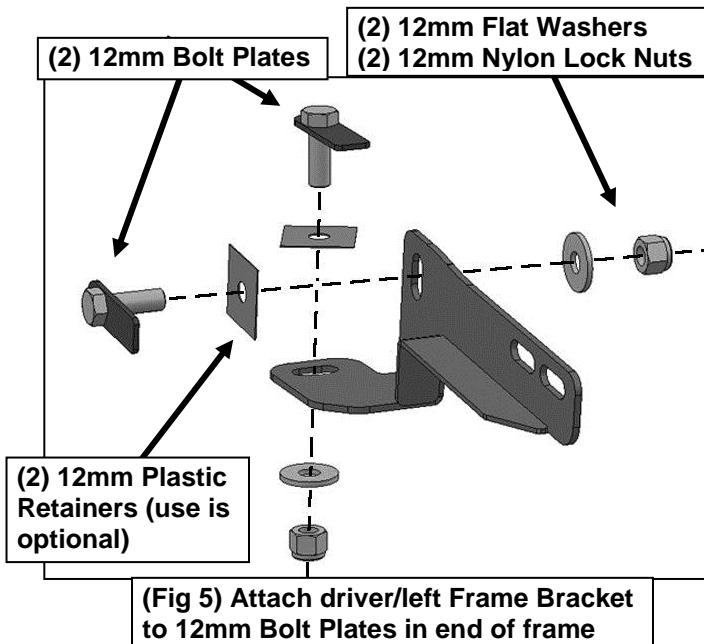

3. Select the driver side Frame Bracket, **(Figure 5)**. Position the Frame Bracket onto the outside of the frame channel and over the (2) Bolt Plates, **(Figure 6)**. Secure the Bracket to the frame and Bolt Plates with (2) 12mm Flat Washers and (2) 12mm Nylon Lock Nuts. Leave hardware loose at this time.

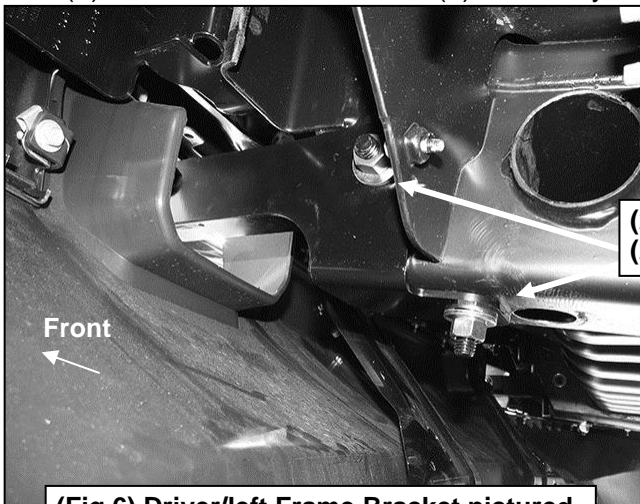

**(Fig 6) Driver/left Frame Bracket pictured**

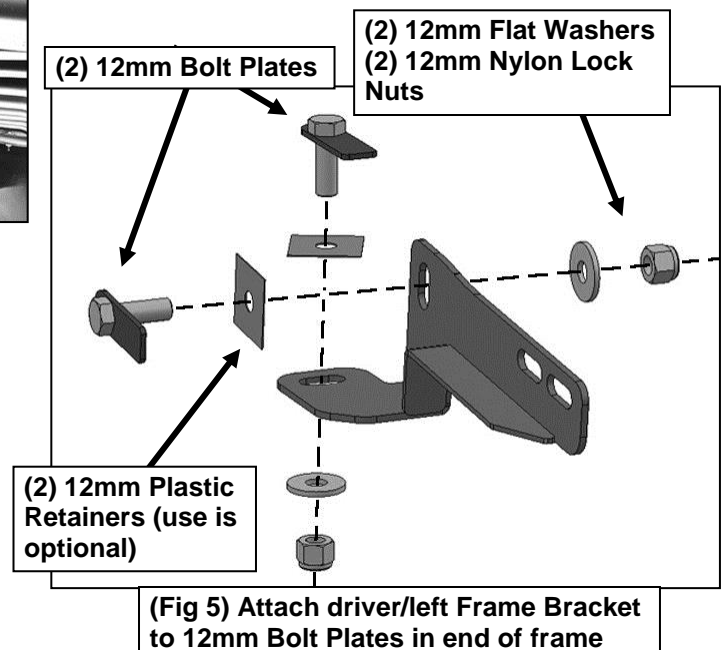

4. Next, select the driver side Bull Bar Mounting Bracket, **(Figure 7)**. Attach the Bull Bar Bracket to the inside of the Frame Bracket with the included (2) 10mm x 30mm Hex Bolts, (4) 10mm Flat Washers and (2) 10mm Nylon Lock Nuts, **(Figure 7)**. Leave hardware loose at this time. **NOTE:** On some models, it may be possible or simpler to bolt the Frame and Mounting Brackets together first and install as one piece.

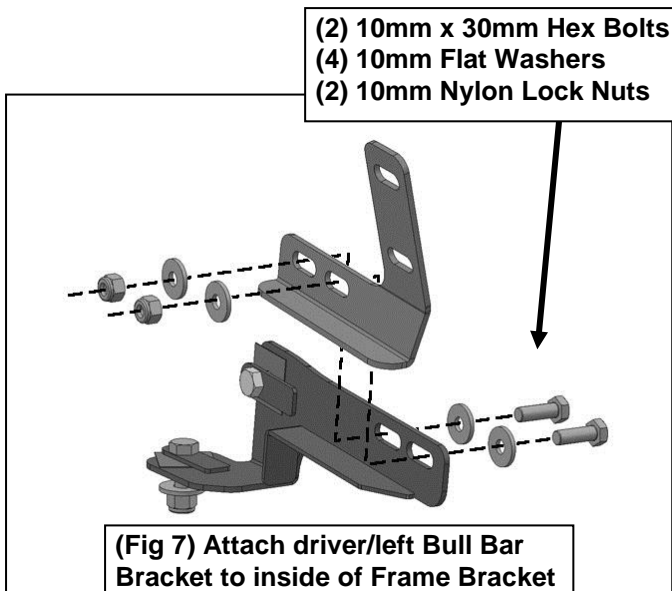

5. Starting at the bottom of the frame, tighten the lower 12mm Frame Bracket mounting hardware first then move to the side of the frame. Fully tighten Frame Bracket to 12mm Bolt Plate hardware only at this time. Do not tighten the 10mm Bull Bar Bracket hardware.
6. Repeat **Steps 1—5** for passenger side Frame and Mounting Bracket installation.
7. With assistance, position the Bull Bar assembly up to the inside of the Mounting Brackets. Attach the Bull Bar to the Brackets with the included (4) 10mm x 30mm Hex Bolts, (8) 10mm Flat Washers and (4) 10mm Nylon Lock Nuts, (**Figure 8**). Do not fully tighten hardware at this time.

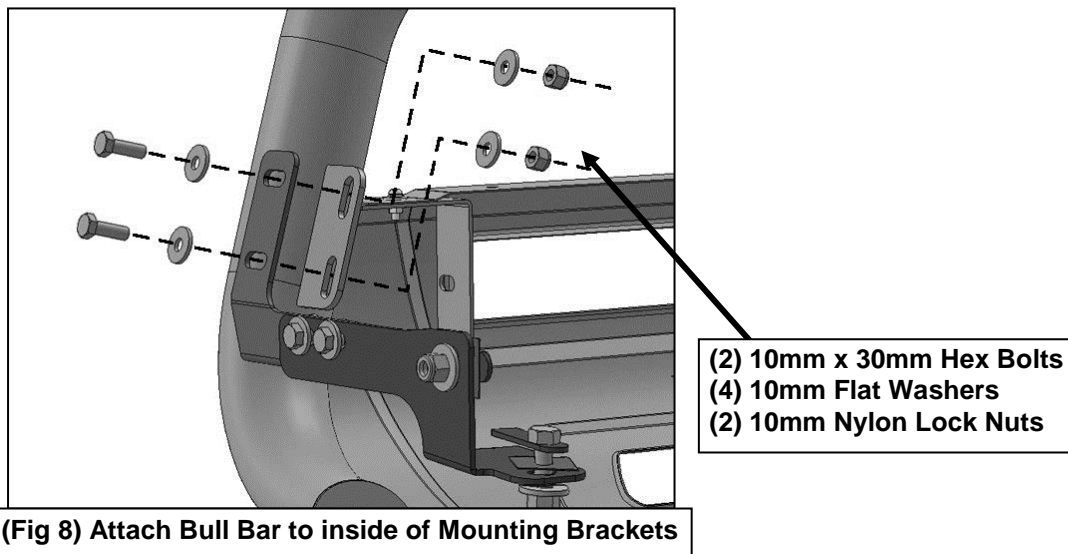

8. Level and adjust the Bull Bar and fully tighten all remaining hardware.
9. Do periodic inspections to the installation to make sure that all hardware is secure and tight.

**PRODUCT CARE**

- Periodically check the product to ensure all fasteners are tight and components are intact.
- Regular waxing is recommended to protect the finish of the product.
- **Use ONLY Non-Abrasive automotive wax.** Use of any soap, polish or wax that contains an abrasive is detrimental and can scratch the finish leading to corrosion.
- Aluminum polish may be used to polish small scratches and scuffs for **Stainless Steel finish.**
- Mild soap may be used to clean the product for both **Stainless Steel and Black finish.**

**FAQ's****1. Hardware's are not of correct size.**

*In GMC / Chevrolet truck model 2006 & up, customer needs to reuse the factory body bolts to install the bracket. If your vehicle is not GMC / Chevrolet 2006 & up, ensure that holes are not partially covered with any plastic grommet or rust? If it is, remove the plastic grommet & rust from the thread holes & re-try the installation.*

**2. Mounting Bracket are not getting Installed properly.**

*In some cases Illustration images shown in Installation manual may not be the exactly same as per actual vehicle images ,also if Driver / Passenger side mounting brackets are very identical in the design, suggest referring Parts Identification guide to avoid fitment issue.*

**3. Products are thumping / rattling after installation.**

*Ensure that all required mounting brackets / hardware's are installed & tighten correctly. Suggest using white lithium / regular grease between the metal to metal contact surfaces.*

**4. Side Bar is not aligning with vehicle / Step Pads are not aligning with vehicle doors.**

*Side bar may be interchanged or mounting brackets are not installed at the correct position in the vehicle. Refer Parts identification guide.*

**5. Missing / Excess Hardware.**

*Recheck hardware count as per the part list.*

**6. Product not installing properly.**

*Ensure make model year, cab length and bed size of your vehicle is listed in the application. All installation steps are followed correctly.*

**Check out these other TrailFX Products!!**

**www.TrailFX.com**



**BULL BAR**



**GRILLE GUARDS**



**BED RAILS**



**RUNNING BOARDS**

*Keystone Automotive Operations Inc. (KAO) warrants this product to be free of defects in material and workmanship at the time of purchase by the original retail consumer. KAO disclaims any other warranties, express or implied, including the warranty of fitness for a particular purpose or an intended use. If the product is found to be defective, KAO may replace or repair the product at our option, when the product is returned prepaid, with proof of purchase. Alteration to, improper installation, or misuse of this product voids the warranty. KAO's liability is limited to repair or replacement of products found to be defective, and specifically excludes liability for any incidental or consequential loss or damage.*