

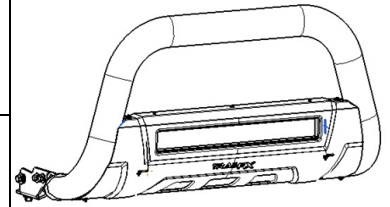

3.5" Oval Bull Bar

Part No.B1605S/B



Fits: 2009-Current

Dodge Ram 1500



Excl. Rebel Trim



REMOVE CONTENTS FROM BOX. VERIFY ALL PARTS ARE PRESENT.



READ INSTRUCTIONS CAREFULLY BEFORE STARTING INSTALLATION.

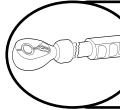

DO NOT OVER TORQUE. STANDARD OPERATING LOAD FOR TIGHTEN BODY MOUNT NUTS & BOLTS VARIES FROM 45 TO 65 FOOT POUND.



60-180 min

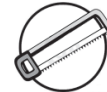

Cutting Required



Drilling Not Required



support@trailfx.com



1 866 638 4870



POLISHED STAINLESS STEEL – LIMITED LIFETIME
POWDER COATED BLACK – 3 YEARS

PARTS LIST:

Qty	Part Description	Qty	Part Description
1	Bull Bar	2	10-1.5mm x 35mm Hex Bolts
2	Tube Brackets (Bull Bar) passenger or driver side	2	10mm Lock Washers
1	Driver/Left Upper Bracket (models w/o tow hooks only)	4	10mm x 27mm OD x 3mm Flat Washers
1	Passenger/Right Upper Bracket (models w/o tow hooks only)	2	10-1.5mm Hex Nuts
1	Driver/Left Frame Mounting Bracket	4	8-1.25mm x 35mm Hex Bolts
1	Passenger/Right Frame Mounting Bracket	4	8mm x 22mm OD x 2mm Flat Washers
1	Driver/Left Support Bracket	4	8mm Lock Washers
1	Passenger/Right Support Bracket	2	5-.8mm x 20mm Button Head Allen Bolt
2	12-1.5mm x 30mm Special Fine Thread Hex Bolt (for models w/o tow hooks only)	4	5mm x 10mm OD x 1mm Flat Washers
4	12-1.75mm x 35mm Hex Bolts	2	5mm Nylon Lock Nuts
14	12mm x 32mm OD x 3mm Flat Washers	1	Wrench (Allen bolt)
10	12mm Lock Washers		
8	12-1.75mm Hex Nuts		

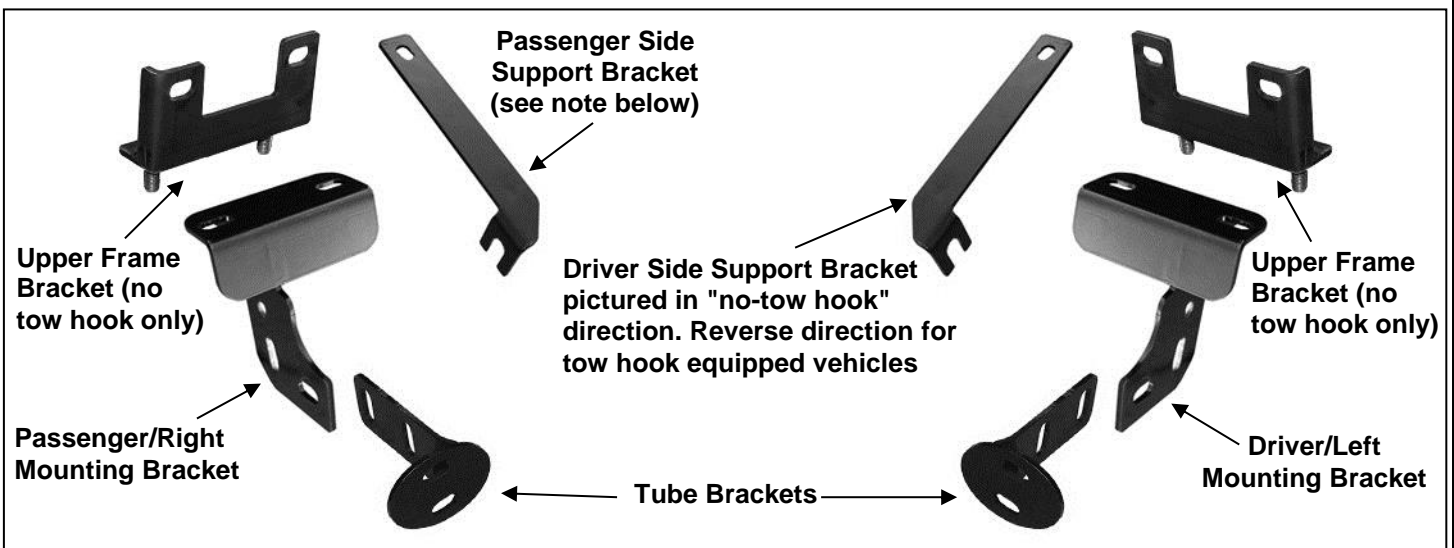

INSTALLATION PROCEDURE:

REMOVE CONTENTS FROM BOX. VERIFY ALL PARTS ARE PRESENT. READ INSTRUCTIONS CAREFULLY BEFORE STARTING INSTALLATION. CUTTING IS REQUIRED. ASSISTANCE IS RECOMMENDED. INSTALLATION MAY INTERFERE WITH FRONT BUMPER MOUNTED SENSORS. NOT RECOMMENDED FOR VEHICLES WITH "ACTIVE" LASER GUIDED CRUISE CONTROL SYSTEMS.

1. Start installation under the front bumper and carefully remove the plastic splash guard. NOTE: Depending on the model of truck, the splash guard may be attached to the bottom of the truck with hex bolts and several two-piece plastic push-in clips, (Figure 1A). Remove all hex bolts then locate the clips behind the bumper cover. Pry up on the center pin of the clip with a small flat blade screwdriver and remove the entire clip, (Figure 1B). Pay close attention to the type and location of all factory hardware for reinstallation. IMPORTANT: The splash guard may also be attached at the ends of the bumper cover with rivets. Use wire cutters to remove the rivets. Move the splash guard to a clean stable work area.

Pry up the center pin to remove the complete fastener

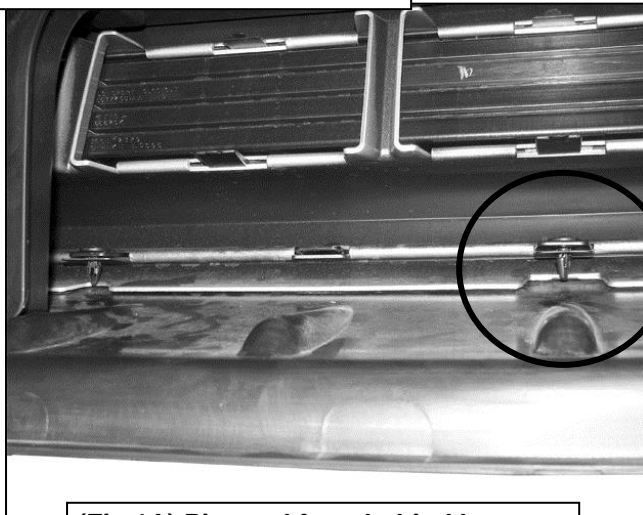

(Fig 1A) Pictured from behind bumper

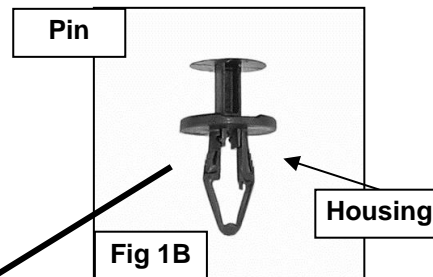

2. Next, determine if the truck is equipped with tow hooks.

For models without tow hooks:

- a. Remove the (2) hex nuts from the two lower bumper bolts, (Figure 2).

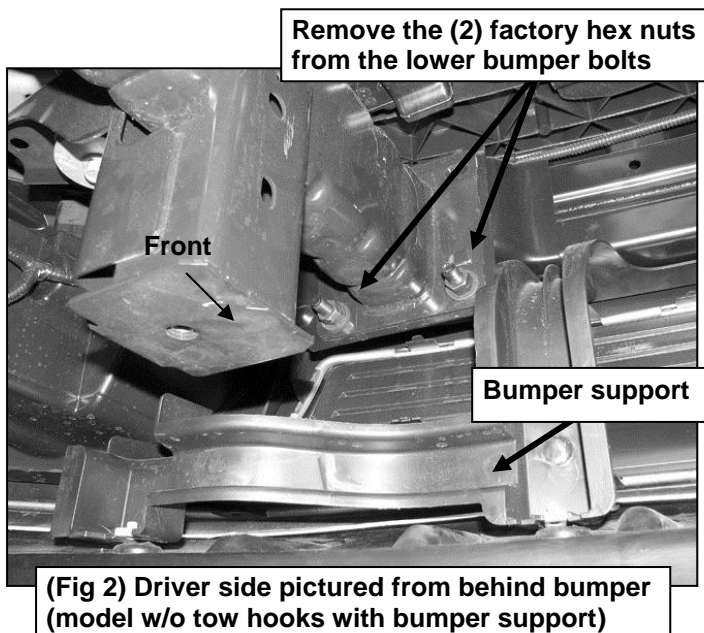

- b. Select the driver/left Upper Bracket, (models w/o tow hooks only), and the driver/left Frame Bracket, (Figure 3). Attach the Frame Bracket to the studs in the bottom of the Upper Bracket with (2) 12mm Flat Washers, (2) 12mm Lock Washers and (2) 12mm Hex Nuts, (Figure 4). Do not tighten at this time.

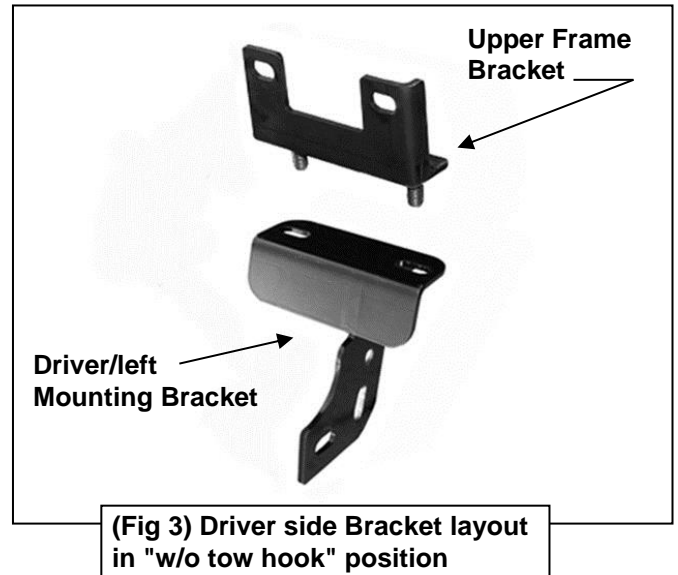
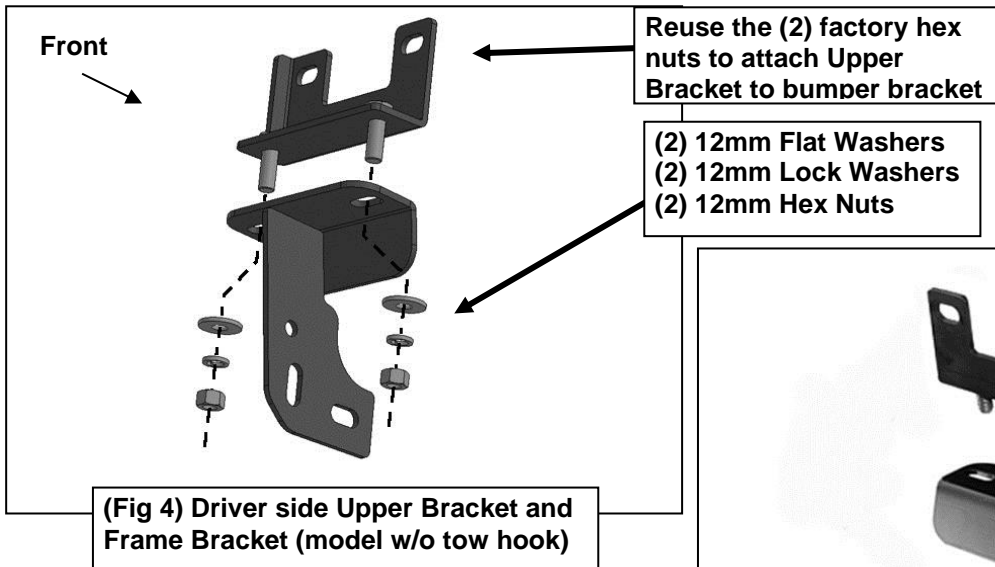

- c. Reuse the factory hex nuts to attach the Bracket assembly to the bumper bolts. Do not fully tighten the hardware, (Figure 7).

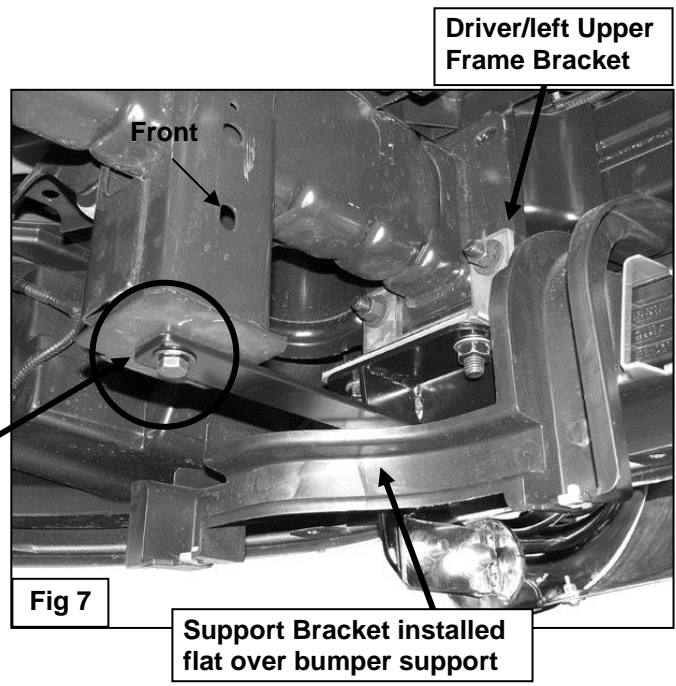

IMPORTANT: On models without tow hooks, use only the supplied 12-1.5mm x 30mm Fine Thread Hex Bolt, 12mm Flat Washer, 12mm Lock Washer

NOTE: On some vehicles, it may be easier to assemble the two-piece bracket on the vehicle. Install the Upper Bracket first, then attach the Frame Bracket to the bottom as previously described.

- d. Select the driver side Lower Support Bracket, (Figure 5). Attach the bent end of the Support Bracket to the inside of the top hole in the Mounting Bracket with the included (1) 10mm x 35mm Hex Bolt, (2) 10mm Flat Washers, (1) 10mm Lock Washer and (1) 10mm Hex Nut, (Figure 6). **NOTE:** On models without tow hooks, Support Bracket can be installed in either direction, (Figures 5, 6—9).

IMPORTANT: On models without tow hooks, use only the supplied
 12-1.5mm x 30mm Fine Thread Hex Bolt
 12mm Lock Washer
 12mm Flat Washer

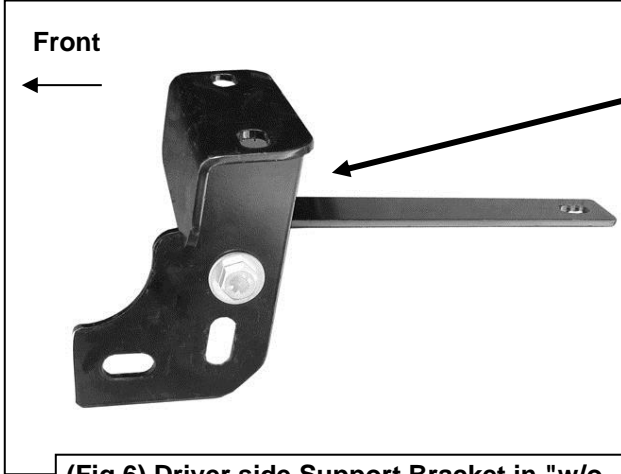
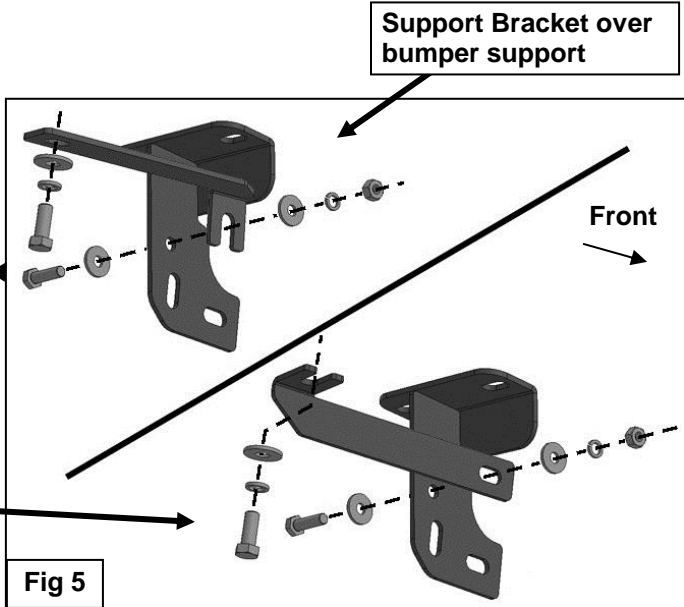

- (1) 10mm x 35mm Hex Bolt
- (2) 10mm Flat Washers
- (1) 10mm Lock Washer
- (1) 10mm Hex Nut

Driver/left Upper Frame Bracket

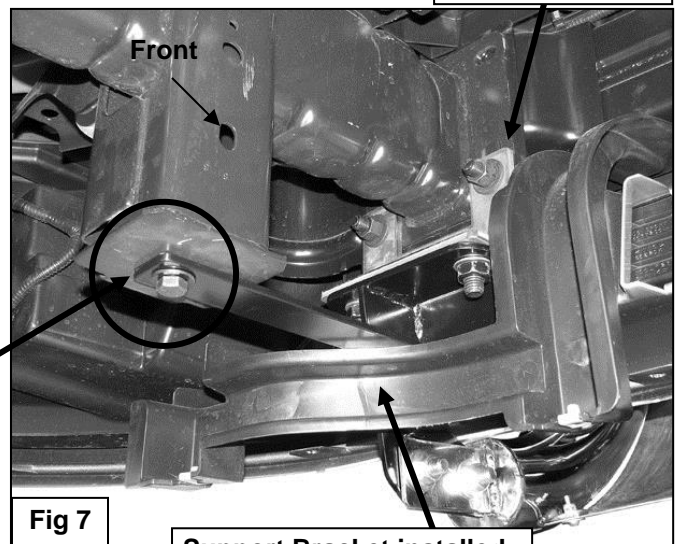

(Fig 6) Driver side Support Bracket in "w/o tow hook-with bumper support" position

IMPORTANT: On models without tow hooks, use only the supplied
 12-1.5mm x 30mm Fine Thread Hex Bolt
 12mm Flat Washer
 12mm Lock Washer

Support Bracket installed flat over bumper support

Driver side Support Bracket in "w/o tow hook-w/o bumper support" position

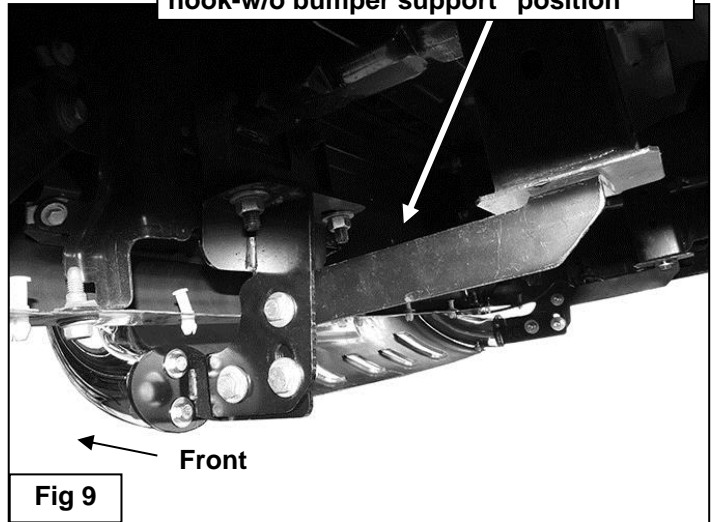
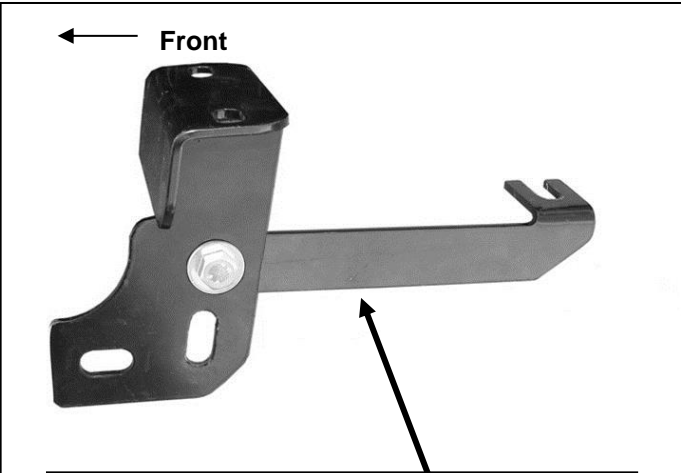

(Fig 8) Driver side Support Bracket in "w/o tow hook-w/o bumper support" position

- e. Attach the inner end of the Support Bracket to the bottom of the frame with (1) 12-1.5mm x 30mm **Special Fine Thread Hex Bolt**, (1) 12mm Lock Washer and (1) 12mm Flat Washer, (**Figure 5**). **IMPORTANT:** The hole in the bottom of the frame is **fine thread**. Only use the 12-1.5mm x 30mm Fine Thread Hex Bolt provided in the hardware kit. Do not tighten all hardware at this time.

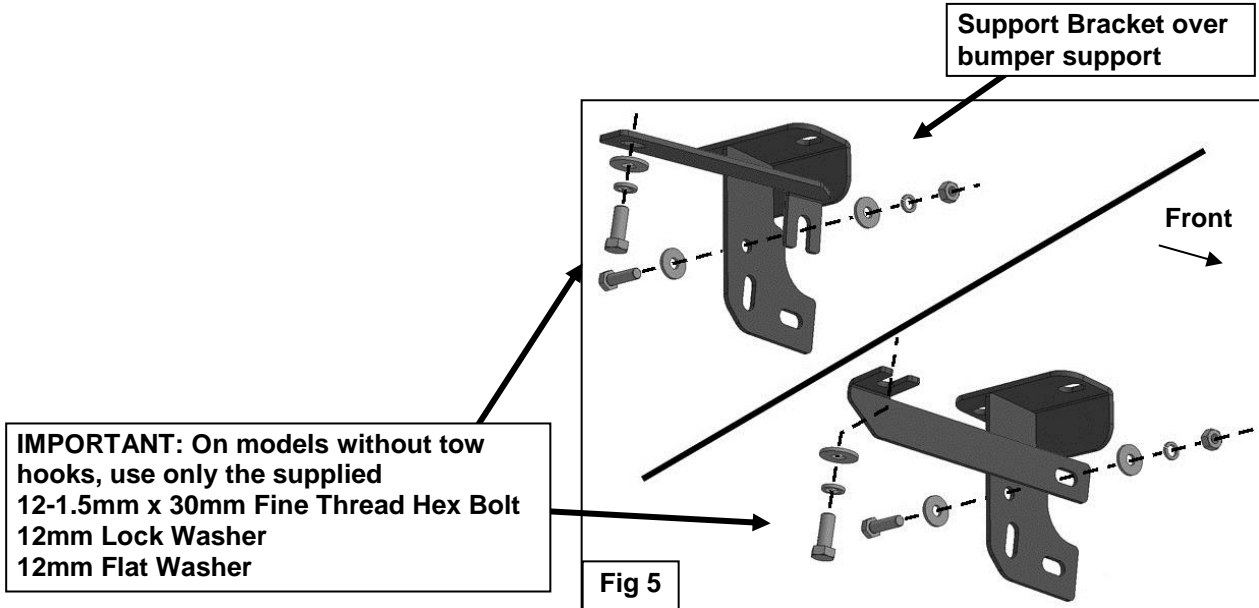

For models with tow hooks:

- a. Remove the (2) hex nuts attaching the front of the tow hook to the bottom of the bumper bracket, (**Figure 10**).

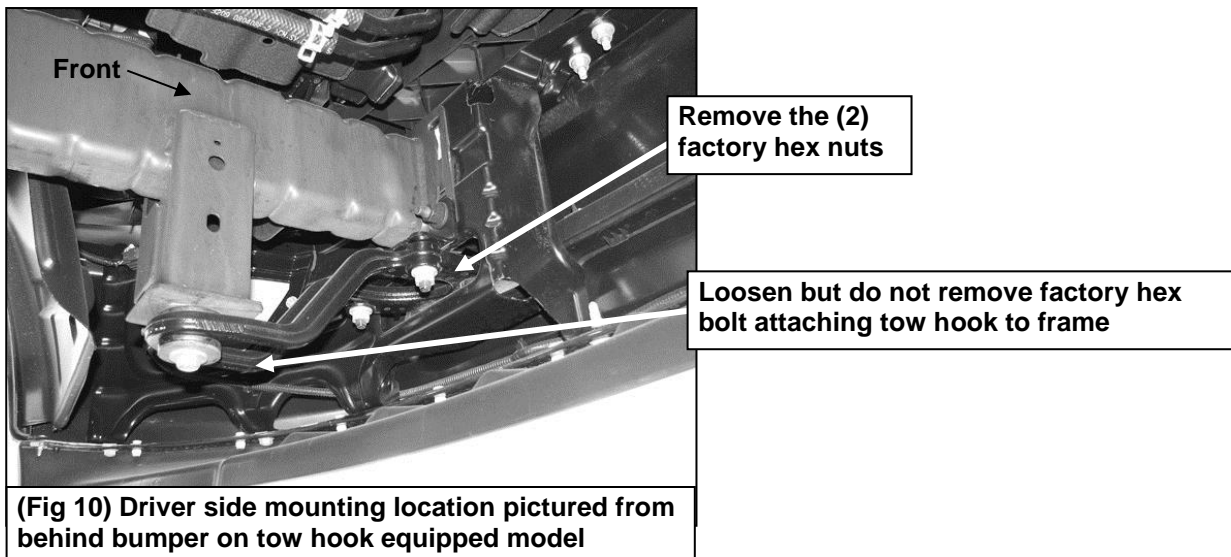

- b. Select the driver/left Frame Bracket, (**Figure 11**). Attach the Bracket to the bottom of the tow hook with the (2) factory hex nuts. Do not tighten hardware at this time.

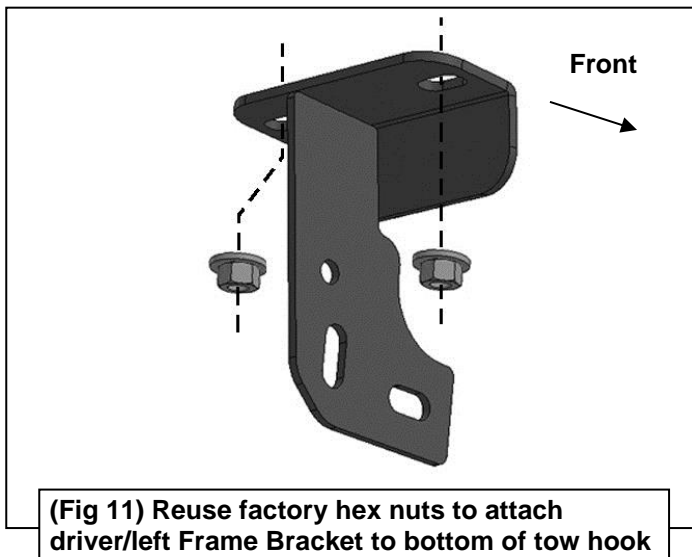

(Fig 11) Reuse factory hex nuts to attach driver/left Frame Bracket to bottom of tow hook

- c. Loosen but do not remove the rear tow hook bolt, **(Figure 10)**. Slide the inner bent end of the driver side Support Bracket between the bolt and the tow hook or replace with the included (1) 12-1.5mm x 30mm **Special Fine Thread** Hex Bolt, (1) 12mm Lock Washer and (1) 12mm Flat Washer, **(Figure 12)**. Do not tighten hardware at this time.

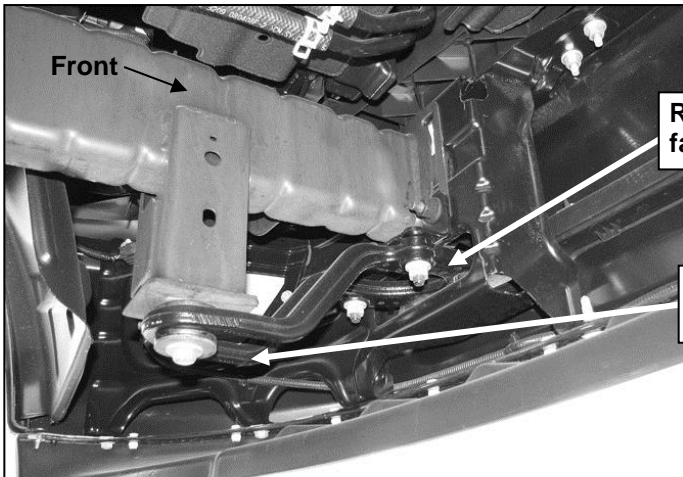

(Fig 10) Driver side mounting location pictured from behind bumper on tow hook equipped model

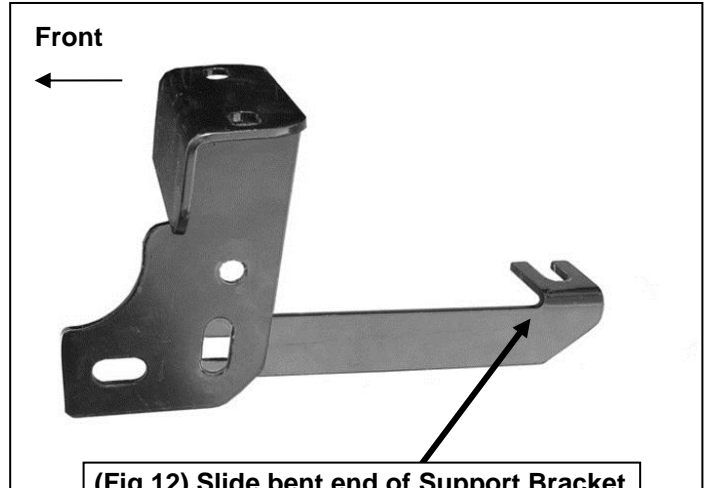

(Fig 12) Slide bent end of Support Bracket under head of factory hex bolt attaching tow hook to frame (Fig 10). Do not attach forward end of Support Bracket.

- d. Line up the flat forward end of the Support Bracket with the inside of the Mounting Bracket. The Support Bracket will attach to the lower rear hole in the Bracket. Do not attach at this time.

3. Repeat the appropriate **Step 2** for the passenger side Mounting Bracket installation.
4. Next, select (1) Tube Mounting Bracket, **(Figure 13)**. Attach the Tube Bracket to the end of the Bull Bar with (2) 8mm x 35mm Hex Bolts, (2) 8mm Lock Washers and (2) 8mm Flat Washers. Leave hardware loose at this time. Repeat this **Step** to install the passenger side Tube Bracket.

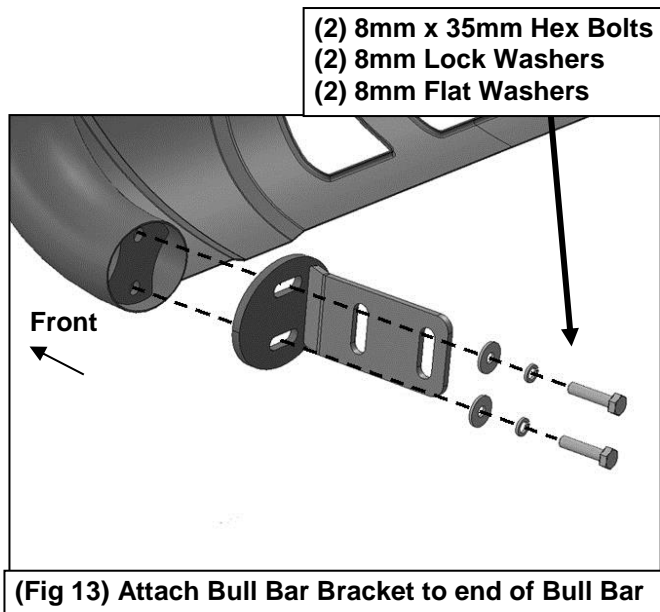

(Fig 13) Attach Bull Bar Bracket to end of Bull Bar

- With assistance, position the Bull Bar with Tube Brackets up to the inside of the Frame Brackets. Use the included (4) 12-1.75mm x 35mm Hex Bolts, (8) 12mm Flat Washers, (4) 12mm Lock Washers and (4) 12mm Hex Nuts to attach the Tube Brackets to the Mounting Brackets, **(Figures 14)**. **NOTE:** On vehicles with tow hooks, insert the 12mm rear Hex Bolt through the rear hole in the Mounting Bracket, the Tube Bracket in the middle and out through the flat end of the Support Bracket. Do not tighten hardware at this time.

Models w/o tow hooks:
 (2) 12mm x 35mm Hex Bolts
 (4) 12mm Flat Washers
 (2) 12mm Lock Washers
 (2) 12mm Hex Nuts

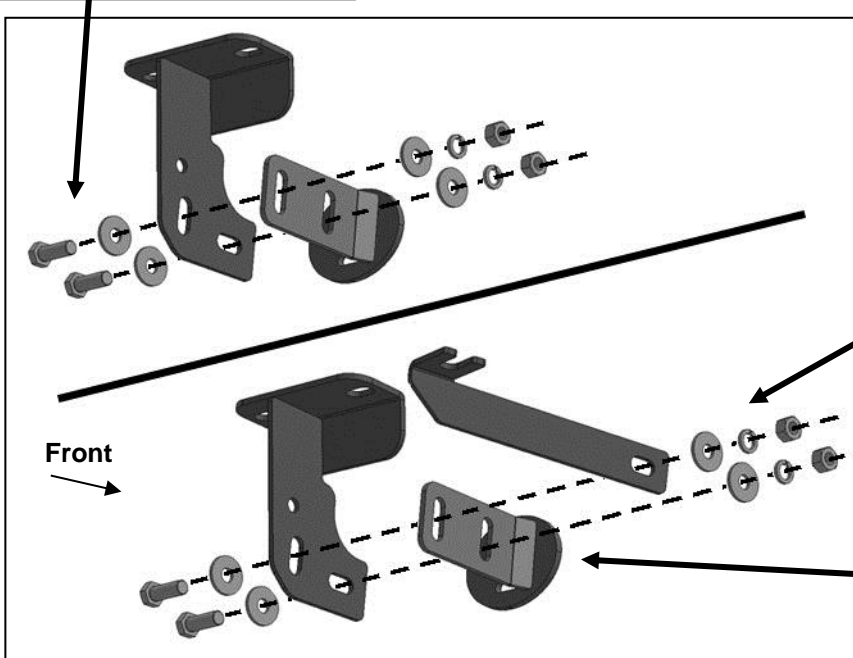

Models with tow hooks:
 (2) 12mm x 35mm Hex Bolts
 (4) 12mm Flat Washers
 (2) 12mm Lock Washers
 (2) 12mm Hex Nuts

Models with tow hooks, line up Bull Bar Bracket between Frame Bracket and Support Bracket

(Fig 14) Attach Bull Bar with Brackets to Frame Brackets

- Stand back from the vehicle and check to see that the Bull Bar is centered and level on the vehicle and adjust as necessary. Tighten only the hardware securing the Upper and Frame Mounting Brackets to the vehicle first. Next tighten only the (4) 8mm Hex Bolts securing the Tube Brackets to the Bull Bar as described in **Step 4**. Do not tighten the 12mm hardware attaching the Tube Brackets to the Frame Mounting Brackets. Remove the Bull Bar with Tube Brackets attached.
- Hold the splash guard up to the bumper cover and align it with the mounting points, **(Figure 15)**. Mark the location of the Mounting Brackets onto the back of the splash guard, **(Figures 15—17)**. Cut an approximately 1" wide by 4" long slot in the splash guard, **(Figure 17)**. **NOTE:** The size of the slot is an estimate only and may vary due to different factory designs for the splash guards and front bumper covers. Also, additional cutting may be required to clear the Support Bracket on vehicles equipped with tow hooks. **IMPORTANT:** To avoid weakening the splash guard, do not cut the slot any larger than necessary. Do not cut through the front or back edges of the cover, **(Figure 17)**. Make several small cuts first and check the fit often for a clean installation.

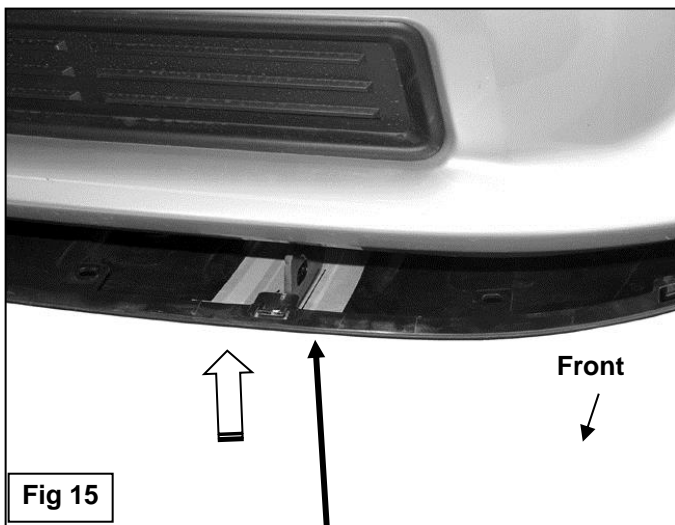

Fig 15

Hold the splash guard up to the bottom of the brackets and mark location for cutting to clear brackets. Cut only what is needed to insert bracket through the splash guard.

Installation pictured without the splash guard for instruction purposes only

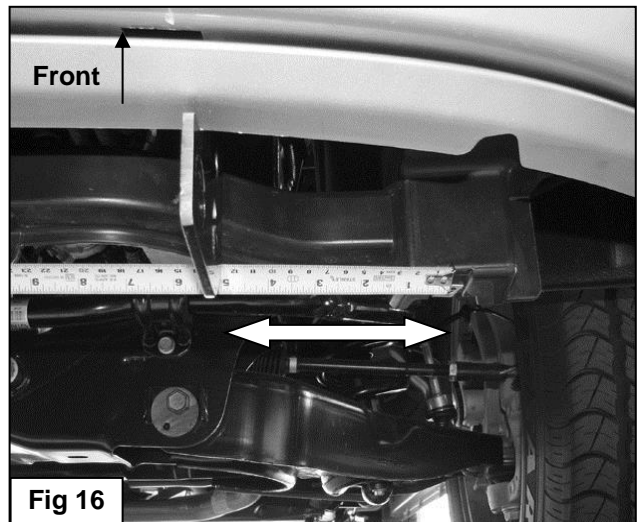
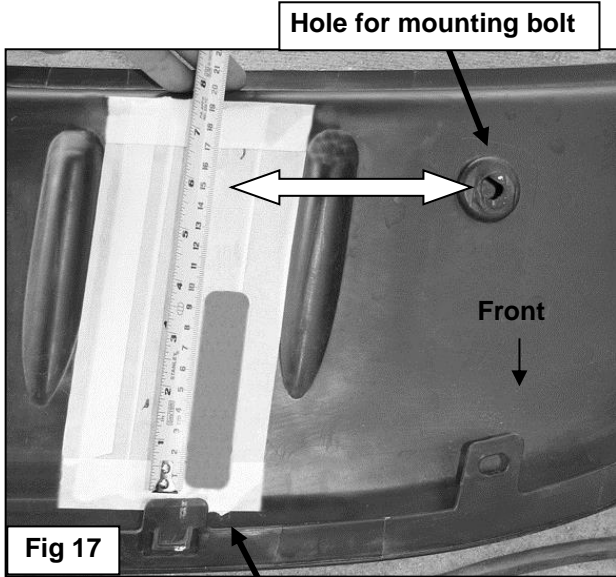

Fig 16



Measure the distance from the mounting point for the splash guard to the bracket on the driver and passenger side. Use this measurement as a reference point to check location before cutting the 1" wide x 4" long slot

Cut only what is needed to insert bracket through the splash guard. Do not cut through the front edge of the splash guard

8. Reinstall the splash guard using the factory hardware. Use the included (2) 5mm x 15mm Allen Bolts, (4) 5mm Flat Washers and (2) 5mm Lock Nuts at the ends of the splash guard if required, (Figure 18).

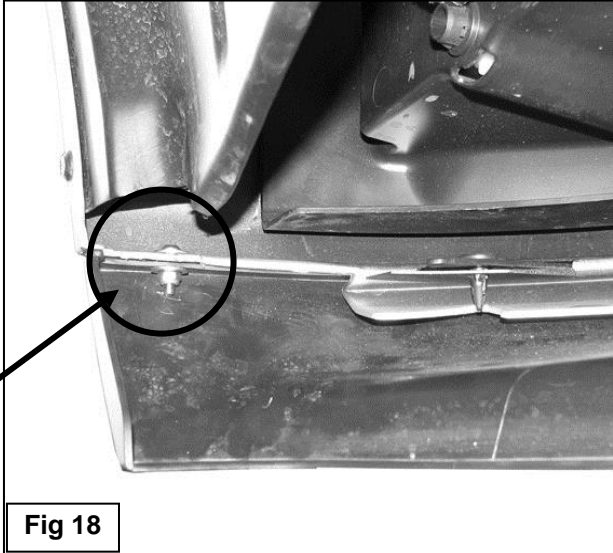

If required, replace the rivet at the corner of the splash guard with the supplied:
 5mm x 15mm Button Head Allen Bolt
 (2) 5mm Flat Washers
 5mm Nylon Lock Nut

9. Reinstall the Bull Bar described in Step 5, (Figure 14).

Models w/o tow hooks:
 (2) 12mm x 35mm Hex Bolts
 (4) 12mm Flat Washers
 (2) 12mm Lock Washers

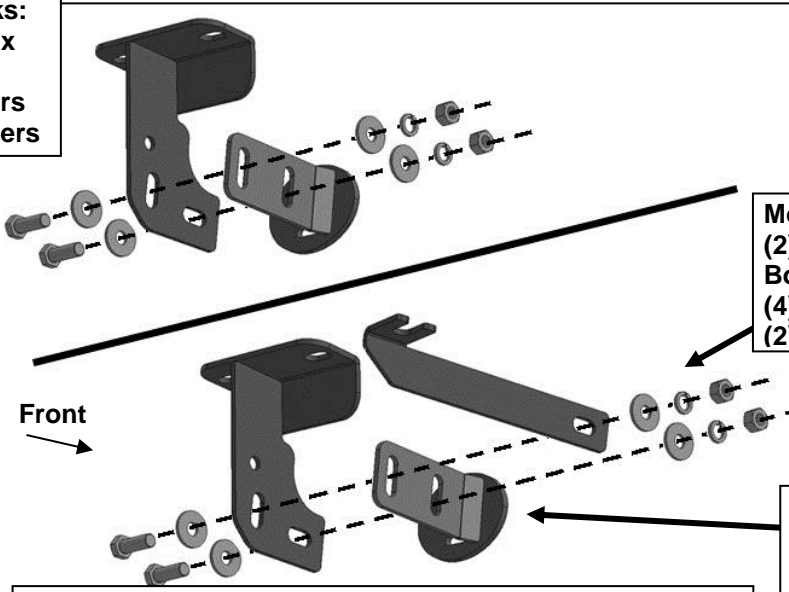

Models with tow hooks:
 (2) 12mm x 35mm Hex Bolts
 (4) 12mm Flat Washers
 (2) 12mm Lock Washers

Models with tow hooks, line up Bull Bar Bracket between Frame Bracket and Support Bracket

(Fig 14) Attach Bull Bar with Brackets to Frame Brackets

10. Level and adjust the Bull Bar and tighten all hardware.

PRODUCT CARE

- Periodically check the product to ensure all fasteners are tight and components are intact.
- Regular waxing is recommended to protect the finish of the product.
- **Use ONLY Non-Abrasive automotive wax.** Use of any soap, polish or wax that contains an abrasive is detrimental and can scratch the finish leading to corrosion.
- Aluminum polish may be used to polish small scratches and scuffs for **Stainless Steel finish.**
- Mild soap may be used to clean the product for both **Stainless Steel and Black finish.**

FAQ's**1. Hardware's are not of correct size.**

In GMC / Chevrolet truck model 2006 & up, customer needs to reuse the factory body bolts to install the bracket. If your vehicle is not GMC / Chevrolet 2006 & up, ensure that holes are not partially covered with any plastic grommet or rust? If it is, remove the plastic grommet & rust from the thread holes & re-try the installation.

2. Mounting Bracket are not getting Installed properly.

In some cases Illustration images shown in Installation manual may not be the exactly same as per actual vehicle images ,also if Driver / Passenger side mounting brackets are very identical in the design, suggest referring Parts Identification guide to avoid fitment issue.

3. Products are thumping / rattling after installation.

Ensure that all required mounting brackets / hardware's are installed & tighten correctly. Suggest using white lithium / regular grease between the metal to metal contact surfaces.

4. Side Bar is not aligning with vehicle / Step Pads are not aligning with vehicle doors.

Side bar may be interchanged or mounting brackets are not installed at the correct position in the vehicle. Refer Parts identification guide.

5. Missing / Excess Hardware.

Recheck hardware count as per the part list.

6. Product not installing properly.

Ensure make model year, cab length and bed size of your vehicle is listed in the application. All installation steps are followed correctly.

Check out these other TrailFX Products!!

www.TrailFX.com



SIDE BAR

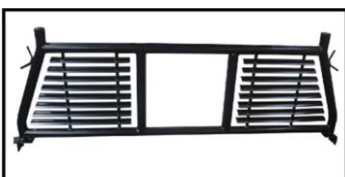

HEADACHE RACKS

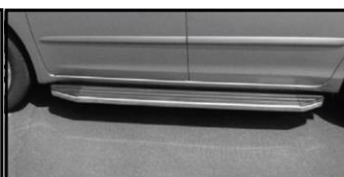

RUNNING BOARDS



ROCKER GUARDS

Keystone Automotive Operations Inc. (KAO) warrants this product to be free of defects in material and workmanship at the time of purchase by the original retail consumer. KAO disclaims any other warranties, express or implied, including the warranty of fitness for a particular purpose or an intended use. If the product is found to be defective, KAO may replace or repair the product at our option, when the product is returned prepaid, with proof of purchase. Alteration to, improper installation, or misuse of this product voids the warranty. KAO's liability is limited to repair or replacement of products found to be defective, and specifically excludes liability for any incidental or consequential loss or damage.