

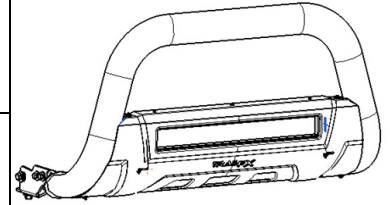

3.5" Oval Bull Bar

Part No. B1606S/B



Fits: 2010-Current

Dodge Ram 2500/3500



Can be installed on Ecoboost equipped vehicles but is not recommended.



REMOVE CONTENTS FROM BOX. VERIFY ALL PARTS ARE PRESENT.



READ INSTRUCTIONS CAREFULLY BEFORE STARTING INSTALLATION.

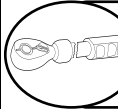

DO NOT OVER TORQUE. STANDARD OPERATING LOAD FOR TIGHTEN BODY MOUNT NUTS & BOLTS VARIES FROM 45 TO 65 FOOT POUND.



60-180 min



Cutting Not Required



Drilling Not Required



support@trailfx.com



1 866 638 4870



WARRANTY POLISHED STAINLESS STEEL – LIMITED LIFETIME
POWDER COATED BLACK – 3 YEARS

PARTS LIST:

Qty	Part Description	Qty	Part Description
1	Bull Bar	16	10mm x 27mm OD x 3mm Flat Washers
1	Driver/Left Frame Mounting Bracket	8	10mm Lock Washers
1	Passenger/Right Frame Mounting Bracket	8	10-1.5mm Hex Nuts
8	10-1.5mm x 35mm Hex Bolts		

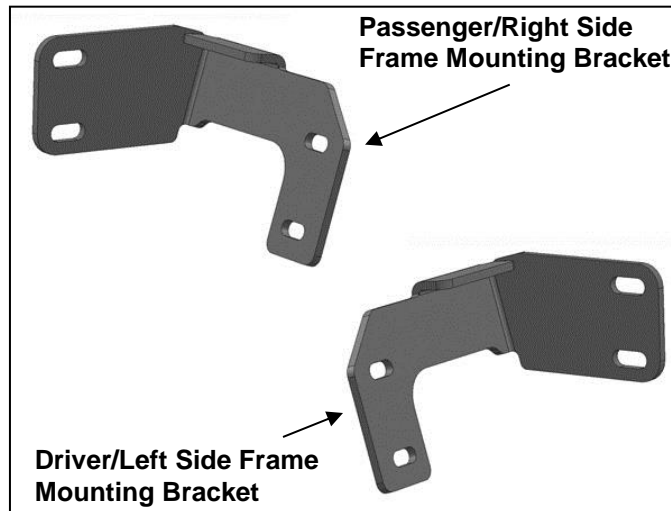

INSTALLATION PROCEDURE:

REMOVE CONTENTS FROM BOX. VERIFY ALL PARTS ARE PRESENT. READ INSTRUCTIONS CAREFULLY BEFORE STARTING INSTALLATION. TOW HOOKS CANNOT BE REINSTALLED WITH BULL BAR. INSTALLATION MAY INTERFERE WITH FRONT BUMPER MOUNTED SENSORS. ASSISTANCE IS RECOMMENDED. NOTE: It may be necessary to remove/relocate front license plate and license plate bracket. It is not required, but strongly recommended. If local/state law requires a visible front license plate, a license plate relocation kit is available.

- Starting at the front of the vehicle, determine if the truck is equipped with or without factory tow hooks, **(Figure 1)**.

Models without tow hooks:

Remove the plastic panel covering the opening in the center of the bumper, **(Figure 1)**.

Models with tow hooks:

Remove the (4) hex bolts attaching the passenger side tow hook to the frame, **(Figures 1 & 2)**. Remove the tow hook, **(Figure 3)**. **TIP:** Removing the inner hex bolts securing each tow hook can be difficult to reach from behind the bumper, (long socket extensions required). It may be easier to access the (2) hex bolts by going through the front of the bumper and holding the hex nuts in place with an open-ended wrench, **(Figure 2)**. Repeat this Step to remove the driver side tow hook.

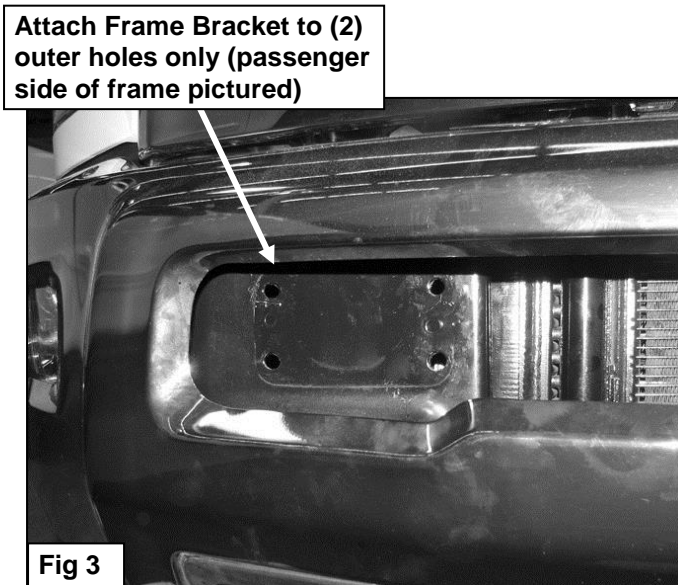
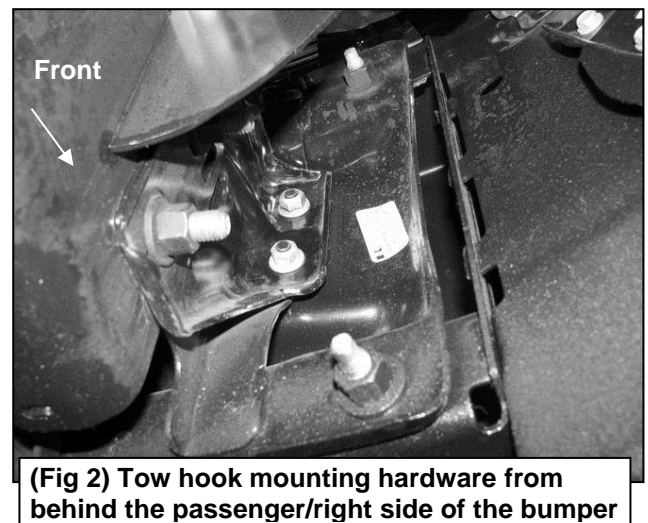
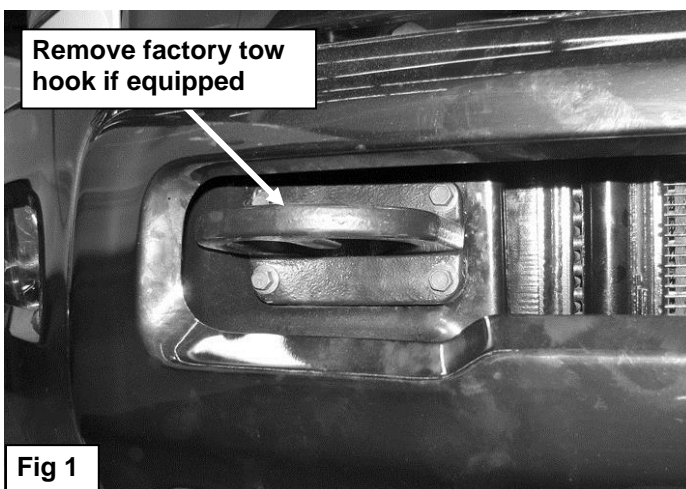

- Select the passenger side Mounting Bracket, **(Figure 4)**. Attach the Bracket to the (2) outer holes for the tow hook with the factory hardware or the included (2) 10mm x 35mm Hex Bolts, (4) 10mm Flat Washers, (2) 10mm Lock Washers and (2) 10mm Hex Nuts, **(Figures 5)**. Snug the hardware but do not tighten at this time.

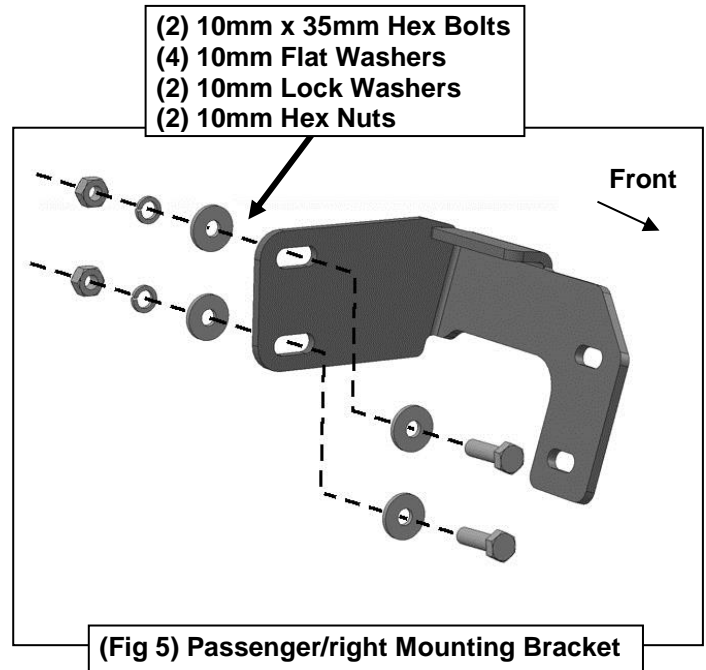
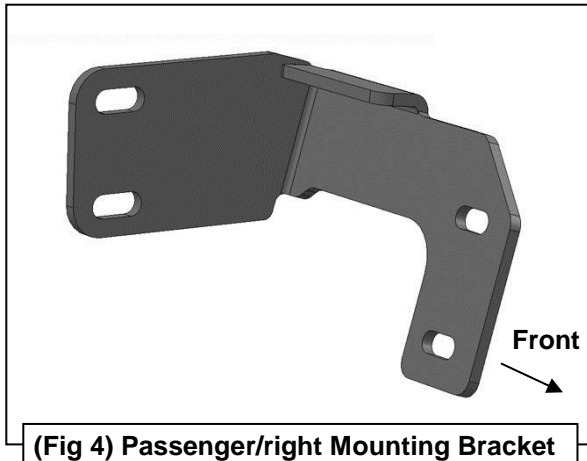

3. Repeat **Step 2** for driver side Mounting Bracket installation.
4. With assistance, position the Bull Bar up to the inside of the Mounting Brackets. Use the included (4) 10mm x 35mm Hex Bolts, (8) 10mm Flat Washers, (4) 10mm Lock Washers and (4) 10mm Hex Nuts to attach the Bull Bar to the Mounting Brackets, **(Figures 6 & 7)**. Snug but do not tighten hardware.

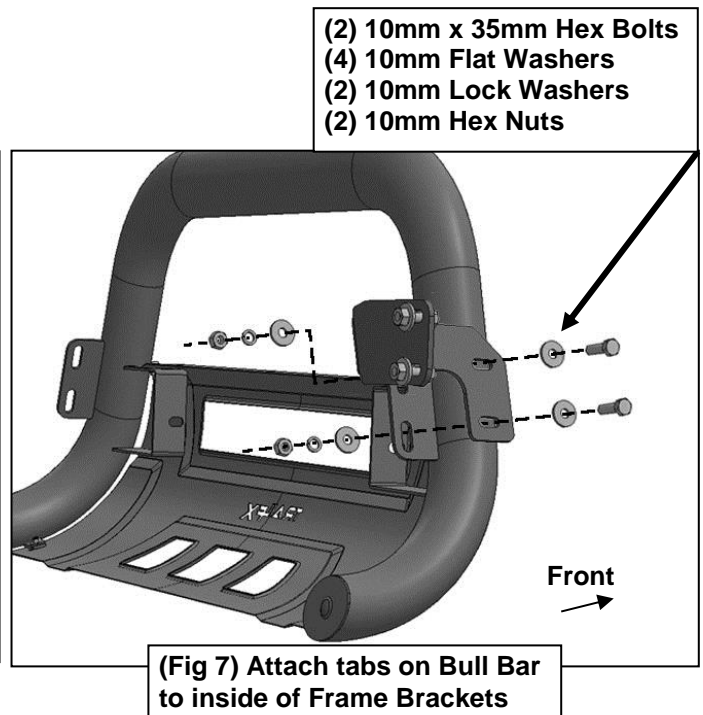
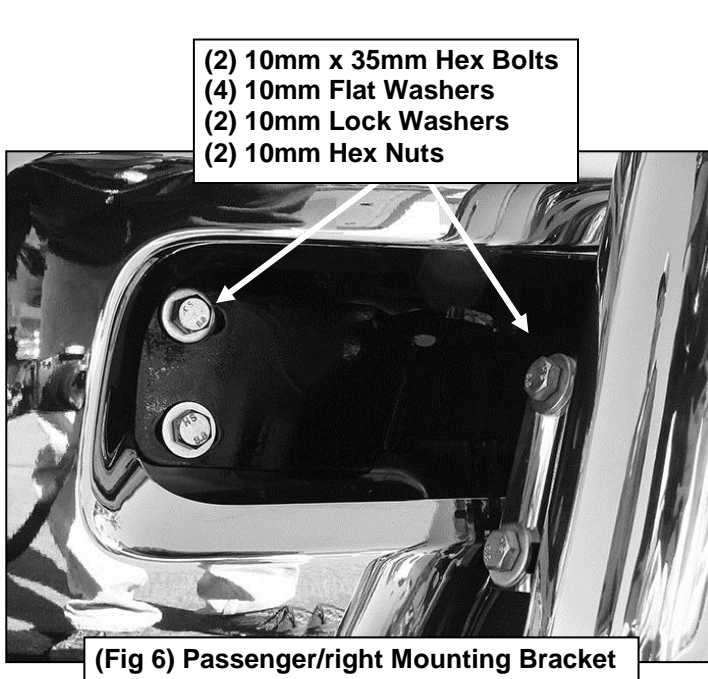

5. Stand back from the vehicle and check to see that the Bull Bar is centered and level on the vehicle and adjust as necessary. Once properly adjusted, tighten all hardware.
6. Do periodic inspections to the installation to make sure that all hardware is secure and tight.

PARTS IDENTIFICATION GUIDE

Driver Side tube packed using "Green" color foam sheet. Passenger Side tube packed using "White" color foam sheet

No.	Parts Identification
1	Passenger / Right 'Rear' Bracket marked "PR"
2	Driver / Left 'Rear' Bracket marked "DR"
3	Passenger / Right 'Center' Bracket marked "PC"
4	Driver / Left 'Center' Bracket marked "DC"
5	Passenger / Right 'Front' Bracket marked "PF"
6	Driver / Left 'Front' Bracket marked "DF"

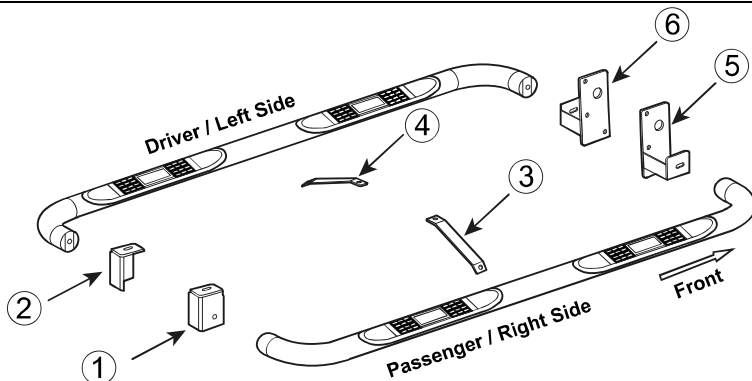

Note:
 > This guide is to identify the parts and not a reference for part count.
 > For part count, refer Parts List.
 > Product / Bracket image is representative and actual design may vary.

PRODUCT CARE

- Periodically check the product to ensure all fasteners are tight and components are intact.
- Regular waxing is recommended to protect the finish of the product.
- **Use ONLY Non-Abrasive automotive wax.** Use of any soap, polish or wax that contains an abrasive is detrimental and can scratch the finish leading to corrosion.
- Aluminum polish may be used to polish small scratches and scuffs for **Stainless Steel finish.**
- Mild soap may be used to clean the product for both **Stainless Steel and Black finish.**

FAQ's

- 1. Hardware's are not of correct size.**
In GMC / Chevrolet truck model 2006 & up, customer needs to reuse the factory body bolts to install the bracket. If your vehicle is not GMC / Chevrolet 2006 & up, ensure that holes are not partially covered with any plastic grommet or rust? If it is, remove the plastic grommet & rust from the thread holes & re-try the installation.
- 2. Mounting Bracket are not getting installed properly.**
In some cases Illustration images shown in Installation manual may not be the exactly same as per actual vehicle images ,also if Driver / Passenger side mounting brackets are very identical in the design, suggest referring Parts Identification guide to avoid fitment issue.
- 3. Products are thumping / rattling after installation.**
Ensure that all required mounting brackets / hardware's are installed & tighten correctly. Suggest using white lithium / regular grease between the metal to metal contact surfaces.
- 4. Side Bar is not aligning with vehicle / Step Pads are not aligning with vehicle doors.**
Side bar may be interchanged or mounting brackets are not installed at the correct position in the vehicle. Refer Parts identification guide.
- 5. Missing / Excess Hardware.**
Recheck hardware count as per the part list.
- 6. Product not installing properly.**
Ensure make model year, cab length and bed size of your vehicle is listed in the application. All installation steps are followed correctly.

Check out these other TrailFX Products!!

www.TrailFX.com



Keystone Automotive Operations Inc. (KAO) warrants this product to be free of defects in material and workmanship at the time of purchase by the original retail consumer. KAO disclaims any other warranties, express or implied, including the warranty of fitness for a particular purpose or an intended use. If the product is found to be defective, KAO may replace or repair the product at our option, when the product is returned prepaid, with proof of purchase. Alteration to, improper installation, or misuse of this product voids the warranty. KAO's liability is limited to repair or replacement of products found to be defective, and specifically excludes liability for any incidental or consequential loss or damage.