

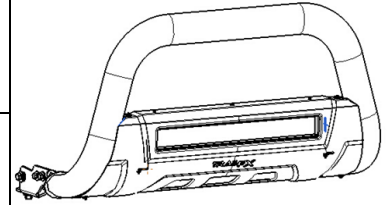

3.5" Oval Bull Bar

Part No. B1608S/B



Fits: 2011-2016 Ford F250/350/450/550 Super Duty



THE BULL BAR MAY INTERFERES WITH PARKING SENSORS, PROXIMITY SENSORS AND CRUISE CONTROL SENSORS.



60-180 min



Cutting Not Required



Drilling Not Required



REMOVE CONTENTS FROM BOX. VERIFY ALL PARTS ARE PRESENT.



support@trailfx.com



READ INSTRUCTIONS CAREFULLY BEFORE STARTING INSTALLATION.



1 866 638 4870

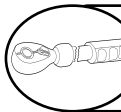

DO NOT OVER TORQUE. STANDARD OPERATING LOAD FOR TIGHTEN BODY MOUNT NUTS & BOLTS VARIES FROM 45 TO 65 FOOT POUND.



POLISHED STAINLESS STEEL – LIMITED LIFETIME
POWDER COATED BLACK – 3 YEARS

PARTS LIST:

Qty	Part Description	Qty	Part Description
1	Bull Bar	8	10mm x 27mm OD x 3mm Flat Washers
1	Driver/left Frame Mounting Bracket	4	10mm Lock Washers
1	Passenger/right Frame Mounting Bracket	4	10mm Hex Nuts
4	10-1.5mm x 30mm Hex Bolts		

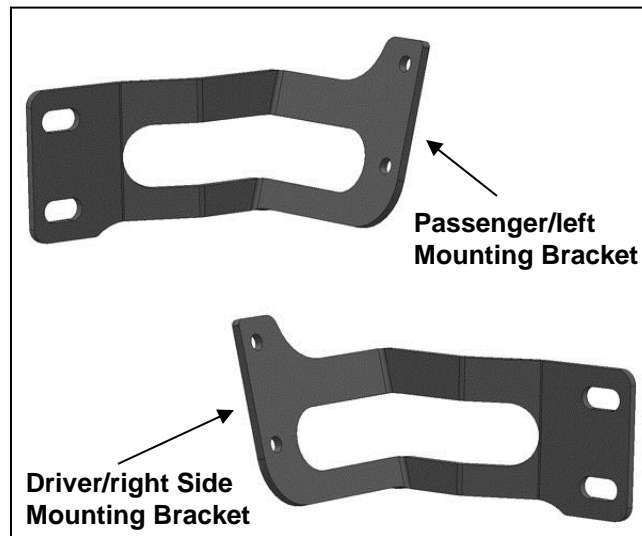

INSTALLATION PROCEDURE:**ASSISTANCE IS RECOMMENDED.**

- NOTE:** It may be necessary to remove/relocate front license plate and bracket. It is not required, but strongly recommended. If local/state law requires a license plate, license plate relocation kit is available.
- Measure the gap between bottom of the headlight assembly and the top of the bumper on the driver and passenger side. Record these measurements for bumper realignment as necessary, **(Step 9)**.
- Start installation at the passenger side, front of the vehicle. Remove the (2) passenger side bumper bolts and double nut plate behind the bumper, **(Figures 1 & 2)**. **WARNING!** Do not loosen or remove the passenger and driver side bumper mounting bolts at the same time or bumper may move out of alignment or fall off of the vehicle. Only remove the bumper bolts from one side and install one Mounting Bracket at a time.

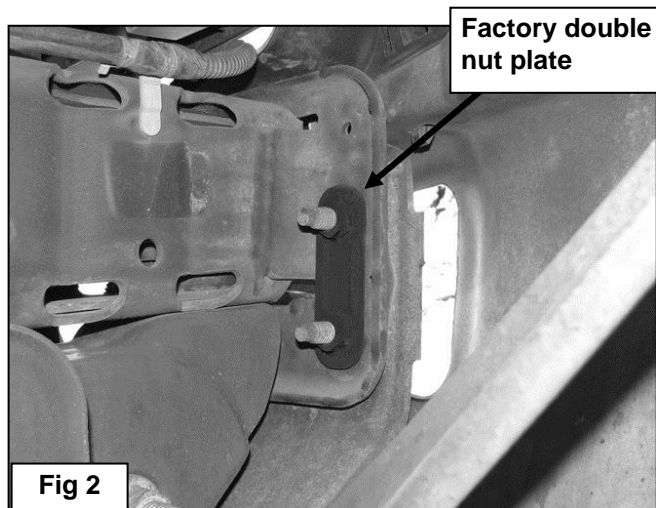
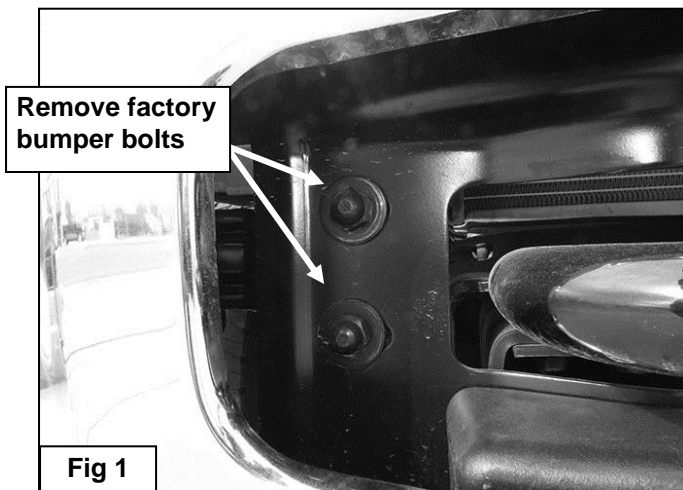

WARNING! Do not loosen or remove passenger and driver side bumper mounting bolts at the same time or bumper may move out of alignment or fall off the vehicle. Only remove the bumper bolts from one side and install one Mounting Bracket at a time.

- Place the passenger side Mounting Bracket onto the vehicle, **(Figure 3)**, and line up the (2) slots with the (2) holes for the bumper bolts. Insert the factory bumper bolts through the Bracket, bumper and into the double nut plate, **(Figure 4)**. **NOTE:** Leave a minimum 1/8" clearance between the top or bottom of the Bracket and the bumper. Fully tighten the bumper bolts at this time.

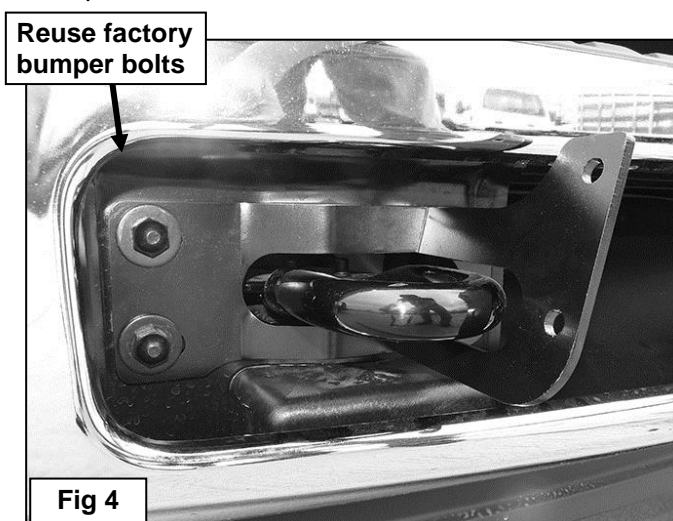

- Repeat **Steps 4—5** for driver side Mounting Bracket installation.
- With assistance, position the Bull Bar onto the outside of the (2) Mounting Brackets. **NOTE:** Move the Mounting Brackets in or out as required to line up with the mounting tabs on the Bull Bar.

7. Attach the Bull Bar to the outside of the Mounting Brackets with the included (4) 10mm x 30mm Hex Bolts, (8) 10mm Flat Washers, (4) 10mm Lock Washers and (4) 10mm Hex Nuts, (**Figures 5 & 6**). Snug but do not tighten hardware at this time.

(2) 10mm x 30mm Hex Bolts
 (4) 10mm Flat Washers
 (2) 10mm Lock Washers
 (2) 10mm Hex Nuts

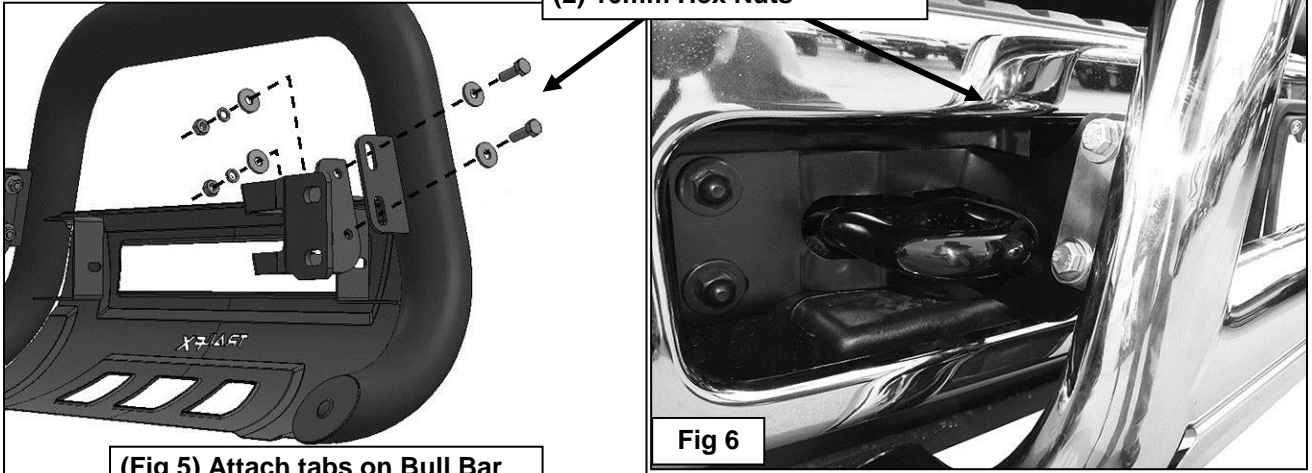

(Fig 5) Attach tabs on Bull Bar to outside of Mounting Brackets

Fig 6

8. Center the Bull Bar on the vehicle, level and adjust as desired and tighten all hardware at this time. Check front bumper alignment and readjust as necessary as mentioned in **Step 3**.
9. Do periodic inspections to the installation to make sure that all hardware is secure and tight.

PRODUCT CARE

- Periodically check the product to ensure all fasteners are tight and components are intact.
- Regular waxing is recommended to protect the finish of the product.
- **Use ONLY Non-Abrasive automotive wax.** Use of any soap, polish or wax that contains an abrasive is detrimental and can scratch the finish leading to corrosion.
- Aluminum polish may be used to polish small scratches and scuffs for **Stainless Steel finish.**
- Mild soap may be used to clean the product for both **Stainless Steel and Black finish.**

FAQ's**1. Hardware's are not of correct size.**

In GMC / Chevrolet truck model 2006 & up, customer needs to reuse the factory body bolts to install the bracket. If your vehicle is not GMC / Chevrolet 2006 & up, ensure that holes are not partially covered with any plastic grommet or rust? If it is, remove the plastic grommet & rust from the thread holes & re-try the installation.

2. Mounting Bracket are not getting Installed properly.

In some cases Illustration images shown in Installation manual may not be the exactly same as per actual vehicle images ,also if Driver / Passenger side mounting brackets are very identical in the design, suggest referring Parts Identification guide to avoid fitment issue.

3. Products are thumping / rattling after installation.

Ensure that all required mounting brackets / hardware's are installed & tighten correctly. Suggest using white lithium / regular grease between the metal to metal contact surfaces.

4. Side Bar is not aligning with vehicle / Step Pads are not aligning with vehicle doors.

Side bar may be interchanged or mounting brackets are not installed at the correct position in the vehicle. Refer Parts identification guide.

5. Missing / Excess Hardware.

Recheck hardware count as per the part list.

6. Product not installing properly.

Ensure make model year, cab length and bed size of your vehicle is listed in the application. All installation steps are followed correctly.

Check out these other TrailFX Products!!

www.TrailFX.com



BULL BAR



GRILLE GUARDS



BED RAILS



RUNNING BOARDS

Keystone Automotive Operations Inc. (KAO) warrants this product to be free of defects in material and workmanship at the time of purchase by the original retail consumer. KAO disclaims any other warranties, express or implied, including the warranty of fitness for a particular purpose or an intended use. If the product is found to be defective, KAO may replace or repair the product at our option, when the product is returned prepaid, with proof of purchase. Alteration to, improper installation, or misuse of this product voids the warranty. KAO's liability is limited to repair or replacement of products found to be defective, and specifically excludes liability for any incidental or consequential loss or damage.