



Grille Guard

Part No. E0034S/B



Fits: 2014 - Current

GMC Sierra 1500



EXCL. DENALI



60-180 min

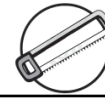

Cutting Required



Drilling Not Required



REMOVE CONTENTS FROM BOX. VERIFY ALL PARTS ARE PRESENT.



support@trailfx.com



READ INSTRUCTIONS CAREFULLY BEFORE STARTING INSTALLATION.



1 866 638 4870

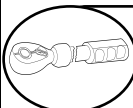

DO NOT OVER TORQUE. STANDARD OPERATING LOAD FOR TIGHTEN BODY MOUNT NUTS & BOLTS VARIES FROM 45 TO 65 FOOT POUND.



WARRANTY POLISHED STAINLESS STEEL – LIMITED LIFETIME
POWDER COATED BLACK – 3 YEARS

PARTS LIST:

Qty	Part Description	Qty	Part Description
1	Grille Guard Assembly	6	12mm Lock Washers
2	Frame Brackets	6	12-1.75mm Hex Nuts
1	Driver/Left Side Mounting Bracket	4	10-1.50mm x 30mm Hex Bolts
1	Passenger/Right Side Mounting Bracket	8	10mm x 27mm x 3mm Flat Washers
1	Driver/Left Top Bracket (for 14-15 MY)	4	10mm Lock Washers
1	Passenger/Right Top Bracket (for 14-15 MY)	4	10-1.50mm Hex Nuts
1	Driver/Left Top Bracket (for 16-18 MY)	2	8-1.25mm x 25mm Button Head Allen Bolts
1	Passenger/Right Top Bracket (for 16-18 MY)	6	8-1.25mm x 25mm Hex Bolts
2	50mm x 150mm Adhesive Foam Tapes	10	8mm x 24mm x2mm Flat Washers
2	12-1.75mm x 30mm Double Bolt Plates	6	8mm Lock Washers
2	12-1.75mm x 35mm Single Bolt Plates	2	8-1.25mm Nylon Lock Nuts
6	12mm x 24mm x 2.5mm Flat Washers	1	Allen Wrench S=5

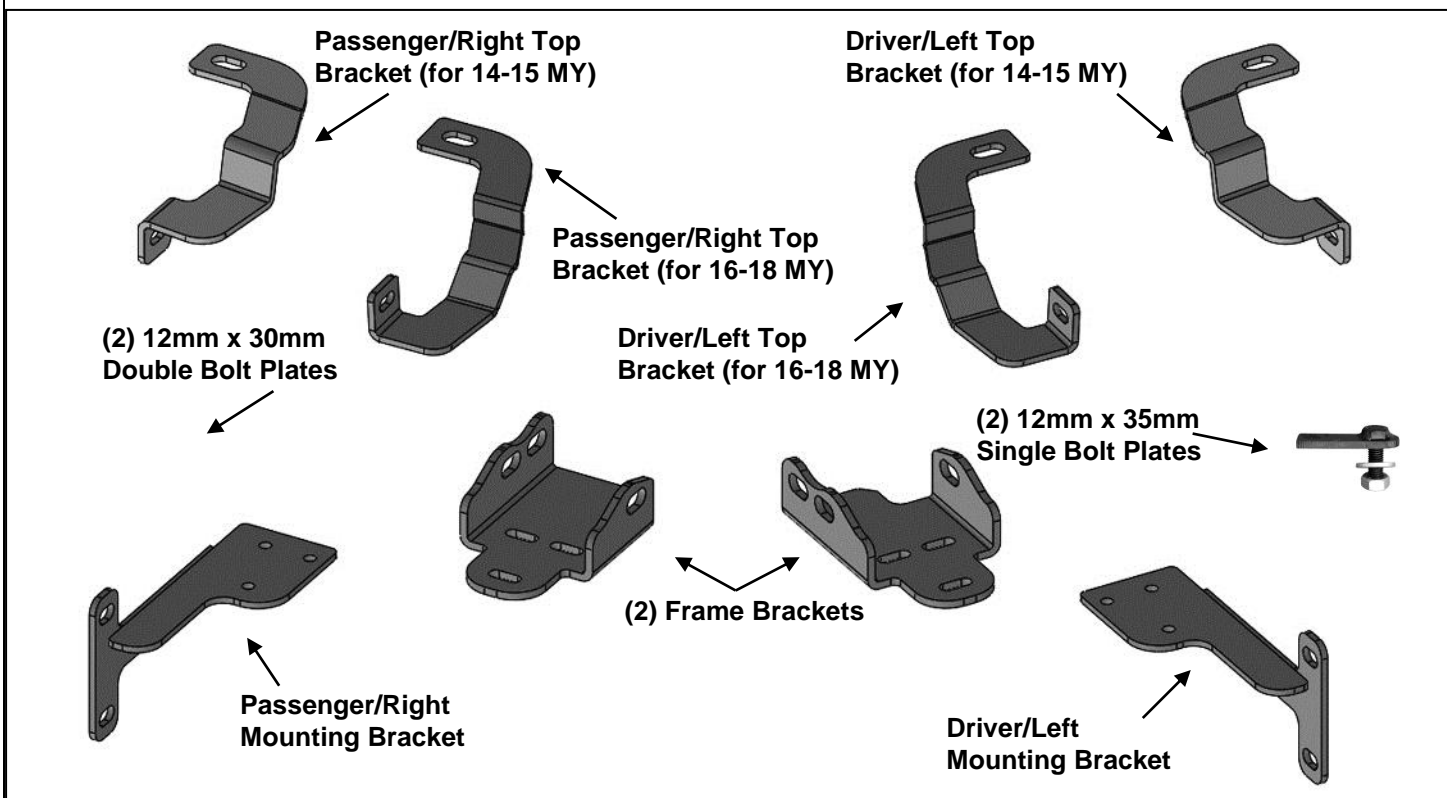

INSTALLATION PROCEDURE:

DO NOT ATTEMPT INSTALLATION ALONE; PERSONAL INJURY OR DAMAGE TO THE VEHICLE MAY RESULT. CUTTING MAY BE REQUIRED. ASSISTANCE IS HIGHLY RECOMMENDED. INSTALLATION MAY INTERFERE WITH FRONT MOUNTED SENSORS.

1. Start installation from the front of the vehicle. Locate and remove the screws attaching the ends of the plastic body panel, (fascia), to the fenders, **(Figures 1 & 2)**. **NOTE:** Fascia body panel fills the area between the headlights and the top of the bumper and must be removed to access the bumper bolts.
2. From behind the bumper, release the clips attaching the fascia panel to the bottom of the grille and remove the panel, **(Figures 3 & 4)**.
3. Next, open the hood and remove the plastic cover from the top of the radiator and the grille, **(Figure 5)**. Locate and remove the hardware attaching the top and bottom of the grille, **(Figures 6 & 7)**. Carefully pull the grille straight out from the vehicle.
4. Determine if the vehicle is equipped with tow hooks, **(Figure 8)**. **IMPORTANT:** Tow hooks cannot be reinstalled with the Grille Guard.

Tow Hook equipped vehicles:

- a. On the passenger side, locate the (2) bumper bracket bolts from the top of the bumper, **(Figure 9)**. Remove the bottom bolt and loosen the top bumper bolt to help tilt the bumper and remove the long hex bolt through the tow hook. Repeat this Step to remove driver side tow hook.
- b. **NOTE:** If necessary, loosen and/or completely remove the outer support Brackets attaching the bumper to the frame to help tilt the bumper forward, **(Figure 10)**.
- c. Once both tow hooks have been removed and the openings have been checked for Bracket clearance, reinstall the bottom bumper Bracket bolts and support bracket hardware, if removed.
- d. Only tighten the bottom bumper bracket bolts and outer support Bracket hardware at this time.
- e. Proceed to **Step 5**.

Vehicles without tow hooks:

- a. Cut out the lower portion of the indented area in both sides of the plastic bumper insert to clear the Brackets, **(Figures 11 & 12)**. **IMPORTANT:** Make several small cuts for best fit.
5. Starting on the passenger side, select (1) Frame Bracket. Insert the Bracket through the opening in the passenger side of the plastic bumper, **(Figures 13 & 14)**. Line up the (3) holes in the Bracket with the holes in the end of the frame.
6. Select (1) 12mm Double Bolt Plate, **(Figure 15A)**. Insert the Bolt Plate into the end of the frame channel, through the (2) holes in the side of the frame and out through the Bracket. Secure the Bracket to the Double Bolt Plate with (2) 12mm Flat Washers, (2) 12mm Lock Washers and (2) 12mm Hex Nuts, **(Figure 15B)**. Snug but do not fully tighten hardware at this time. Repeat this **Step** to install the 12mm x 35mm Single Bolt Plate, **(Figure 16A)**, into the remaining hole in the other side of the frame channel and through the Bracket, **(Figure 16B)**.
7. Next, select the passenger side Mounting Bracket, **(Figure 17)**. Attach the Mounting Bracket to the bottom of the Frame Bracket with (3) 8mm x 25mm Hex Bolts, (3) 8mm Lock Washers and (3) 8mm Flat Washers, **(Figures 17 & 18)**. Do not tighten hardware at this time.
8. Repeat **Steps 5—7** to install the driver side Frame and Mounting Brackets.
9. Starting on the passenger side, locate and remove the top factory bumper bolt, **(Figure 19)**. Depending on the model year of the vehicle, select either the passenger side 14-15 Top Bracket or passenger side 16-18 Top Bracket, **(Figure 20)**. Apply a layer of Adhesive Foam Tape to the Top Bracket to protect the finish on the bumper, **(Figure 21)**. Reuse the factory top bumper bolt to attach the Top Bracket to the vehicle, **(Figures 22 & 23)**. Leave hardware loose at this time.
10. Repeat **Step 9** to attach the appropriate driver side Top Bracket to the top of the bumper bracket.
11. With assistance, hold the Grille Guard up in position on the outside of the Mounting Brackets. Attach the Grille Guard to the Brackets with (4) 10mm Hex Bolts, (8) 10mm Flat Washers, (4) 10mm Lock Washers and (4) 10mm Hex Nuts, **(Figures 24—26)**. Snug but do not tighten hardware.
12. Check the Grille Guard alignment with the vehicle. Adjust as required then tighten first the Frame Bracket hardware, then the (6) 8mm Hex Bolts securing the Mounting Brackets to the bottom of the Frame Brackets. Do not fully tighten the Grille Guard to Bracket hardware at this time.
13. Line up the outer bent end of the passenger side Top Support Bracket with the hole in the Grille Guard upright. Attach the Top Bracket to the Grille Guard with (1) 8mm Button Head Bolt, (2) 8mm Flat Washers and (1) 8mm Nylon Lock Nut, **(Figures 24—26)**.
14. Repeat **Step 13** to attach the driver side Top Support Bracket to the Grille Guard.
15. Level and adjust the Grille Guard and fully tighten all brackets to frame hardware only.
16. Temporarily remove the Grille Guard and reinstall the plastic body panel, (fascia), grille and cover.
17. Repeat **Steps 11—15** to reinstall the Grille Guard.
18. Do periodic inspections to the installation to make sure that all hardware is secure and tight.

Passenger/right Installation Pictured

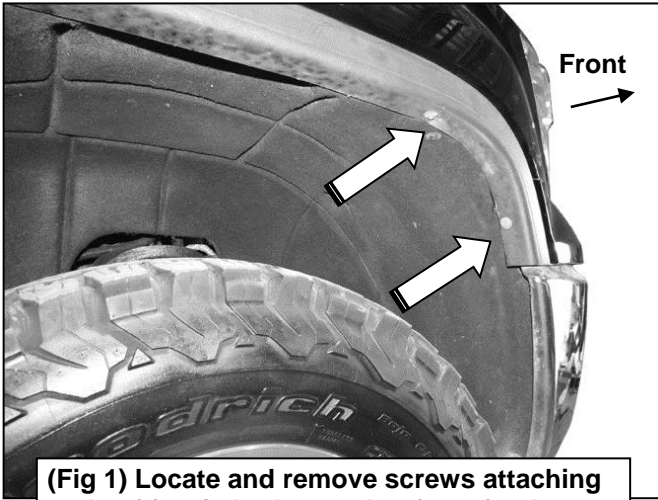

(Fig 1) Locate and remove screws attaching ends of fascia body panel to front fenders

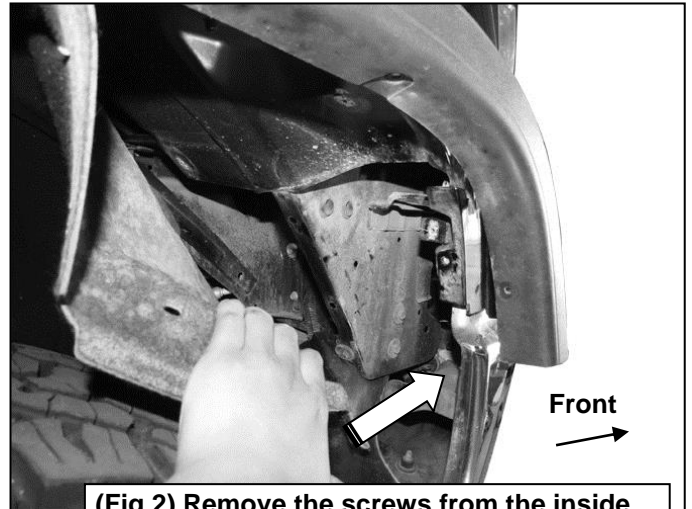

(Fig 2) Remove the screws from the inside of the fender to remove the body panel

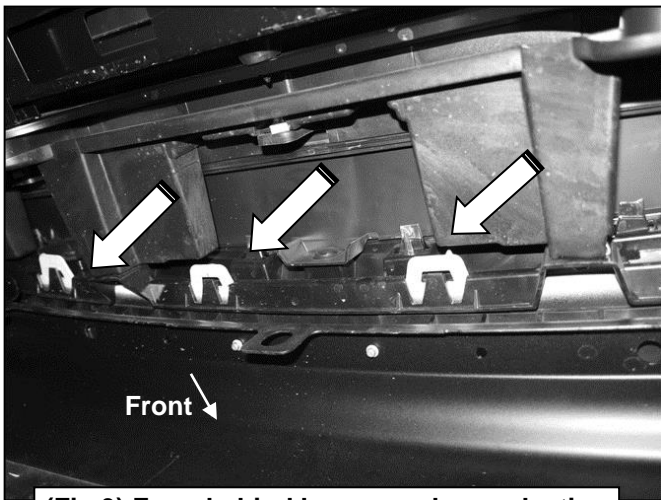

(Fig 3) From behind bumper release plastic clips to remove fascia body panel

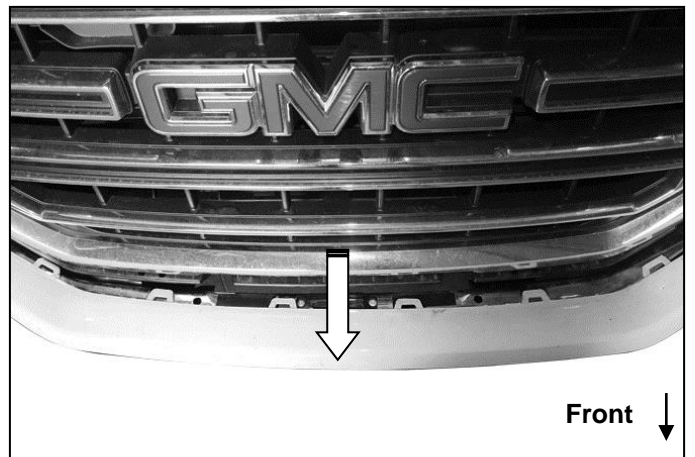

(Fig 4) Remove the fascia body panel to access the top bumper bolts and remove tow hooks, if equipped

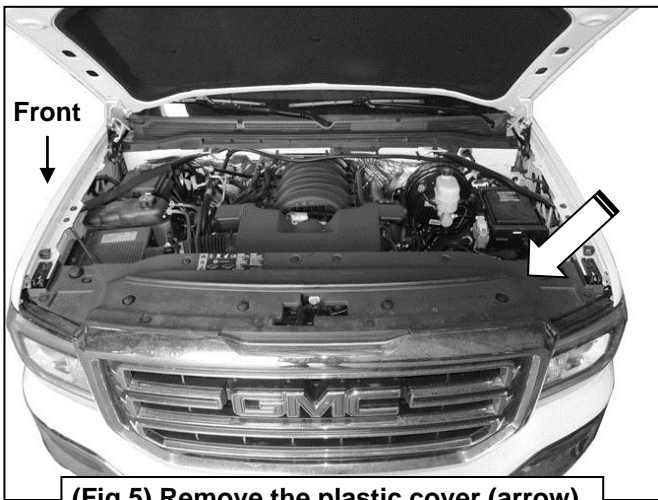

(Fig 5) Remove the plastic cover (arrow)

Passenger/right Installation Pictured

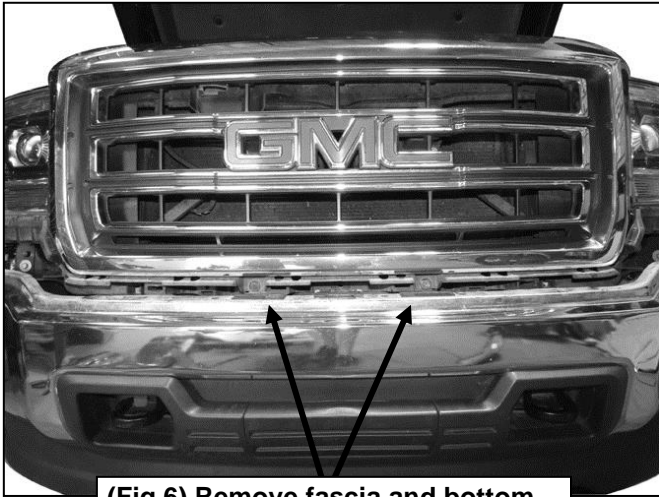

(Fig 6) Remove fascia and bottom bolts attaching grille to the vehicle

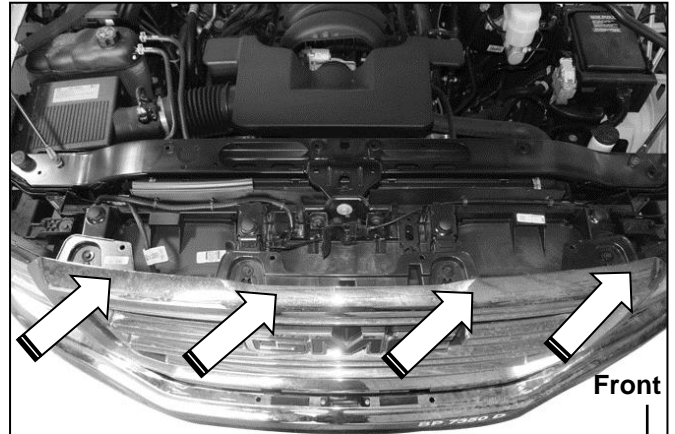

(Fig 7) Remove the top bolts from the grille and carefully pull and remove grille



(Fig 8) Opening for tow hook pictured

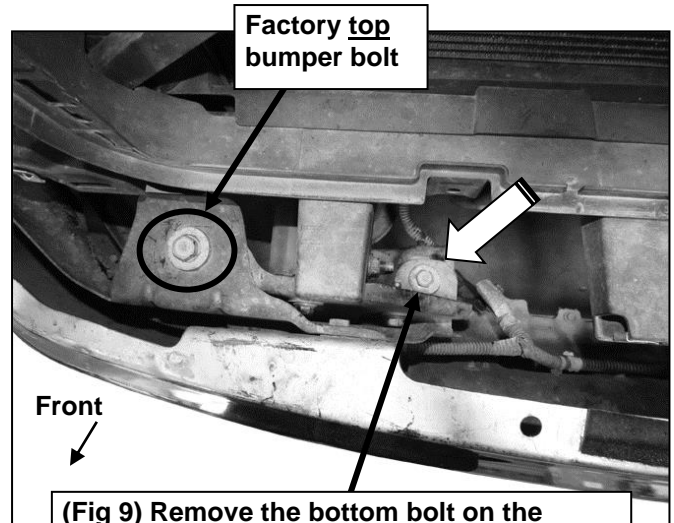

(Fig 9) Remove the bottom bolt on the bumper Bracket, (passenger side pictured)

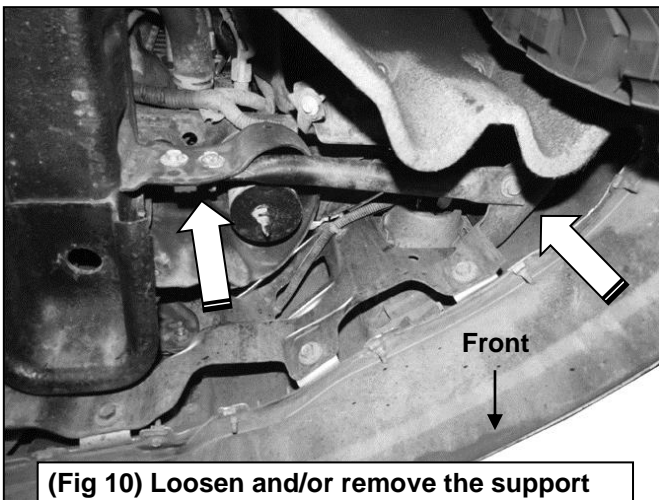

(Fig 10) Loosen and/or remove the support bracket attaching the bumper to the frame to help tilt bumper, (passenger side pictured)

Passenger/right Installation Pictured

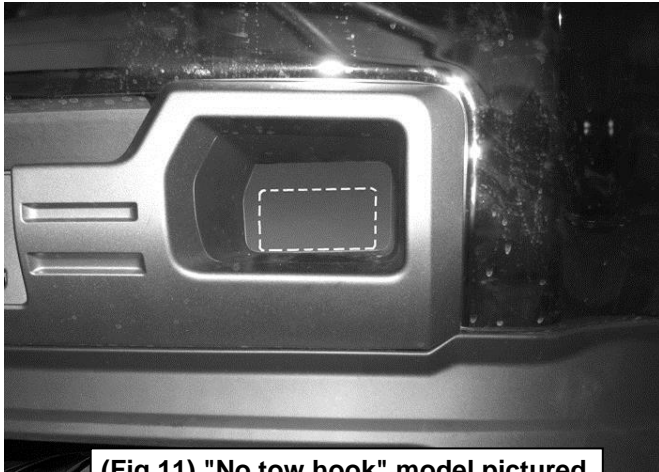

(Fig 11) "No tow hook" model pictured

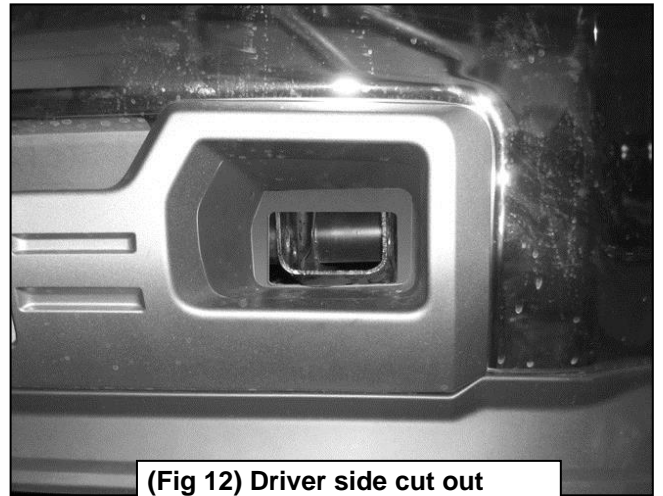

(Fig 12) Driver side cut out illustrated for reference only

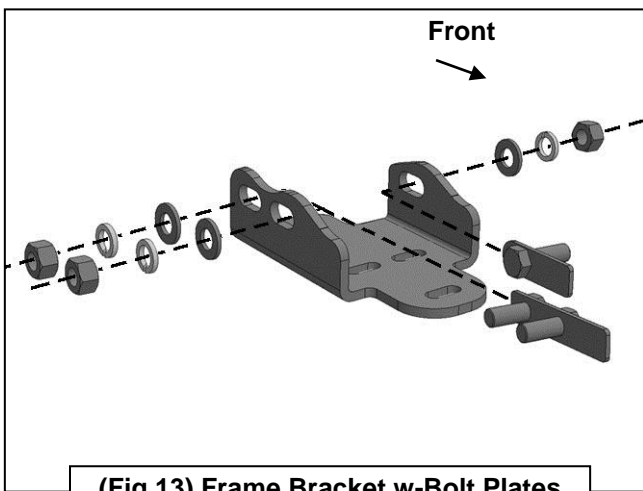

(Fig 13) Frame Bracket w-Bolt Plates

Locate mounting holes in end of frame for factory tow hooks

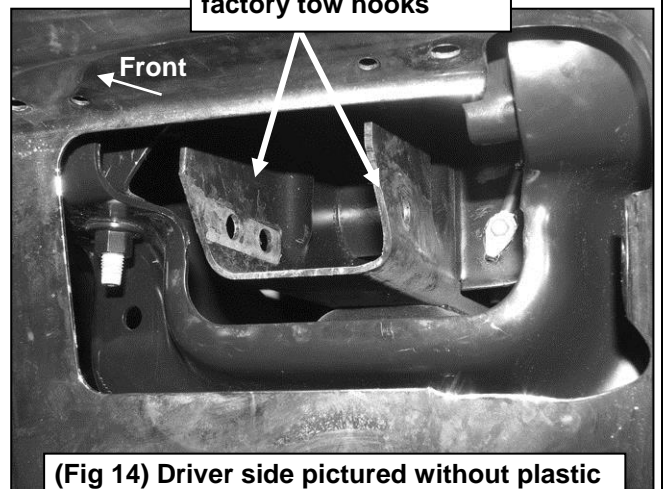

(Fig 14) Driver side pictured without plastic panel for instruction purposes only

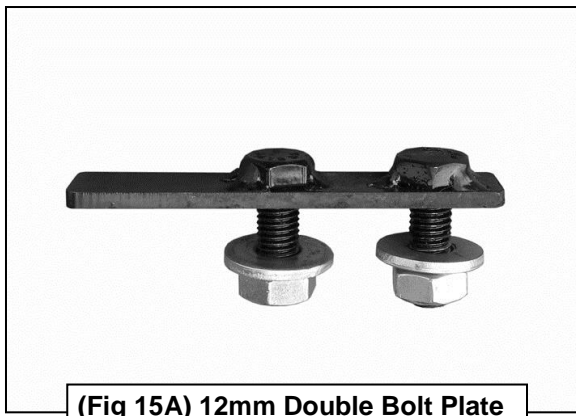

(Fig 15A) 12mm Double Bolt Plate

Passenger/right Installation Pictured

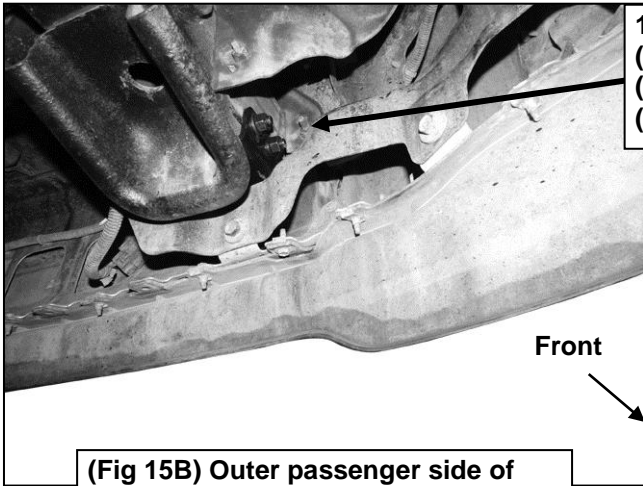

- 12mm Double Bolt Plate
- (2) 12mm Flat Washers
- (2) 12mm Lock Washers
- (2) 12mm Hex Nuts

(Fig 15B) Outer passenger side of Frame Bracket with double bolt plate

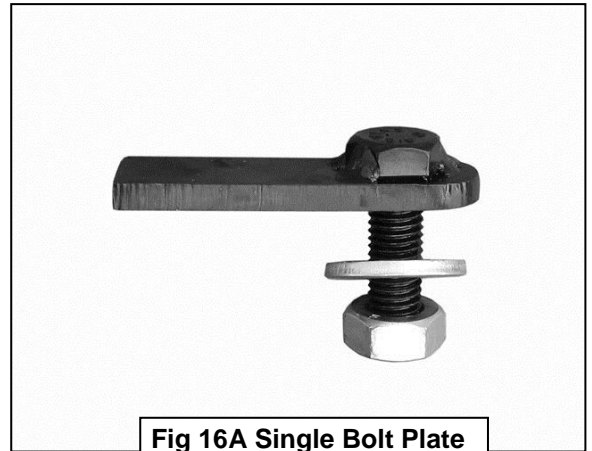
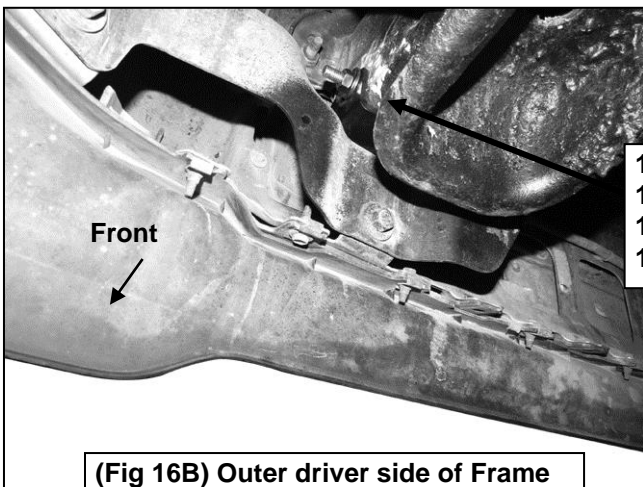

Fig 16A Single Bolt Plate



- 12mm Bolt Plate
- 12mm Flat Washer
- 12mm Lock Washer
- 12 mm Hex Nuts

(Fig 16B) Outer driver side of Frame Bracket with single bolt plate

- Bolt the Mounting Bracket to the bottom of the Frame Bracket with:**
- (3) 8mm x 25mm Hex Bolts
 - (3) 8mm Lock Washers
 - (3) 8mm Flat Washers

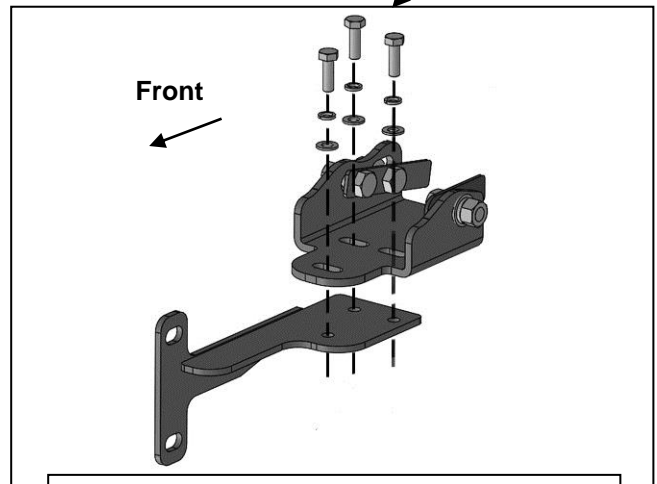

(Fig 17) Passenger side Mounting Bracket attached to Frame Bracket illustrated

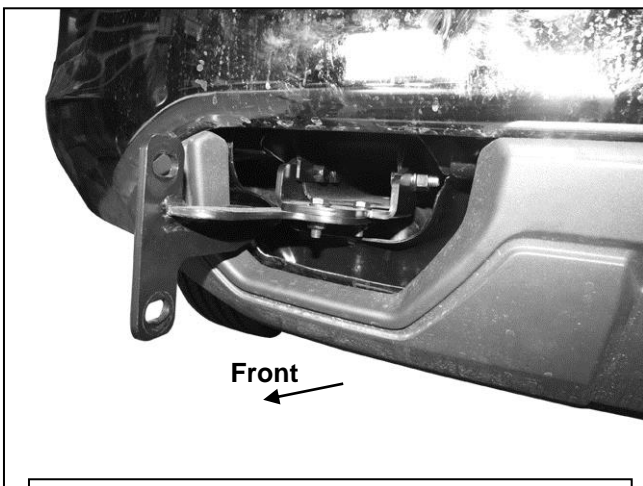

(Fig 18) Passenger side Mounting Bracket attached to the bottom of the Frame bracket

Passenger/right Installation Pictured

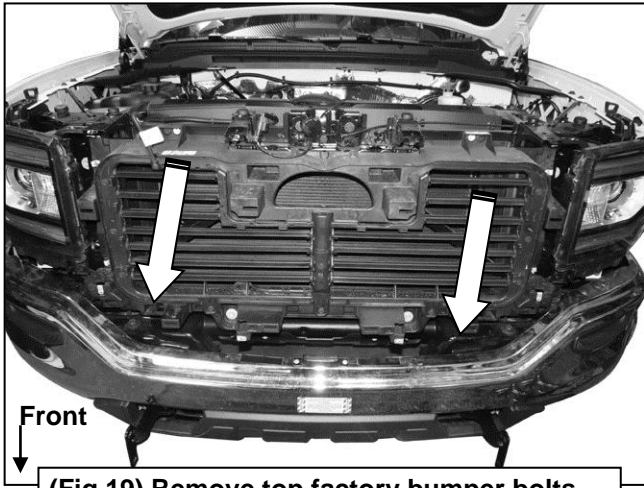

(Fig 19) Remove top factory bumper bolts

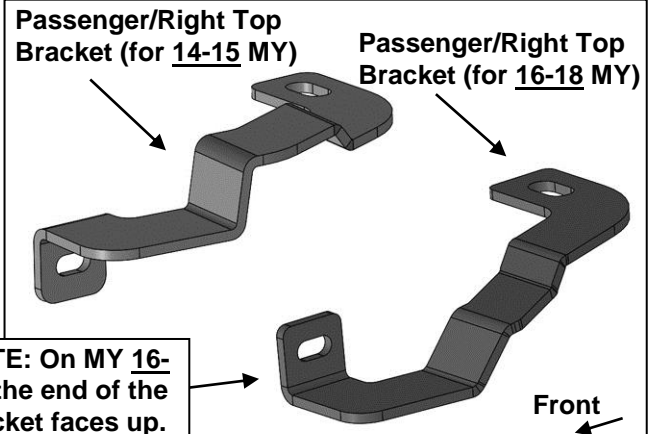

(Fig 20) Passenger side Top Brackets illustrated

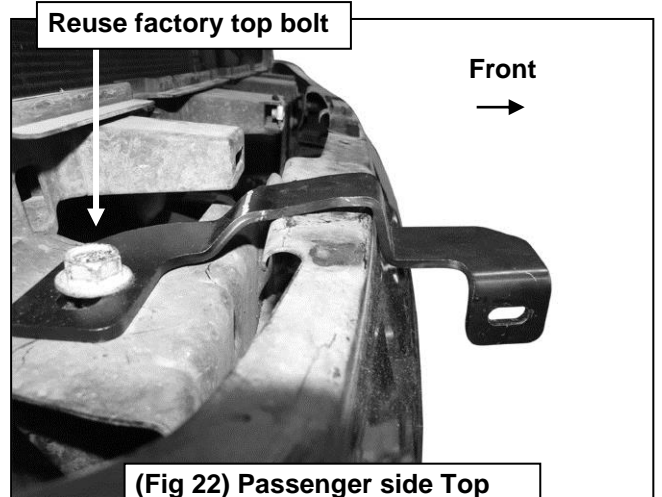
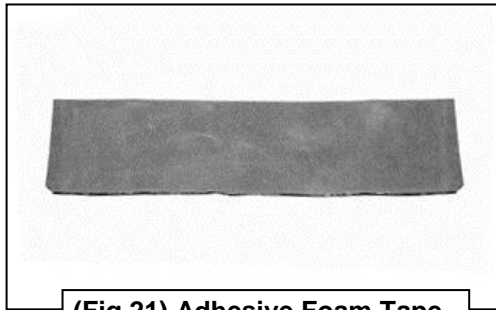

(Fig 22) Passenger side Top Bracket for model years 14-15

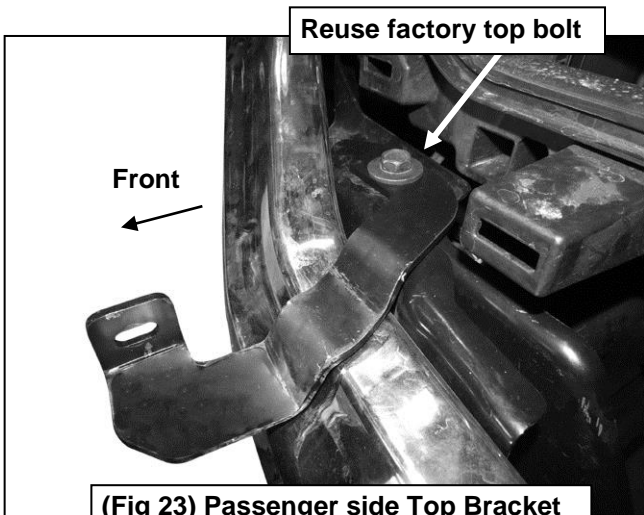

(Fig 23) Passenger side Top Bracket for model years 16-18

Passenger/right Installation Pictured

Bolt the Top Bracket to the Grille Guard with:
 (1) 8mm Button Head Bolt
 (2) 8mm Flat Washers
 (1) 8mm Nylon Lock Nut

Model year 14-15 Passenger side Top Bracket

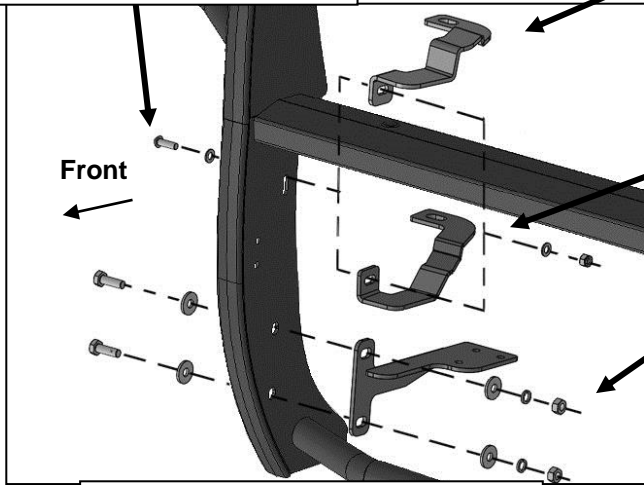

Model year 16-18 Passenger side Top Bracket

(2) 10mm Hex Bolts
 (4) 10mm Flat Washers
 (2) 10mm Lock Washers
 (2) 10mm Hex Nuts

(Fig 24) Passenger side Brackets attached to Grille Guard

Mounting holes for optional parking sensor relocation kit (available separately)

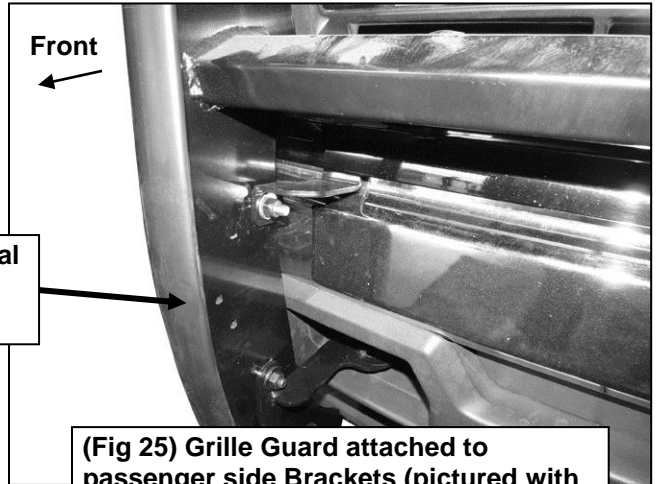

(Fig 25) Grille Guard attached to passenger side Brackets (pictured with MY 14-15 Top Bracket)



(Fig 26) Grille Guard attached to passenger side Brackets (pictured with MY 16-18 Top Bracket)



PRODUCT CARE

- Periodically check the product to ensure all fasteners are tight and components are intact.
- Regular waxing is recommended to protect the finish of the product.
- **Use ONLY Non-Abrasive automotive wax.** Use of any soap, polish or wax that contains an abrasive is detrimental and can scratch the finish leading to corrosion.
- Aluminum polish may be used to polish small scratches and scuffs for **Stainless Steel finish.**
- Mild soap may be used to clean the product for both **Stainless Steel and Black finish.**

FAQ's**1. Hardware's are not of correct size.**

In GMC / Chevrolet truck model 2006 & up, customer needs to reuse the factory body bolts to install the bracket. If your vehicle is not GMC / Chevrolet 2006 & up, ensure that holes are not partially covered with any plastic grommet or rust? If it is, remove the plastic grommet & rust from the thread holes & re-try the installation.

2. Mounting Bracket are not getting Installed properly.

In some cases Illustration images shown in Installation manual may not be the exactly same as per actual vehicle images ,also if Driver / Passenger side mounting brackets are very identical in the design, suggest referring Parts Identification guide to avoid fitment issue.

3. Products are thumping / rattling after installation.

Ensure that all required mounting brackets / hardware's are installed & tighten correctly. Suggest using white lithium / regular grease between the metal to metal contact surfaces.

4. Side Bar is not aligning with vehicle / Step Pads are not aligning with vehicle doors.

Side bar may be interchanged or mounting brackets are not installed at the correct position in the vehicle. Refer Parts identification guide.

5. Missing / Excess Hardware.

Recheck hardware count as per the part list.

6. Product not installing properly.

Ensure make model year, cab length and bed size of your vehicle is listed in the application. All installation steps are followed correctly.

Check out these other TrailFX Products!!

www.TrailFX.com



Keystone Automotive Operations Inc. (KAO) warrants this product to be free of defects in material and workmanship at the time of purchase by the original retail consumer. KAO disclaims any other warranties, express or implied, including the warranty of fitness for a particular purpose or an intended use. If the product is found to be defective, KAO may replace or repair the product at our option, when the product is returned prepaid, with proof of purchase. Alteration to, improper installation, or misuse of this product voids the warranty. KAO's liability is limited to repair or replacement of products found to be defective, and specifically excludes liability for any incidental or consequential loss or damage.