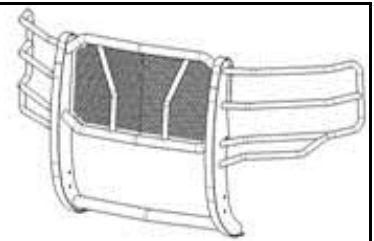




# Extreme Grille Guard

Part No. E0507B



Fits: 2014 - 2016

GMC Sierra 1500 Excludes Denali



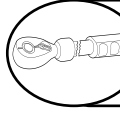
May interfere in vehicles with LED Halo Light & front mounting Parking Sensors. Excludes Denali Models



REMOVE CONTENTS FROM BOX. VERIFY ALL PARTS ARE PRESENT.



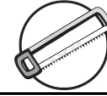
READ INSTRUCTIONS CAREFULLY BEFORE STARTING INSTALLATION.



DO NOT OVER TORQUE. STANDARD OPERATING LOAD FOR TIGHTEN BODY MOUNT NUTS & BOLTS VARIES FROM 45 TO 65 FOOT POUND.



60-180 min



Cutting Required



Drilling Not Required



support@trailfx.com



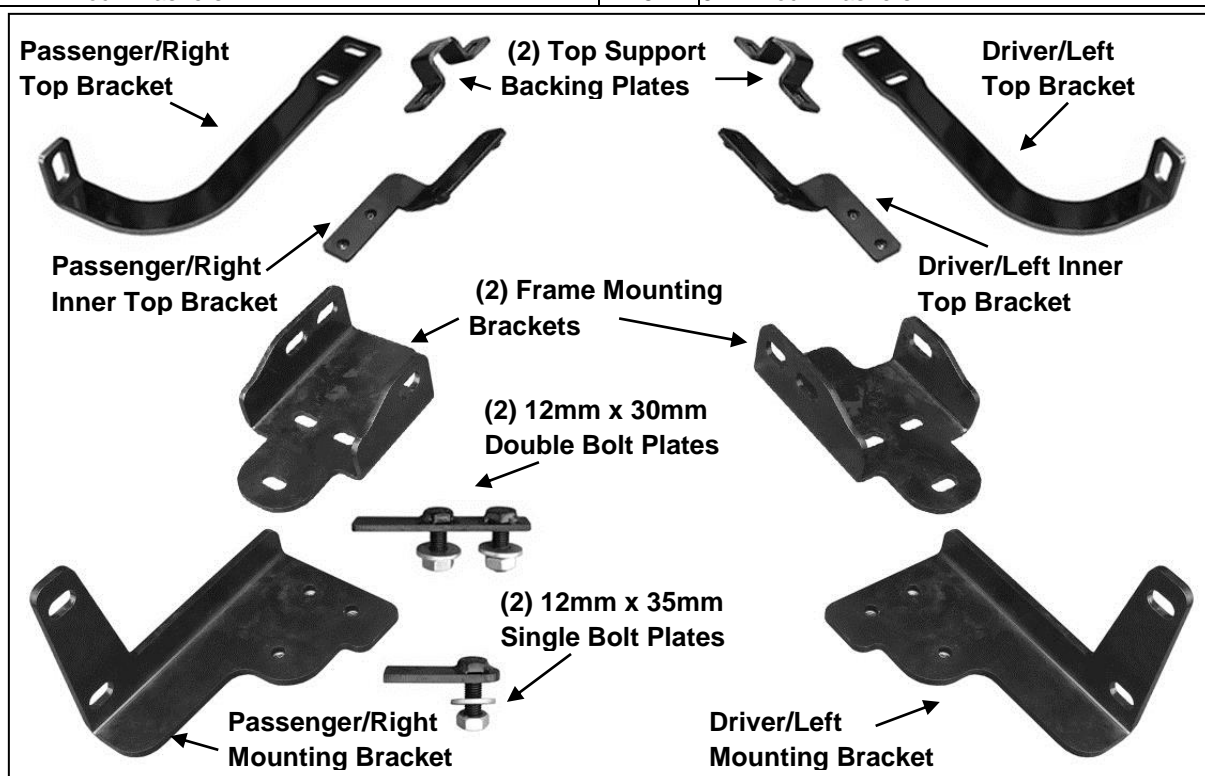
1 866 638 4870



POLISHED STAINLESS STEEL – LIMITED LIFETIME  
POWDER COATED BLACK – 3 YEARS

### PARTS LIST:

Qty	Part Description	Qty	Part Description
1	Grille Guard Assembly	6	12-1.75mm Hex Nuts
2	Frame Brackets	4	10-1.50mm x 30mm Hex Bolts
1	Driver/Left Mounting Bracket	8	10mm x 27mm OD x 3mm Flat Washers
1	Passenger/Right Mounting Bracket	4	10mm Lock Washers
1	Driver/Left Top Bracket	4	10-1.50mm Hex Nuts
1	Passenger/Right Top Bracket	2	8-1.25mm x 25mm Button Head Allen Bolts
1	Driver/Left Top Inner Support Bracket	6	8-1.25mm x 25mm Hex Bolts
1	Passenger/Right Top Inner Support Bracket	10	8mm x 16mm OD x 1.6mm Flat Washers
2	Top Support Rear Backing Plates	6	8mm Lock Washers
2	12-1.75mm x 30mm Double Bolt Plates	2	8-1.25mm Nylon Lock Nuts
2	12-1.75mm x 35mm Single Bolt Plates	8	6-1.0mm x 25mm Hex Bolts
6	12mm x 24mm OD x 2.5mm Flat Washers	8	6mm x 18mm OD x 1.6mm Flat Washers
6	12mm Lock Washers	8	6mm Lock Washers



## INSTALLATION PROCEDURE:

**DO NOT ATTEMPT INSTALLATION ALONE; PERSONAL INJURY OR DAMAGE TO THE VEHICLE MAY RESULT. CUTTING MAY BE REQUIRED. GRILLE GUARD IS HEAVY, ASSISTANCE IS HIGHLY RECOMMENDED. INSTALLATION MAY INTERFERE WITH FRONT MOUNTED SENSORS.**

1. Start installation from under the front of the vehicle. Determine if the vehicle is equipped with tow hooks. **IMPORTANT:** Tow hooks cannot be reinstalled with the Grille Guard.

### Tow Hook equipped vehicles:

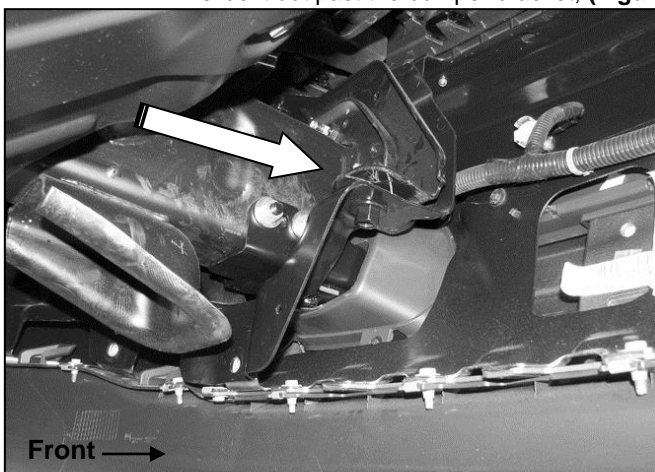
- a. Remove the factory tow hook from the end of each frame channel, **(Figure 1)**. **NOTE:** The driver side tow hook removal is difficult and assistance is highly recommended.



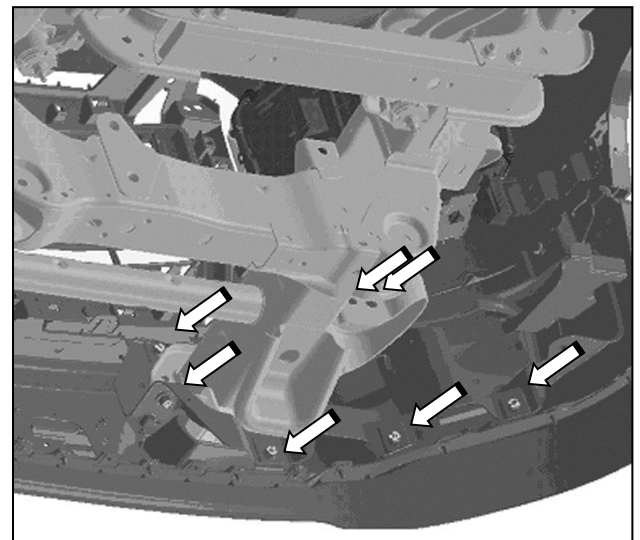
**(Fig 1) Opening for tow hook pictured**

Remove the bolts securing the driver side of the bumper to the bumper bracket. Use a large screwdriver or pry bar to move the mounting tab up to get the long bolt through the tow hook out of the end of the frame

**Option 1:** Remove the hex bolts securing the driver side of the bumper to the bracket. Use a short pry bar or large screwdriver to move the tab on the bumper bracket up and away to clear the hex bolt and slide it out past the bumper bracket, **(Figures 2A, 2B & 4)**.

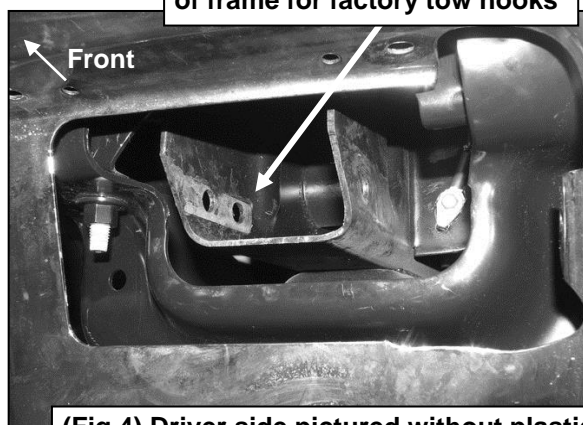


**(Fig 2A) Driver side pictured from behind bumper**



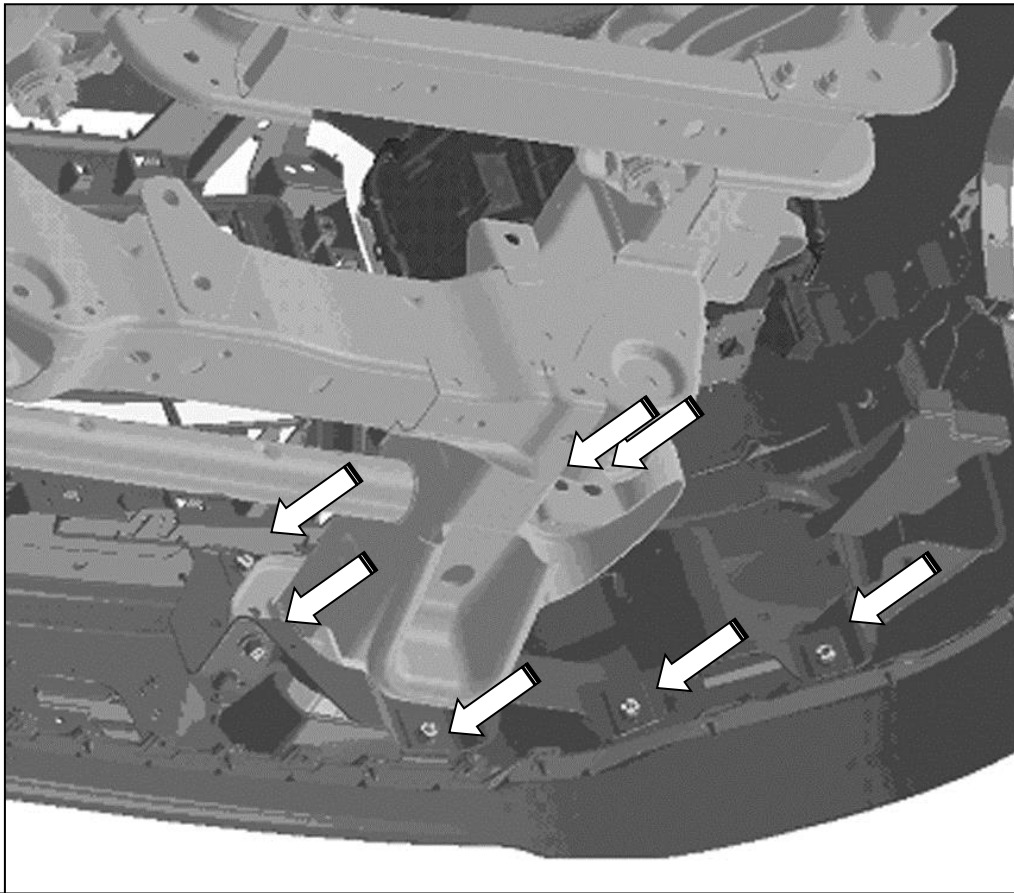
**(Fig 2B) Passenger side illustrated from behind bumper to show bumper bolt locations**

Locate mounting holes in end of frame for factory tow hooks



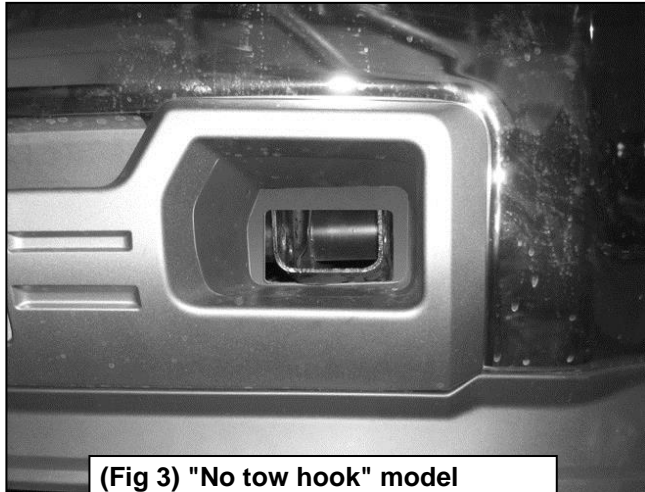
**(Fig 4) Driver side pictured without plastic panel for instruction purposes only**

**Option 2:** Remove the plastic radiator grille. Loosen and/or completely remove the front bumper to remove the long hex bolts in the tow hooks, **(Figure 2B)**.



**(Fig 2B) Passenger side illustrated from behind bumper to show bumper bolt locations**

- b. Reattach the bumper after the tow hooks have been removed and the openings have been checked for Bracket clearance, **(Figure 3)**. Tighten all factory bumper hardware.



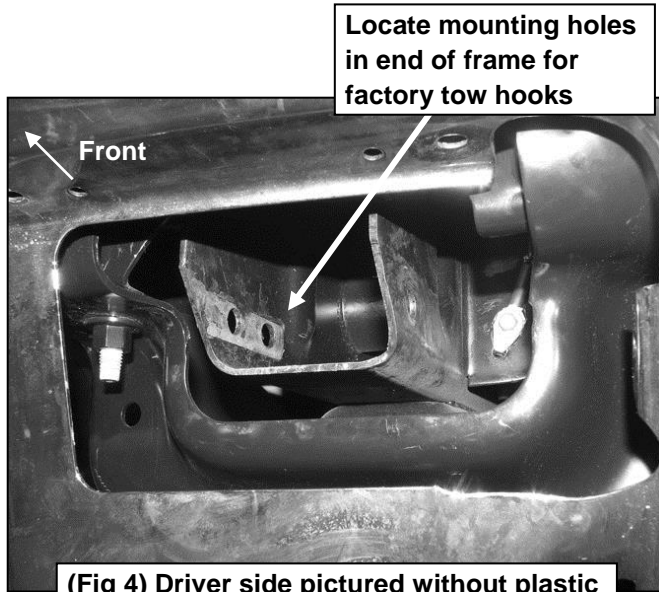
**(Fig 3) "No tow hook" model pictured cut out for reference only**

- c. Proceed to **Step 2**.

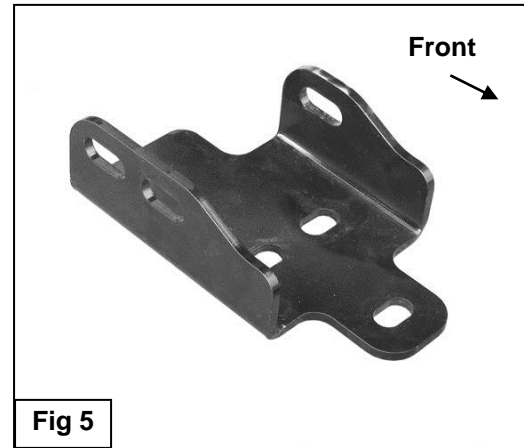
**Vehicles without tow hooks:**

- a. Cut out the indented area in both sides of the plastic bumper insert to clear the Brackets as pictured in **Figures 3 & 4**. **IMPORTANT:** Make several small cuts for best fit. Do not cut through the top edge of the panel. **NOTE:** The plastic panel is held in place with several small screws. The screws at the top corners are difficult to reach and remove with the bumper in place without damaging the cover. If you prefer to remove the panel to cut out the openings, it may be easier to remove the plastic grille first and then the steel bumper with the plastic panel attached, to access all of the small hardware.
- b. Reattach the bumper and/or bumper insert, (if removed), once openings have been cut out and checked for clearance, **(Figure 3)**. Tighten all factory bumper hardware at this time.

2. Locate the holes in the end of the frame channel, **(Figure 4)**. Select (1) Frame Bracket, **(Figure 5)**. Insert the Bracket through the opening in the bumper. Line up the (3) holes in the Bracket with the holes in the side of the frame.

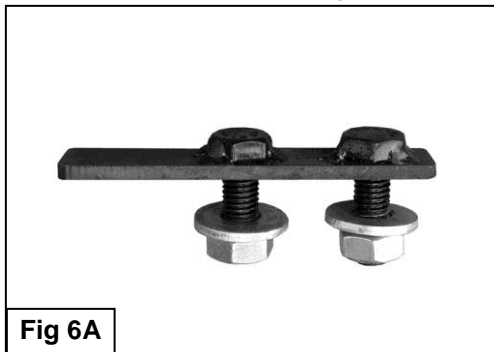


**(Fig 4) Driver side pictured without plastic panel for instruction purposes only**

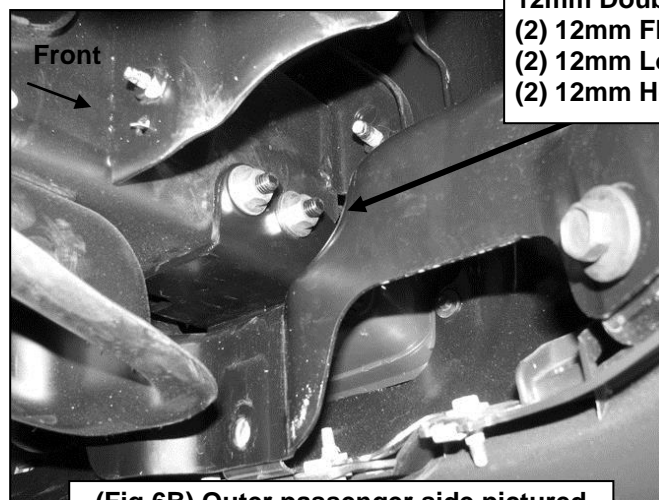


**Fig 5**

3. Select (1) 12mm Double Bolt Plate, **(Figure 6A)**. Insert the Bolt Plate into the end of the frame channel, through the (2) holes in the side of the frame and out through the Bracket. Secure the Bolt Plate to the Bracket with (2) 12mm Flat Washers, (2) 12mm Lock Washers and (2) 12mm Hex Nuts, **(Figure 6B)**. Snug but do not fully tighten hardware at this time. Repeat to install the 12mm x 35mm Single Bolt Plate, **(Figure 7A)**, in the remaining hole in the other side of the frame channel and Bracket, **(Figures 7B & 7C)**.



**Fig 6A**

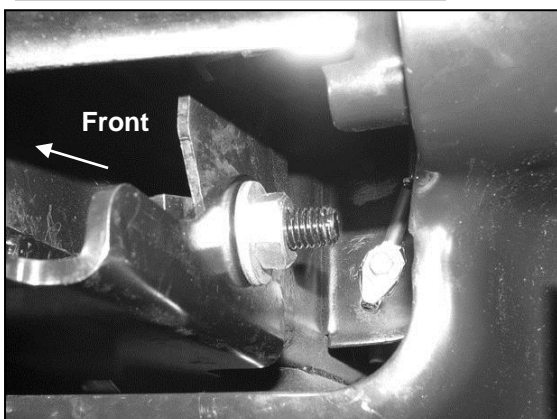


**(Fig 6B) Outer passenger side pictured**

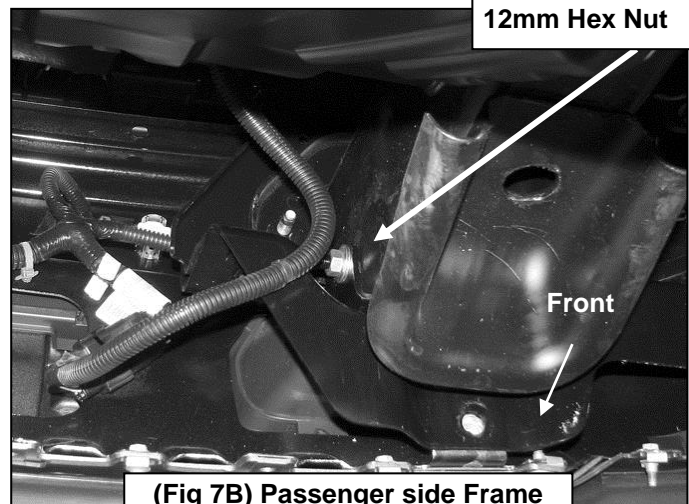


**Fig 7A**

**12mm Bolt Plate  
12mm Flat Washer  
12mm Lock Washer  
12mm Hex Nut**

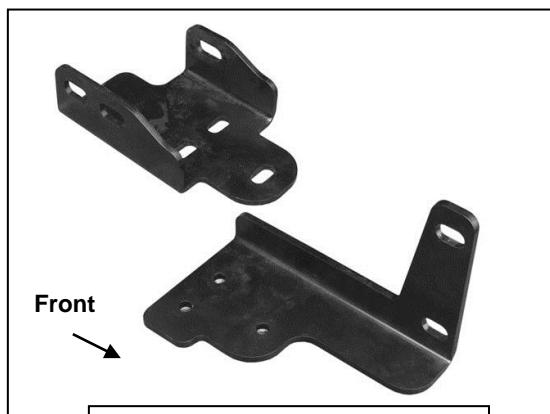


**(Fig 7C) Driver side Bracket installation pictured from front**



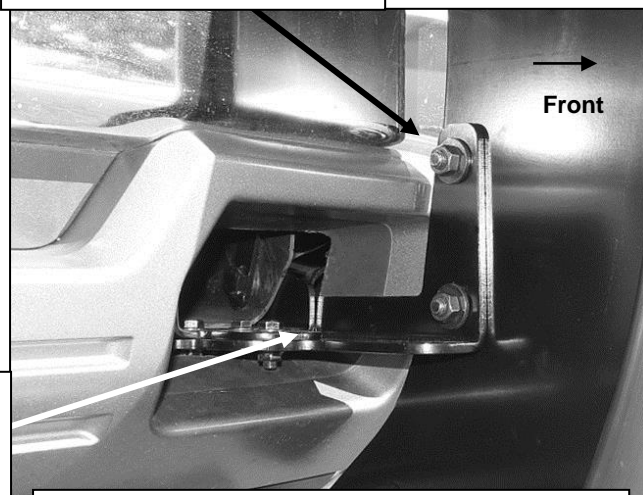
**(Fig 7B) Passenger side Frame Bracket installation pictured**

4. Next, select the driver side Mounting Bracket. Bolt the Mounting Bracket to the bottom of the Frame Bracket with (3) 8mm x 25mm Hex Bolts, (3) 8mm Lock Washers and (3) 8mm Flat Washers, **(Figures 8 & 9)**. Do not tighten hardware at this time.



**(Fig 8) Driver side Mounting Brackets pictured**

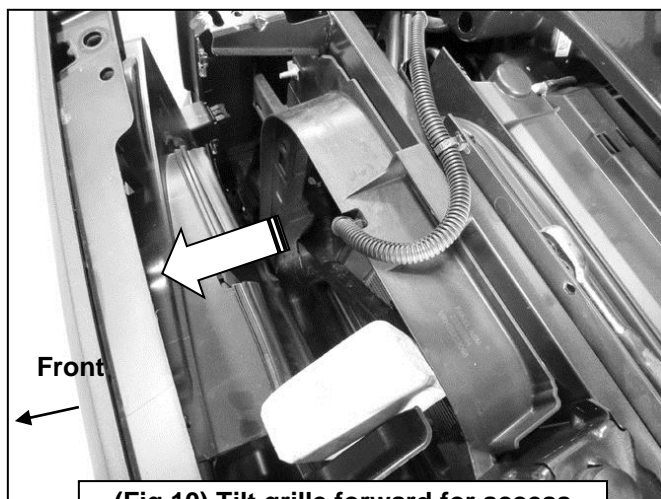
(2) 10mm x 30mm Hex Bolts  
(4) 10mm Flat Washers  
(2) 10mm Lock Washers  
(2) 10mm Hex Nuts



**(Fig 9) Driver side pictured with Grille Guard**

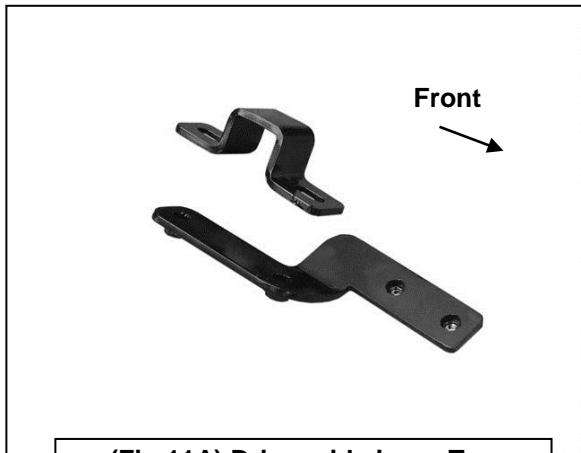
**Bolt the Mounting Bracket to the bottom of the Frame Bracket with:**  
(3) 8mm 25mm Hex Bolts  
(3) 8mm Lock Washers  
(3) 8mm Flat Washers

5. Repeat **Steps 2—4** to install the passenger side Frame and Mounting Brackets
6. Next, open the hood and remove the plastic cover between the top of the grille and the radiator, **(Figure 10)**. Use a small flat blade screw driver to pop up the center of the plastic clips. Locate and remove the hardware bolting the top of the grille in place. Carefully pull the grille straight out from the vehicle to release the grille from the clips and tilt forward, **(Figure 10)**. **IMPORTANT:** It is not necessary to completely remove the grille, just make sure all hardware has been removed before pulling on grille to release from clips. **NOTE:** On some models, Top Brackets can be installed through the openings in the grille without removing or releasing the grille.



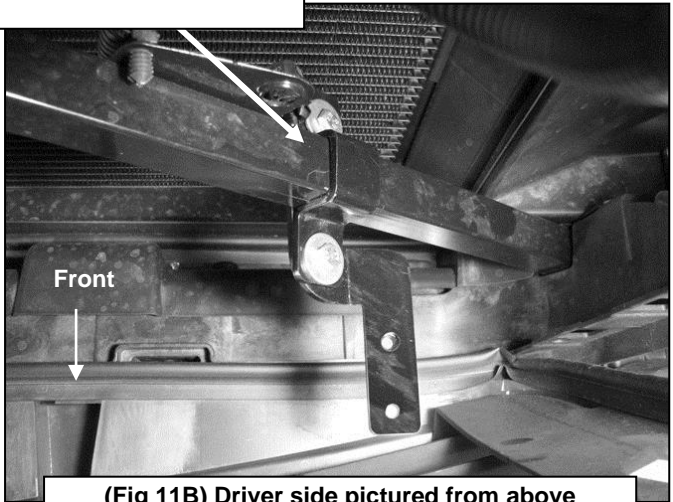
**(Fig 10) Tilt grille forward for access**

7. Locate the square tube support braces between the grille and the radiator running up at an angle from the top of the frame channel to the bottom of the hood release mechanism, **(Figures 11B, 13 & 14)**. Select the driver side Inner Top Bracket and (1) Backing Plate, **(Figure 11A)**. Hold the Inner Bracket up to the bottom of the brace tube with the Backing Plate over the top. Bolt the Brackets together around the square tube with (2) 6mm x 25mm Hex Bolts, (2) 6mm Lock Washers and (2) 6mm Flat Washers, **(Figure 11B)**. Leave loose at this time.



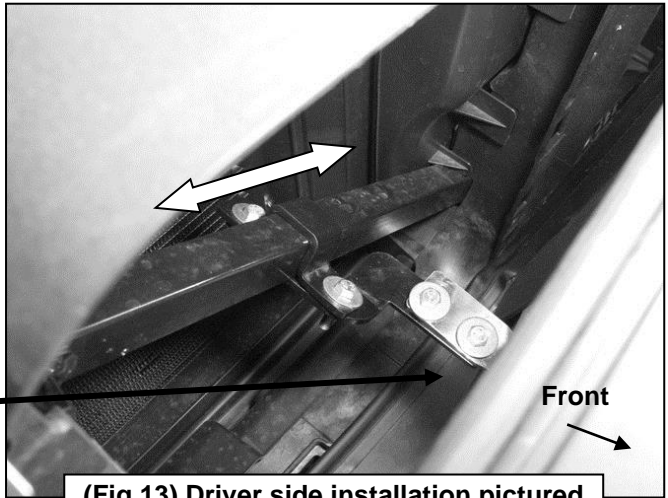
**(Fig 11A) Driver side inner Top Bracket and Backing Plate pictured**

**Bolt the Top Inner Bracket to the Backing Plate with:**  
**(2) 6mm x 25mm Hex Bolts**  
**(2) 6mm Lock Washers**  
**(2) 6mm Flat Washers**

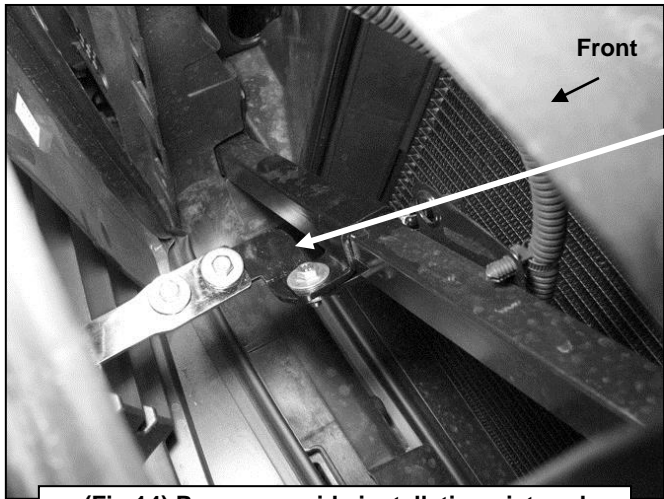


**(Fig 11B) Driver side pictured from above**

**Driver side Top Bracket installation pictured. Adjust position up or down the square tubing so that Bracket cannot come in contact with plastic grille**



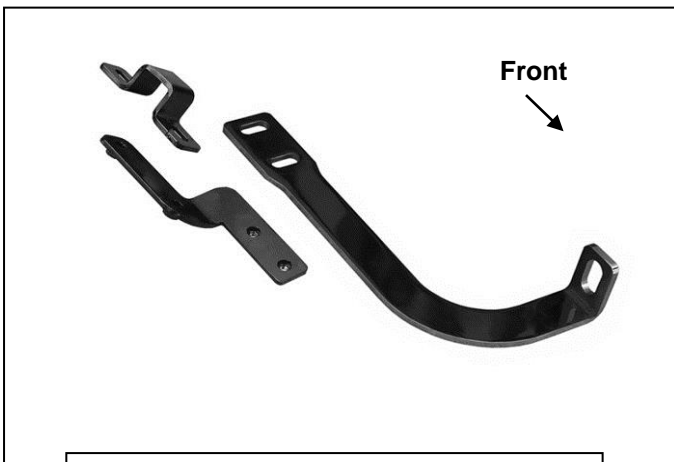
**(Fig 13) Driver side installation pictured**



**(Fig 14) Passenger side installation pictured**

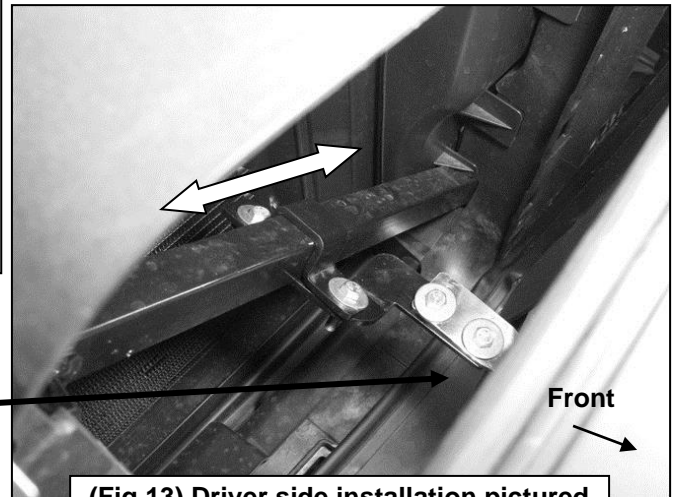
**Bolt the Top Outer Bracket to the Inner Bracket with:**  
**(2) 6mm x 25mm Hex Bolts**  
**(2) 6mm Lock Washers**  
**(2) 6mm Flat Washers**

8. Select the driver side Outer Top Bracket, **(Figure 12)**. Insert the Outer Bracket through the grille and up to the Inner Top Bracket assembly, **(Figure 13)**. Slide the Bracket assembly up or down the tube to match up with the Outer Top Bracket. Bolt the Outer Bracket to the top of the Inner Bracket with (2) 6mm x 25mm Hex Bolts, (2) 6mm Lock Washers and (2) 6mm Flat Washers, **(Figures 13—15)**. Leave all hardware loose at this time.



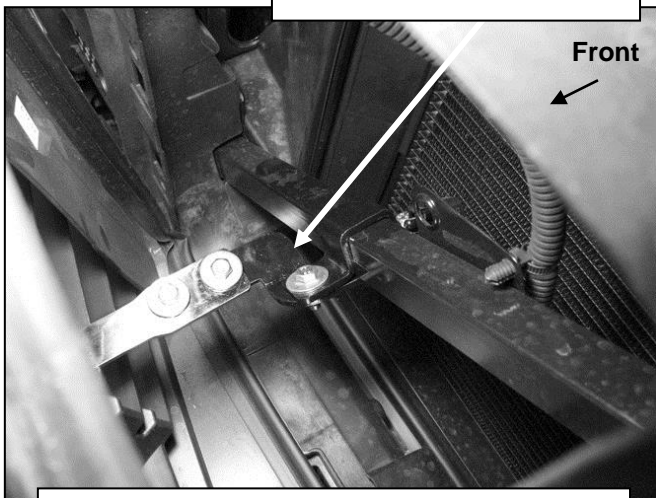
**(Fig 12) Driver side Top Brackets**

Driver side Top Bracket installation pictured. Adjust position up or down the square tubing so that Bracket cannot come in contact with plastic grille

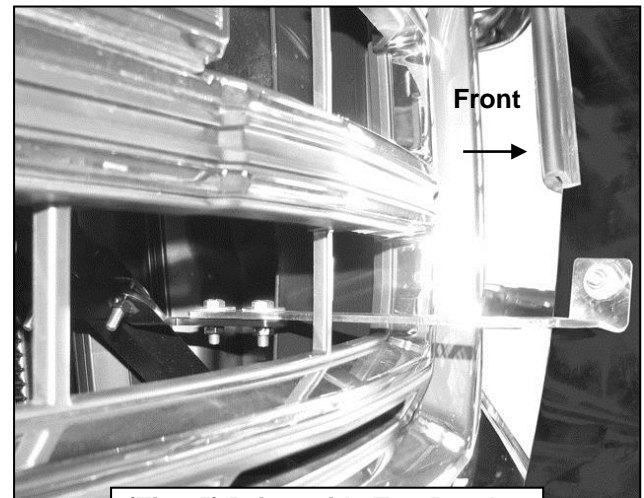


**(Fig 13) Driver side installation pictured**

Bolt the Top Outer Bracket to the Inner Bracket with:  
 (2) 6mm x 25mm Hex Bolts  
 (2) 6mm Lock Washers  
 (2) 6mm Flat Washers

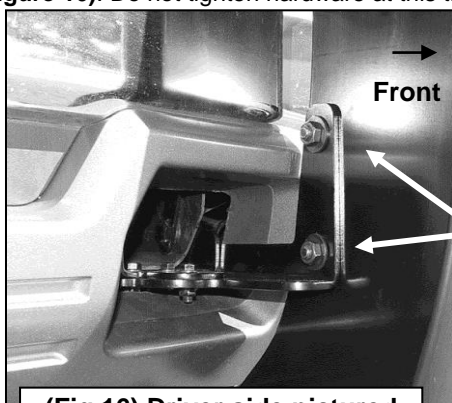


**(Fig 14) Passenger side installation pictured**



**(Fig 15) Driver side Top Bracket installation pictured**

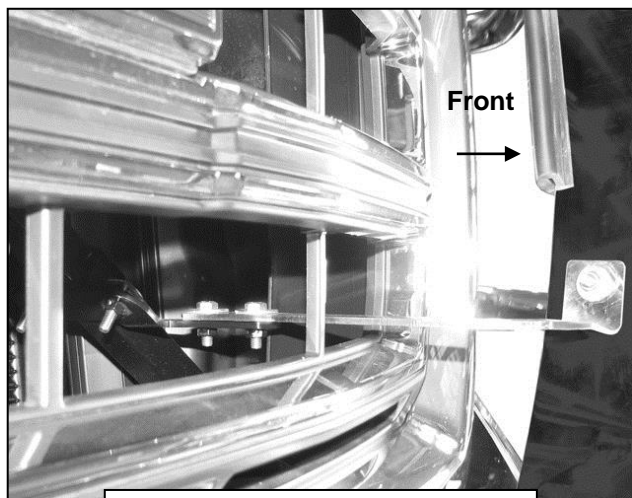
9. Repeat **Steps 7 & 8** for passenger side Top Bracket assembly installation, **(Figure 14)**.
10. With assistance, hold the Grille Guard up in position on the outside of the Mounting Brackets. Bolt the Grille Guard to the Brackets with (4) 10mm x 30mm Hex Bolts, (8) 10mm Flat Washers, (4) 10mm Lock Washers and (4) 10mm Hex Nuts, **(Figure 16)**. Do not tighten hardware at this time.



**(Fig 16) Driver side pictured**

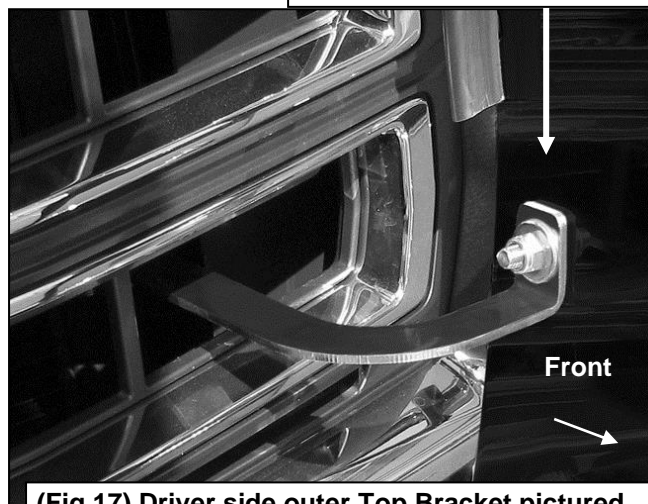
(2) 10mm x 30mm Hex Bolts  
 (4) 10mm Flat Washers  
 (2) 10mm Lock Washers  
 (2) 10mm Hex Nuts

11. Check the Grille guard side-to-side alignment with the vehicle. Adjust as required then tighten only the (6) 8mm Hex Bolts securing the Mounting Brackets to the bottom of the Frame Brackets. Do not fully tighten the Grille Guard to Bracket hardware at this time.
12. Line up the outer bent end of the driver side Top Bracket with the hole in the Grille Guard upright. Bolt the Top Bracket to the upright with (1) 8mm x 25mm Button Head Allen Bolt, (2) 8mm Flat Washers and (1) 8mm Nylon Lock Nut, (**Figures 15 & 17**). **NOTE:** It may be necessary to loosen and slide the Inner Top Bracket assembly up or down to properly match up the Outer Top Bracket with the hole in the upright on the Grille Guard.



(Fig 15) Driver side Top Bracket installation pictured

(1) 8mm Button Head Bolt  
(2) 8mm Flat Washers  
(1) 8mm Nylon Lock Nut



(Fig 17) Driver side outer Top Bracket pictured

13. Repeat **Step 12** for passenger side Top Bracket installation.
14. Level and adjust the Grille Guard and fully tighten all hardware including bumper, bumper bracket and all Grille Guard Bracket hardware. **IMPORTANT:** Adjust the position of the Top Brackets so that they cannot come in contact with the plastic grille, (**Figures 13—15 & 17**).
15. Reattach the plastic grille and top plastic cover if loosened.
16. Do periodic inspections to the installation to make sure that all hardware is secure and tight.





**PRODUCT CARE**

- Periodically check the product to ensure all fasteners are tight and components are intact.
- Regular waxing is recommended to protect the finish of the product.
- **Use ONLY Non-Abrasive automotive wax.** Use of any soap, polish or wax that contains an abrasive is detrimental and can scratch the finish leading to corrosion.
- Aluminum polish may be used to polish small scratches and scuffs for **Stainless Steel finish.**
- Mild soap may be used to clean the product for both **Stainless Steel and Black finish.**

**FAQ's****1. Hardware's are not of correct size.**

*In GMC / Chevrolet truck model 2006 & up, customer needs to reuse the factory body bolts to install the bracket. If your vehicle is not GMC / Chevrolet 2006 & up, ensure that holes are not partially covered with any plastic grommet or rust? If it is, remove the plastic grommet & rust from the thread holes & re-try the installation.*

**2. Mounting Bracket are not getting Installed properly.**

*In some cases Illustration images shown in Installation manual may not be the exactly same as per actual vehicle images ,also if Driver / Passenger side mounting brackets are very identical in the design, suggest referring Parts Identification guide to avoid fitment issue.*

**3. Products are thumping / rattling after installation.**

*Ensure that all required mounting brackets / hardware's are installed & tighten correctly. Suggest using white lithium / regular grease between the metal to metal contact surfaces.*

**4. Side Bar is not aligning with vehicle / Step Pads are not aligning with vehicle doors.**

*Side bar may be interchanged or mounting brackets are not installed at the correct position in the vehicle. Refer Parts identification guide.*

**5. Missing / Excess Hardware.**

*Recheck hardware count as per the part list.*

**6. Product not installing properly.**

*Ensure make model year, cab length and bed size of your vehicle is listed in the application. All installation steps are followed correctly.*

**Check out these other TrailFX Products!!**

www.TrailFX.com



*Keystone Automotive Operations Inc. (KAO) warrants this product to be free of defects in material and workmanship at the time of purchase by the original retail consumer. KAO disclaims any other warranties, express or implied, including the warranty of fitness for a particular purpose or an intended use. If the product is found to be defective, KAO may replace or repair the product at our option, when the product is returned prepaid, with proof of purchase. Alteration to, improper installation, or misuse of this product voids the warranty. KAO's liability is limited to repair or replacement of products found to be defective, and specifically excludes liability for any incidental or consequential loss or damage.*