

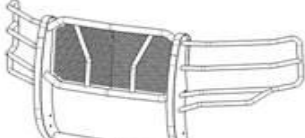







	<h2 style="margin:0;">Extreme Grille Guard</h2> <h3 style="margin:0;">Part No. E0511B</h3>	
--	--	---

Fits: 2017-Current Ford 250 /350 /450/ 550 Super Duty

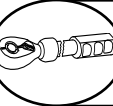
<div style="margin-bottom: 10px;">  </div> <div style="margin-bottom: 10px;">  <p>REMOVE CONTENTS FROM BOX. VERIFY ALL PARTS ARE PRESENT.</p> </div> <div style="margin-bottom: 10px;">  <p>READ INSTRUCTIONS CAREFULLY BEFORE STARTING INSTALLATION.</p> </div> <div>  <p>DO NOT OVER TORQUE. STANDARD OPERATING LOAD FOR TIGHTEN BODY MOUNT NUTS & BOLTS VARIES FROM 45 TO 65 FOOT POUND.</p> </div>	<div style="margin-bottom: 10px;">  <p>60-180 min</p> </div> <div style="margin-bottom: 10px;">  <p>CUTTING May Be REQUIRED</p> </div> <div style="margin-bottom: 10px;">  <p>DRILLING NOT REQUIRED</p> </div> <div style="margin-bottom: 10px;">  <p>support@trailfx.com</p> </div> <div style="margin-bottom: 10px;">  <p>1 866 638 4870</p> </div> <div>  <p>WARRANTY POLISHED STAINLESS STEEL – LIMITED LIFETIME POWDER COATED BLACK – 3 YEARS</p> </div>
--	--

PARTS LIST:

Qty	Part Description	Qty	Part Description
1	Grille Guard	2	12mm Plastic Retainers
1	Driver/Left Frame Mounting Bracket	8	12-1.75mm x 35mm Hex Bolts
1	Passenger/Right Frame Mounting Bracket	16	12mm x 32mm OD x 3mm Flat Washers
2	Spacer Plates (2017-19 models only)	8	12mm Lock Washers
1	Driver/Left Lower Mounting Bracket	8	12mm Hex Nuts
1	Passenger/Right Lower Mounting Bracket	1	2.5mm Wrench

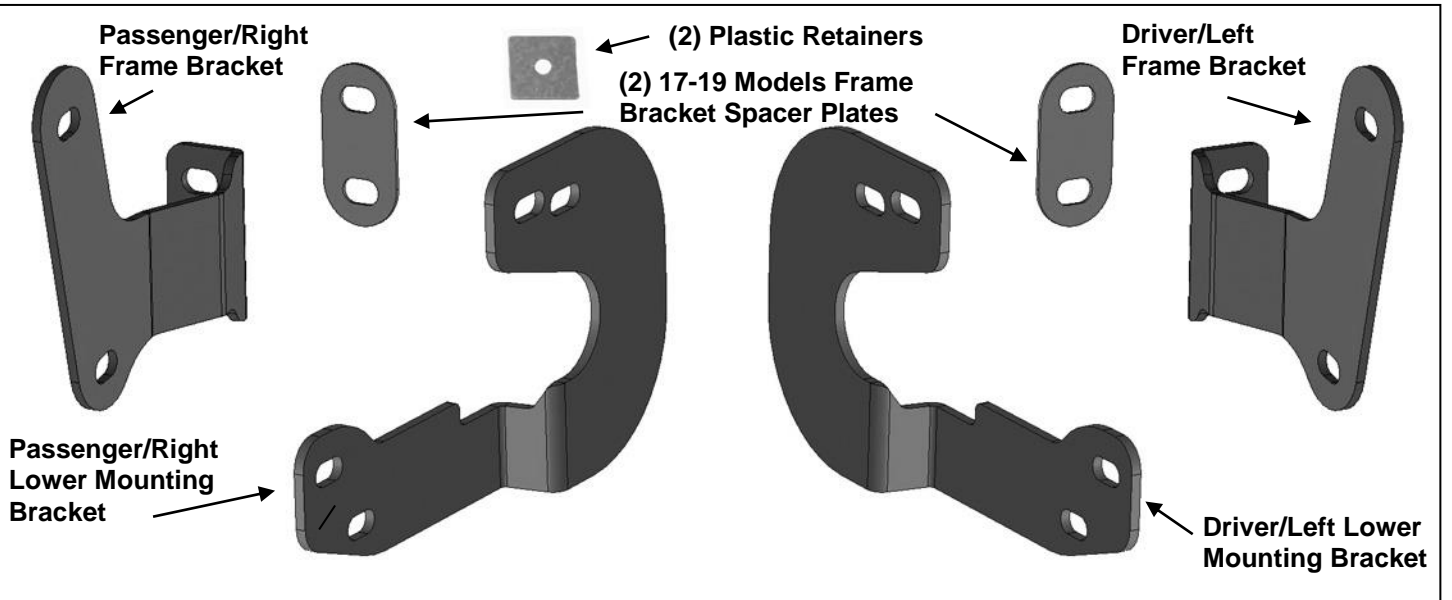

PROCEDURE:

REMOVE CONTENTS FROM BOX. VERIFY ALL PARTS ARE PRESENT. READ INSTRUCTIONS CAREFULLY BEFORE STARTING INSTALLATION. ASSISTANCE IS RECOMMENDED TO AVOID POSSIBLE INJURY OR DAMAGE TO THE VEHICLE. CUTTING IS REQUIRED.

- Starting at the front-driver side of the front bumper, remove the plastic cover, (if equipped), covering the bumper bolts on both sides of the tow hook, **(Figure 1)**. Remove the (2) outer bumper bolts, **(Figures 2 & 3)**. **IMPORTANT:** Do not remove the inner bumper bolts or the bumper may fall. Only remove the outer bumper bolts. **NOTE:** Cover cannot be reinstalled.

2. Select the driver side Frame Bracket. Determine procedure for your model year.
 - 2017-19 models only:**
 - a. Select (1) Spacer Plate, **(Figure 4)**. Place the Spacer over the holes for the bumper bolts, between the bumper and the Bracket.
 - b. Reuse the factory bumper bolts to attach the Frame Bracket to the Spacer and bumper, **(Figure 5)**.
 - 2020 models only:**
 - a. Reuse the factory bumper bolts to attach the Frame Bracket to the bumper, note no Spacers are required, **(Figure 5)**.
3. Make sure there is clearance between the top and bottom of the Frame Bracket and the opening in the bumper. Do not tighten hardware at this time.
4. Repeat **Steps 1—3** for passenger side Frame Bracket and Spacer installation.
5. Next, remove the plastic air dam from the bottom of the bumper and place it on a clean, stable work surface, **(Figure 6)**. Note the location and type of all factory hardware for reinstallation.
6. From under the driver side of the bumper, locate the (2) outer hex nuts attaching the frame extension to the outside of the frame, **(Figure 7)**. Remove (1) of the (2) factory hex nuts, **(Figures 8 & 9)**. Thread (1) Plastic Retainer onto the threaded end of the double bolt plate inside the frame. Remove the second factory nut from the bolt plate. **NOTE:** The Plastic Retainer is designed to help hold the factory double bolt plate in place in the frame and to help with bracket installation. Do not allow the double bolt plate to fall into the frame channel.
7. Select the driver side Lower Mounting Bracket. Reuse the (2) factory hex nuts to attach the Bracket to the double bolt plate, **(Figure 10)**. Do not tighten hardware at this time.
8. Repeat **Steps 5 & 6** for passenger side Lower Mounting Bracket installation.
9. With assistance, position the Grille Guard up to the outside of the Mounting Brackets. Attach the Grille Guard to the Frame Brackets with the included (4) 12mm x 35mm Hex Bolts, (8) 12mm Flat Washers, (4) 12mm Lock Washers and (4) 12mm Hex Nuts, **(Figure 11)**. Do not fully tighten hardware.
10. Attach the Grille Guard to the Lower Mounting Brackets with the included (4) 12mm x 35mm Hex Bolts, (8) 12mm Flat Washers, (4) 12mm Lock Washers and (4) 12mm Hex Nuts, **(Figure 11)**. Do not tighten hardware at this time.
11. Level and adjust the Grille Guard and fully tighten the Bracket to vehicle hardware only at this time. Temporarily remove the Grille Guard.
12. Hold the plastic air dam up in position against the Lower Brackets and mark the location of the Brackets onto the top of the air dam, **(Figure 12)**. Measure the location of the Lower Brackets and transfer these measurements onto the back of the air dam, **(Figures 13 & 14)**. Place the air dam back up to the (2) Lower Mounting Brackets to verify location before cutting. Check all measurements on the vehicle. Once absolutely satisfied, use a hacksaw blade or utility knife to carefully cut (2) openings in air dam. Check fit, trim as necessary and reuse the factory hardware to reinstall air dam over Lower Brackets. **IMPORTANT:** On the “tall” air dam only, do not cut through the top or bottom edge of the air dam, **(Figure 13)**. **NOTE:** It may be necessary to loosen or temporarily remove the Lower Mounting Brackets only to reinstall the air dam.
13. Reinstall the Lower Brackets through the air dam if removed.
14. Reinstall the Grille Guard as described in **Steps 8 & 9**. Level and adjust Grille Guard and fully tighten all hardware. Reinstall the license plate and bracket.
15. On models with grille mounted camera, use included 2.5mm Wrench to remove center screen from Grille Guard, **(Figure 15)**.
16. Do periodic inspections to the installation to make sure that all hardware is secure and tight.

To protect your investment, wax this product after installing. Regular waxing is recommended to add a protective layer over the finish. Do not use any type of polish or wax that may contain abrasives that could damage the finish.

For gloss black finishes: Mild soap may be used to clean the Grille Guard.

Driver/left Side Installation Pictured



(Fig 1) Remove cover over bumper bolts (2017-19 model year pictured)

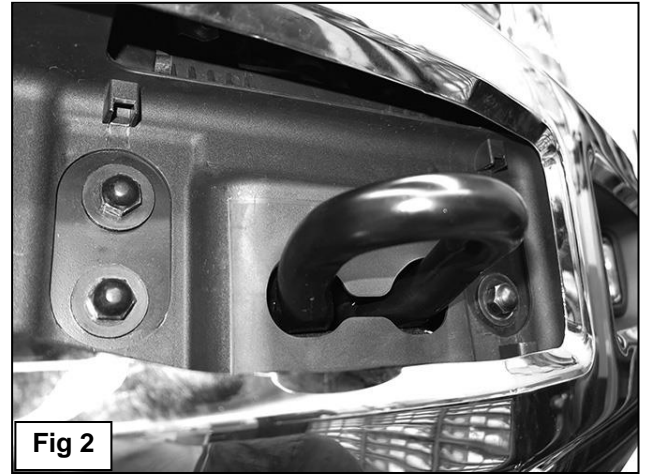
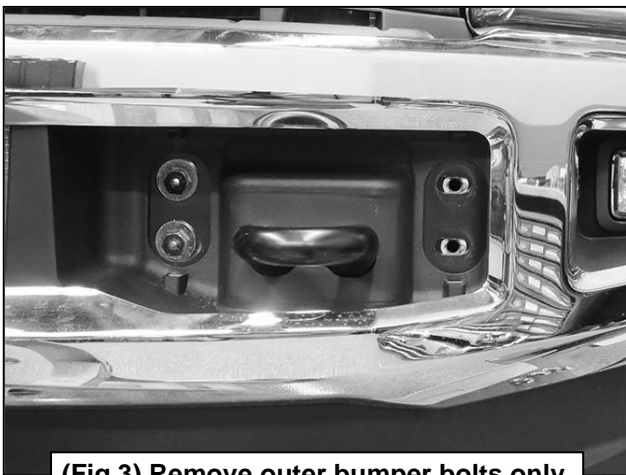
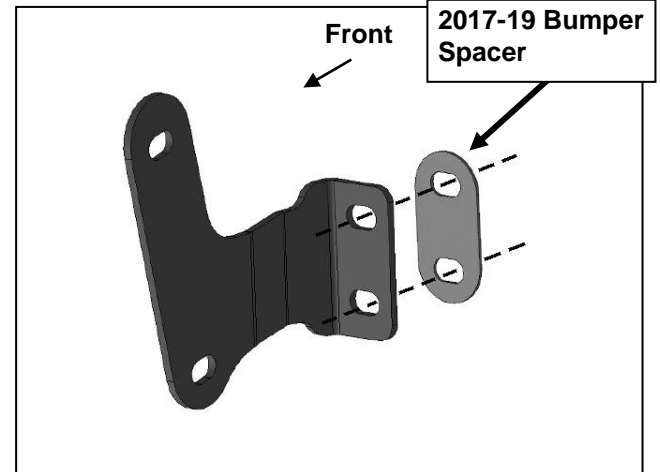

Fig 2

Driver/left Side Installation Pictured



(Fig 3) Remove outer bumper bolts only



(Fig 4) On 2017-19 models only, attach driver/left Frame Bracket to Spacer and bumper. Do not install Bracket without Spacer on 2017-19 model years



(Fig 5) Reuse factory bumper bolts to attach driver/left Frame Bracket to bumper



(Fig 6) Remove plastic air dam from bumper



(Fig 7) Driver/left frame extension pictured

Driver/left Side Installation Pictured

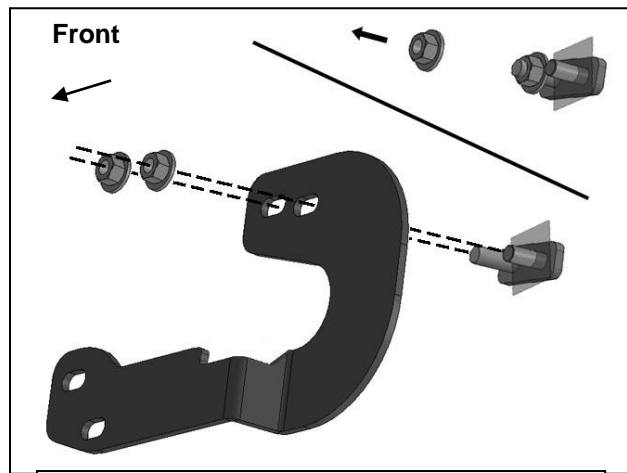

(Fig 8) Driver/left Lower Bracket illustrated. Reuse factory hardware to attach Bracket to side of frame and frame extension

Remove (1) nut, thread (1) 12mm Plastic Retainer onto threaded end before removing remaining hex nut

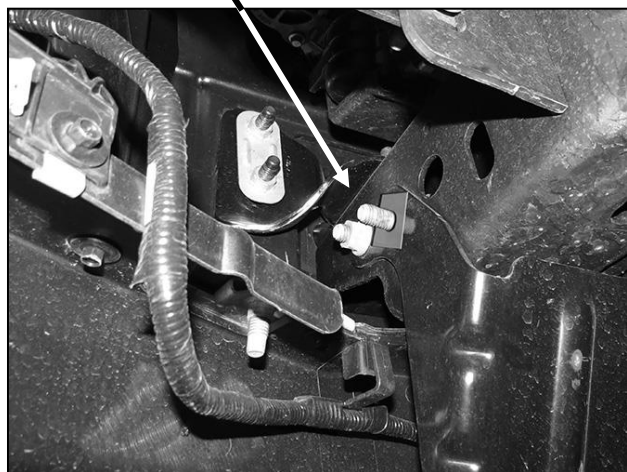

(Fig 9) Driver/left frame extension pictured

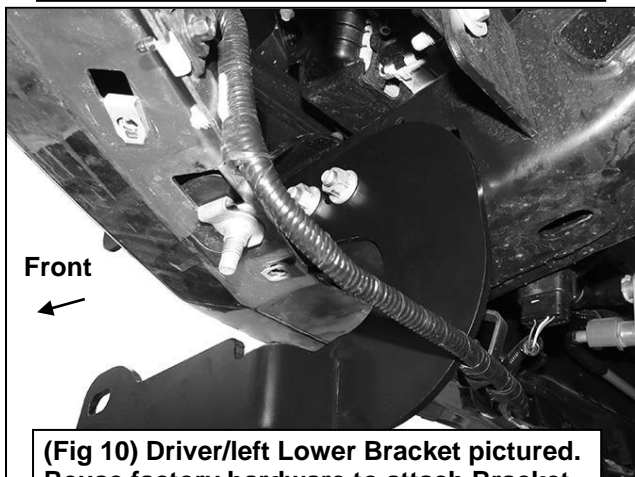

(Fig 10) Driver/left Lower Bracket pictured. Reuse factory hardware to attach Bracket to side of frame and frame extension

- (4) 12mm x 35mm Hex Bolts
- (8) 12mm Flat Washers
- (4) 12mm Lock Washers
- (4) 12mm Hex Nuts

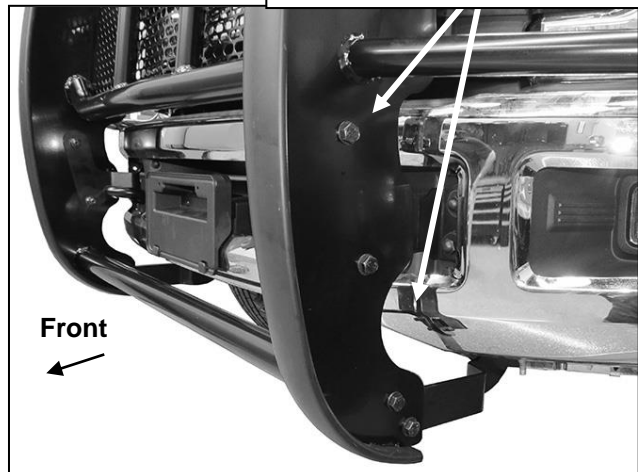
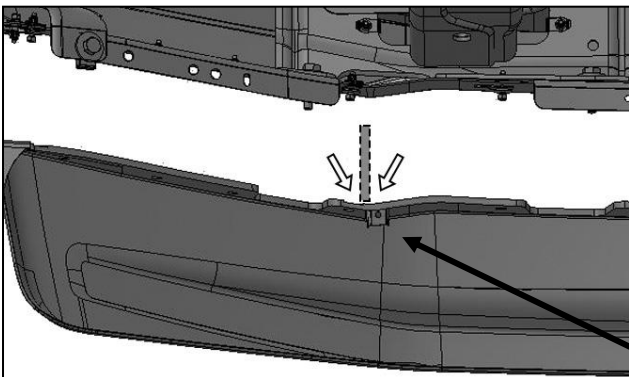
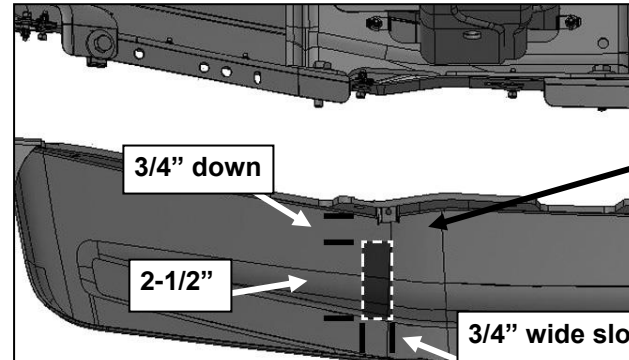

Fig 11



Hold air dam up against bottom of Brackets (dashed line for reference). Mark location of Bracket onto top of air dam (arrows)

(Fig 12) Driver side-back of air dam illustrated



Do not cut through the top or bottom edges of the "tall" air dam. Only remove enough material to clear the Brackets

(Fig 13) Driver side-back of "tall" STD air dam illustrated. All measurements are for reference and example only, check all measurements before cutting air dam.

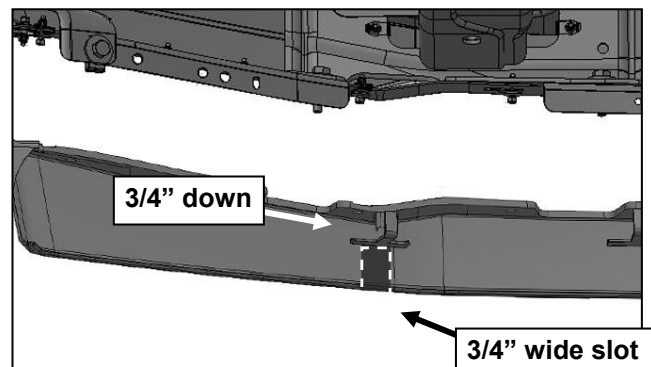

(Fig 14) Driver side-back of "short" air dam illustrated. All measurements are for reference and example only, check all measurements before cutting air dam.

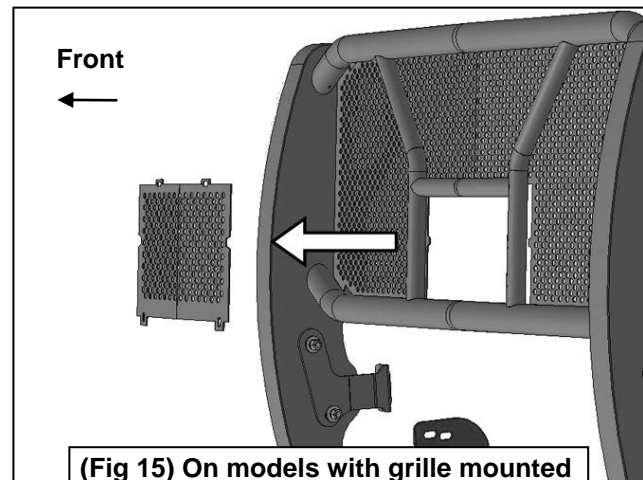

(Fig 15) On models with grille mounted camera, remove center screen



No.	Parts Identification
1	Passenger / Right 'Rear' Bracket marked "PR"
2	Driver / Left 'Rear' Bracket marked "DR"
3	Passenger / Right 'Center' Bracket marked "PC"
4	Driver / Left 'Center' Bracket marked "DC"
5	Passenger / Right 'Front' Bracket marked "PF"
6	Driver / Left 'Front' Bracket marked "DF"

Note:

- This guide is to identify the parts and not a reference for part count.
- For part count, refer Parts List.
- Product / Bracket image is representative and actual design may vary.

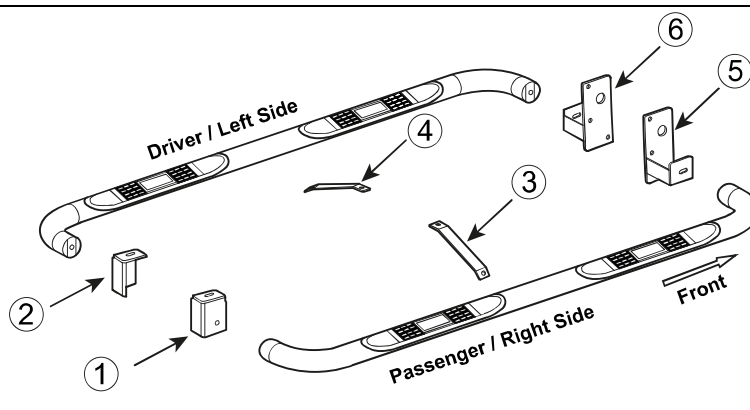
**PRODUCT CARE**

- Periodically check the product to ensure all fasteners are tight and components are intact.
- Regular waxing is recommended to protect the finish of the product.
- **Use ONLY Non-Abrasive automotive wax.** Use of any soap, polish or wax that contains an abrasive is detrimental and can scratch the finish leading to corrosion.
- Aluminum polish may be used to polish small scratches and scuffs for **Stainless Steel finish.**
- Mild soap may be used to clean the product for both **Stainless Steel and Black finish.**

FAQ's**1. Hardware's are not of correct size.**

In GMC / Chevrolet truck model 2006 & up, customer needs to reuse the factory body bolts to install the bracket. If your vehicle is not GMC / Chevrolet 2006 & up, ensure that holes are not partially covered with any plastic grommet or rust? If it is, remove the plastic grommet & rust from the thread holes & re-try the installation.

2. Mounting Bracket are not getting Installed properly.

In some cases Illustration images shown in Installation manual may not be the exactly same as per actual vehicle images ,also if Driver / Passenger side mounting brackets are very identical in the design, suggest referring Parts Identification guide to avoid fitment issue.

3. Products are thumping / rattling after installation.

Ensure that all required mounting brackets / hardware's are installed & tighten correctly. Suggest using white lithium / regular grease between the metal to metal contact surfaces.

4. Side Bar is not aligning with vehicle / Step Pads are not aligning with vehicle doors.

Side bar may be interchanged or mounting brackets are not installed at the correct position in the vehicle. Refer Parts identification guide.

5. Missing / Excess Hardware.

Recheck hardware count as per the part list.

6. Product not installing properly.

Ensure make model year, cab length and bed size of your vehicle is listed in the application. All installation steps are followed correctly.

Check out these other TrailFX Products!!

www.TrailFX.com

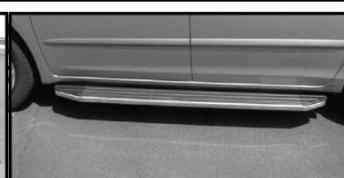
**BULL BAR****GRILLE GUARDS****BED RAILS****RUNNING BOARDS**

Keystone Automotive Operations Inc. (KAO) warrants this product to be free of defects in material and workmanship at the time of purchase by the original retail consumer. KAO disclaims any other warranties, express or implied, including the warranty of fitness for a particular purpose or an intended use. If the product is found to be defective, KAO may replace or repair the product at our option, when the product is returned prepaid, with proof of purchase. Alteration to, improper installation, or misuse of this product voids the warranty. KAO's liability is limited to repair or replacement of products found to be defective, and specifically excludes liability for any incidental or consequential loss or damage.