

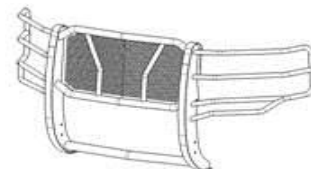

# Extreme Grille Guard

Part No. E0512B



Fits: 2014-Current Chevrolet Silverado 1500



ASSISTANCE IS RECOMMENDED.



REMOVE CONTENTS FROM BOX. VERIFY ALL PARTS ARE PRESENT.



READ INSTRUCTIONS CAREFULLY BEFORE STARTING INSTALLATION.

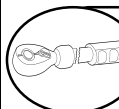

DO NOT OVER TORQUE. STANDARD OPERATING LOAD FOR TIGHTEN BODY MOUNT NUTS & BOLTS VARIES FROM 45 TO 65 FOOT POUND.



60-180 min



Cutting Required



Drilling Not Required



support@trailfx.com



1 866 638 4870



**WARRANTY** POLISHED STAINLESS STEEL – LIMITED LIFETIME  
POWDER COATED BLACK – 3 YEARS

### PARTS LIST:

Qty	Part Description	Qty	Part Description
1	Grille Guard Assembly	6	12mm x 24mm OD x 2.5mm Flat Washers
2	Frame Brackets	6	12mm Lock Washers
1	Driver/Left Mounting Bracket	6	12-1.75mm Hex Nuts
1	Passenger/Right Mounting Bracket	6	10-1.50mm x 30mm Hex Bolts
1	2014-15 Driver/Left Top Bracket	12	10mm x 27mm OD x 3mm Flat Washers
1	2014-15 Passenger/Right Top Bracket	6	10mm Lock Washers
1	2016-17 Driver/Left Top Bracket	6	10-1.50mm Hex Nuts
1	2016-17 Passenger/Right Top Bracket	6	8-1.25mm x 30mm Hex Bolts
2	12-1.75mm x 30mm Double Bolt Plates	6	8mm x 16mm OD x 1.6mm Flat Washers
2	12-1.75mm x 35mm Single Bolt Plates	6	8mm Lock Washers
		2	50mm x 250mm Adhesive Backed Foam Tapes

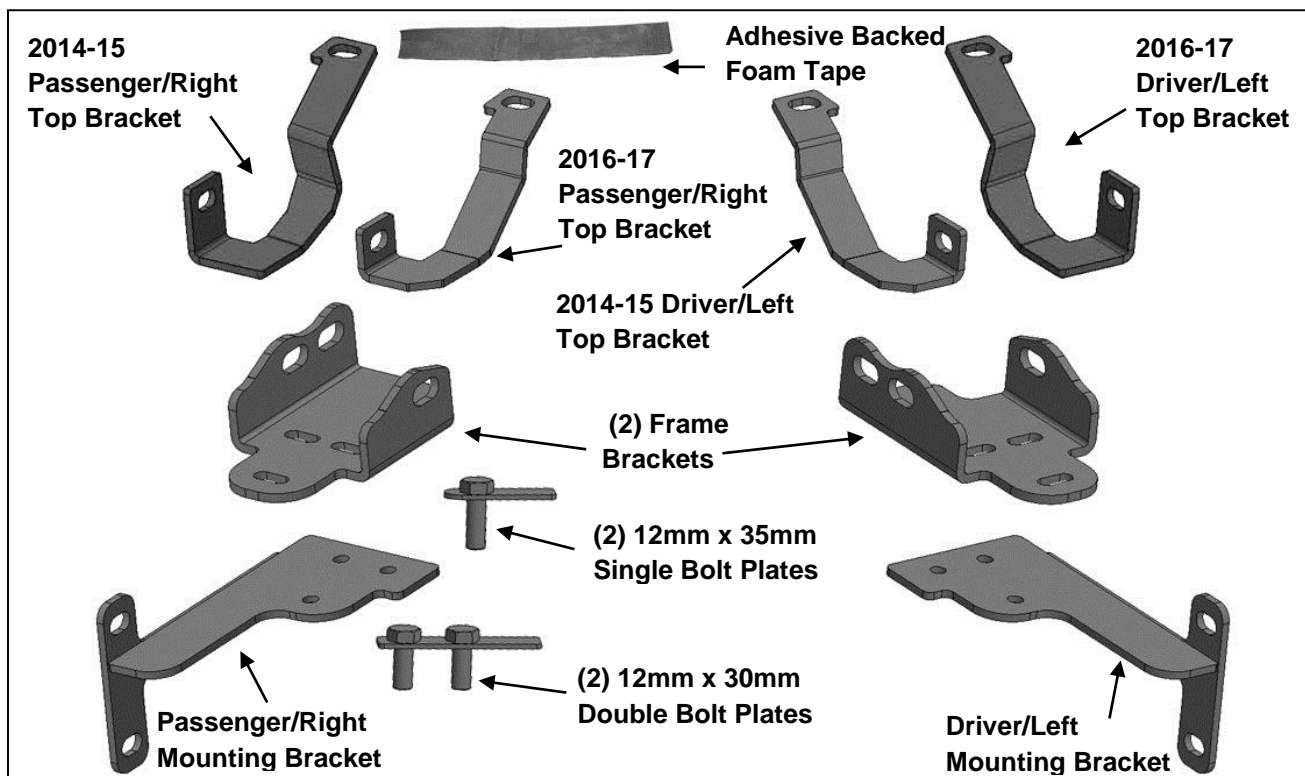

**INSTALLATION PROCEDURE:**

**REMOVE CONTENTS FROM BOX AND VERIFY ALL PARTS ARE PRESENT. READ INSTRUCTIONS CAREFULLY. CUTTING MAY BE REQUIRED. ASSISTANCE IS HIGHLY RECOMMENDED. INSTALLATION MAY INTERFERE WITH FRONT MOUNTED SENSORS.**

1. Open the hood and remove the cover between the top of the radiator and the grille, **(Figure 1)**. Remove the hardware attaching the grille at the top and bottom, **(Figure 2)**.
2. On **2014-15 models only**, from behind the bumper, release the clips and hardware to remove the plastic body panel, (fascia), on top of the bumper between the bottom of the grille and the top of the bumper, **(Figure 3)**. For **all models**, carefully remove the grille from the vehicle. **NOTE:** Grille is held in place with screws at the top and several clips, **(Figure 2)**. Remove the screws and firmly pull the grille straight out from the vehicle to release the grille from clips, **(Figures 4 & 5)**.
3. Remove the factory tow hooks and hardware if equipped. **IMPORTANT:** Tow hooks cannot be reinstalled with the Grille Guard. It is **not** necessary to remove the bumper, only loosen the hardware enough to rotate the bumper forward to remove the long hex bolts from the tow hooks, **(Figures 5 & 6)**.

**Vehicles without tow hooks:**

- a. Cut out the indented area in both sides of the plastic bumper insert to clear the Brackets as pictured, **(Figures 7 & 8)**. **IMPORTANT:** Make several small cuts for best fit. Do not cut through the top edge of the panel.
4. Select the driver side Frame Bracket, **(Figure 9)**. Insert the Frame Bracket through the opening in the bumper, **(Figure 10)**. Line up the holes in the Bracket with the holes in the end of the frame for the tow hook. Select (1) 12mm Double Bolt Plate, **(Figure 11)**. Insert the Double Bolt Plate into the end of the frame, through the (2) holes in the side of the frame and out through the Frame Bracket, **(Figure 12)**. Secure the Frame Bracket to the Bolt Plate with (2) 12mm Flat Washers, (2) 12mm Lock Washers and (2) 12mm Hex Nuts. Snug but do not fully tighten hardware at this time.
5. Select (1) 12mm Single Bolt Plate, **(Figure 13)**. Secure Frame Bracket to the Bolt Plate with (1) 12mm Flat Washer, (1) 12mm Lock Washer and (1) 12mm Hex Nut, **(Figure 14)**. Snug but do not tighten at this time.
6. Next, select the driver side Mounting Bracket, **(Figure 15)**. Attach the Mounting Bracket to the bottom of the Frame Bracket with (3) 8mm x 30mm Hex Bolts, (3) 8mm Lock Washers and (3) 8mm Flat Washers, **(Figures 15 & 16)**. Do not tighten hardware at this time.
7. Repeat **Steps 4—6** to install the passenger/right side Frame and Mounting Brackets.
8. Temporarily remove the driver/left side bumper bracket bolt, **(Figure 17)**. Depending on the year of the vehicle, select either the 2014-15 Driver/Left Top Bracket or the 2016-18 Driver/Left Top Bracket, **(Figure 18)**. Apply a layer of Adhesive Backed Foam Tape to the backside of the Top Bracket to protect the finish on the bumper. **IMPORTANT:** To prevent the Top Brackets from damaging the finish on the vehicle during installation, cover the top of the bumper with removable tape, (masking tape). Use the factory bumper bolt to attach the Top Bracket to the top of the bumper bracket, **(Figure 19)**. Leave hardware loose at this time. Repeat this Step to install the passenger/right side Top Support Bracket.
9. With assistance, hold the Grille Guard up in position on the outside of the Mounting Brackets. Attach the Grille Guard to the Brackets with (6) 10mm Hex Bolts, (12) 10mm Flat Washers, (6) 10mm Lock Washers and (6) 10mm Hex Nuts, **(Figures 20 & 21)**. Do not tighten hardware at this time.
10. Check the Grille guard alignment with the vehicle. Adjust as required then fully tighten the Bracket to vehicle hardware only. Do not fully tighten the Grille Guard to Bracket hardware at this time.
11. On 2014-15 models, reinstall the fascia body panel. On all models, reinstall the grille and top cover. Reinstall the Grille Guard. Level and adjust the Grille Guard and fully tighten all hardware.
12. Do periodic inspections to the installation to make sure that all hardware is secure and tight.

### Driver Side Mounting Bracket Installation Pictured



(Fig 1) Remove plastic cover from top of grille



(Fig 2) Remove cover between radiator and grille. Remove screws attaching top of grille (arrows)

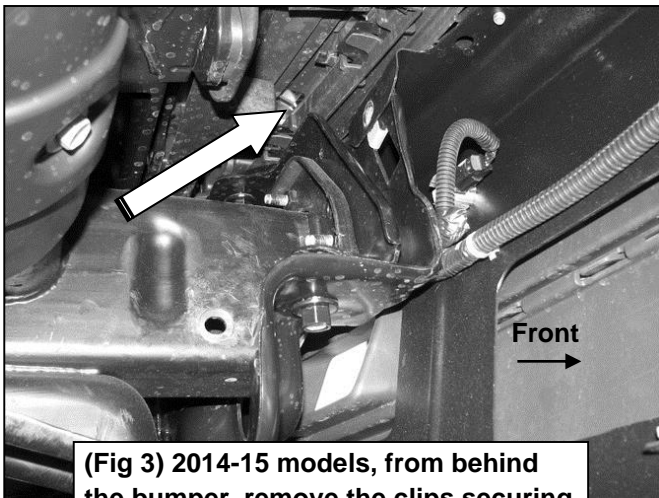

(Fig 3) 2014-15 models, from behind the bumper, remove the clips securing the fascia to the top of the bumper



(Fig 4) Firmly pull grille straight out from vehicle

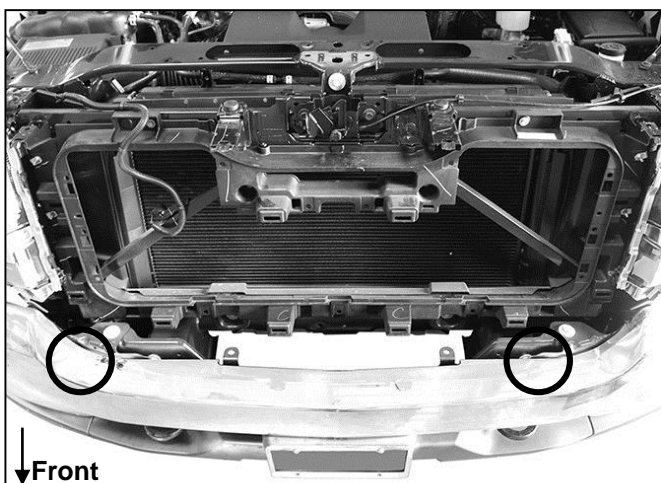

(Fig 5) Grille removed to access top bumper bolts

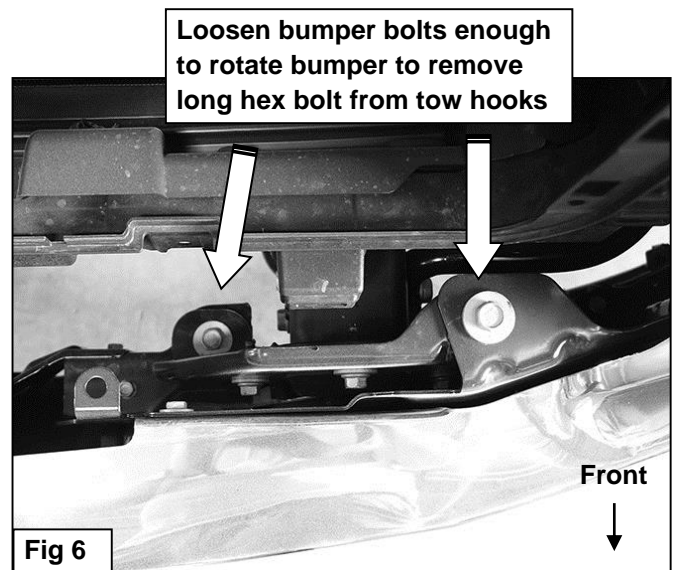
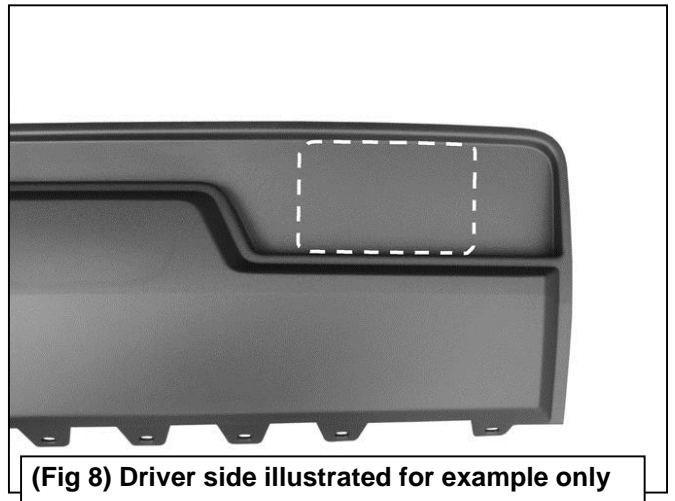

Fig 6

### Driver Side Mounting Bracket Installation Pictured



(Fig 7) "No tow hook" model pictured



(Fig 8) Driver side illustrated for example only

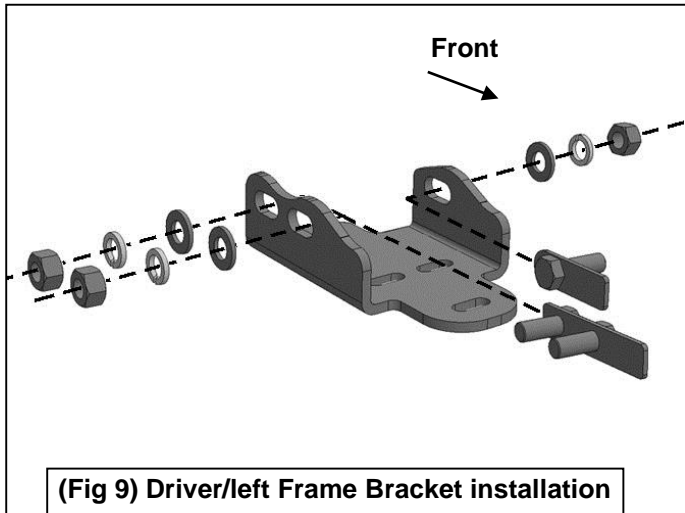

(Fig 9) Driver/left Frame Bracket installation

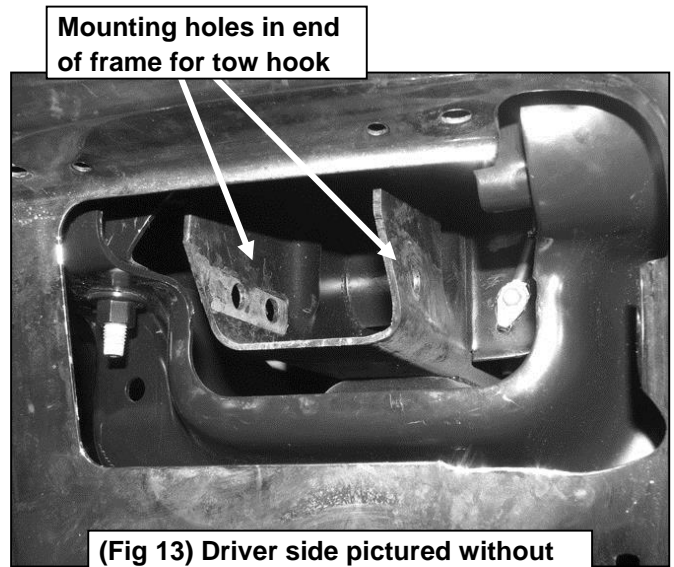

Mounting holes in end of frame for tow hook

(Fig 13) Driver side pictured without plastic panel for instruction purposes

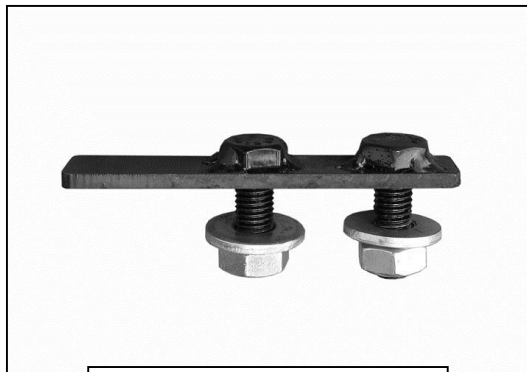

(Fig 11) Double Bolt Plate

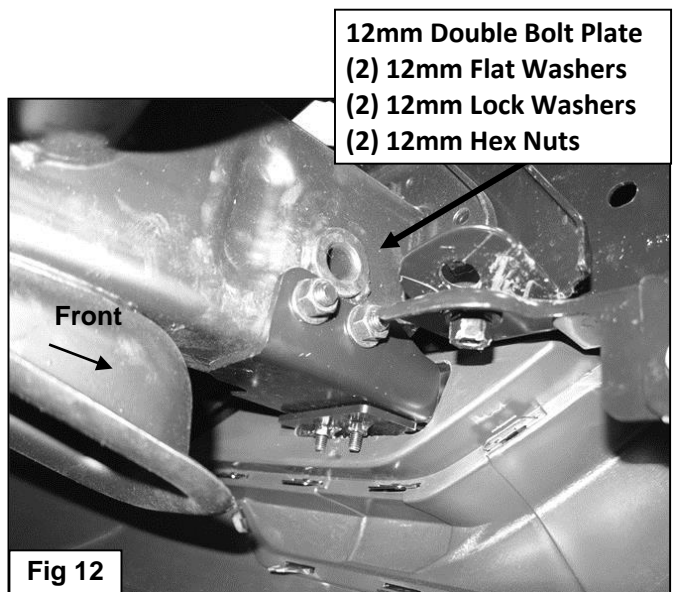

12mm Double Bolt Plate  
(2) 12mm Flat Washers  
(2) 12mm Lock Washers  
(2) 12mm Hex Nuts

Fig 12

### Driver Side Mounting Bracket Installation Pictured

- 12mm Bolt Plate
- 12mm Flat Washer
- 12mm Lock Washer
- 12mm Hex Nut

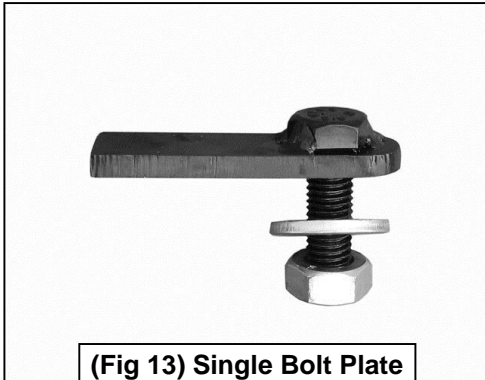

(Fig 13) Single Bolt Plate

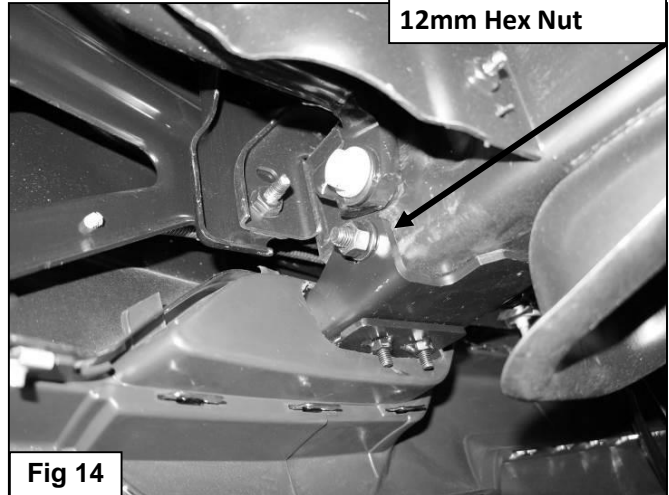
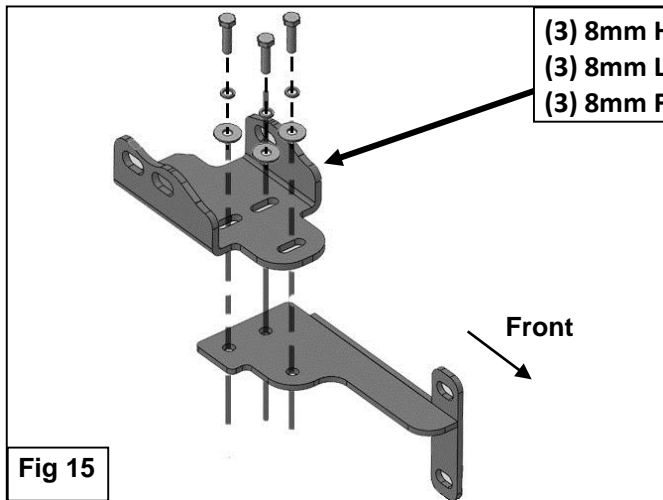

Fig 14



- (3) 8mm Hex Bolts
- (3) 8mm Lock Washers
- (3) 8mm Flat Washers

Front

Fig 15

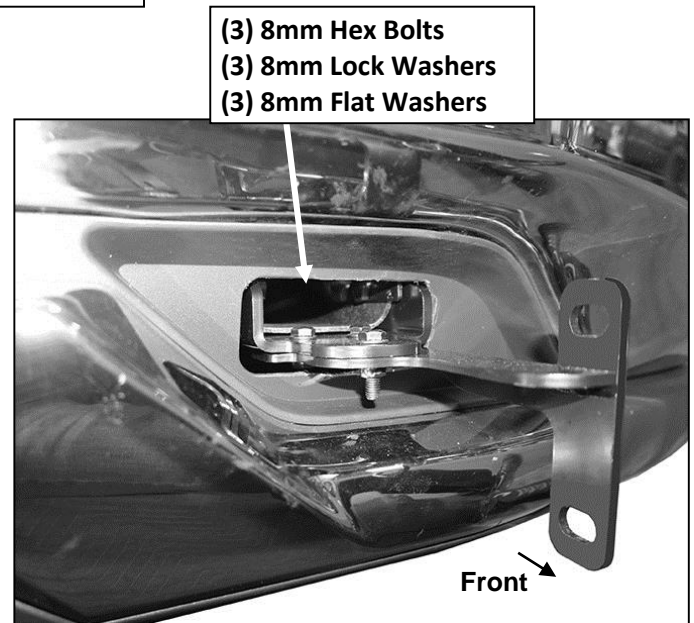

- (3) 8mm Hex Bolts
- (3) 8mm Lock Washers
- (3) 8mm Flat Washers

Front

(Fig 16) Driver side Bracket Installed

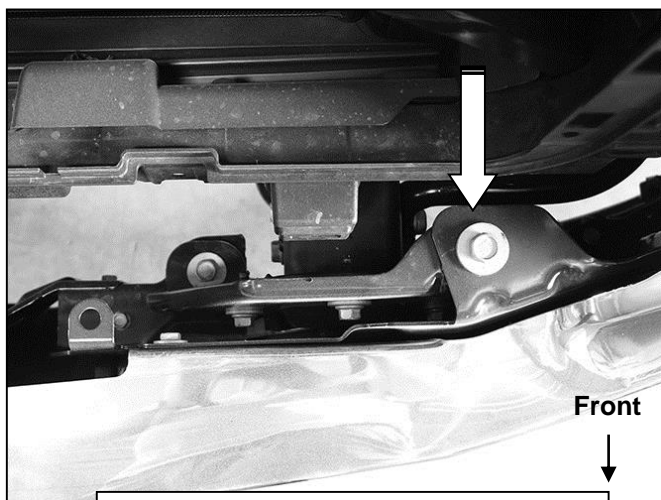

Front

(Fig 17) Top Mounting Bracket driver side mounting location from above



### Driver Side Mounting Bracket Installation Pictured

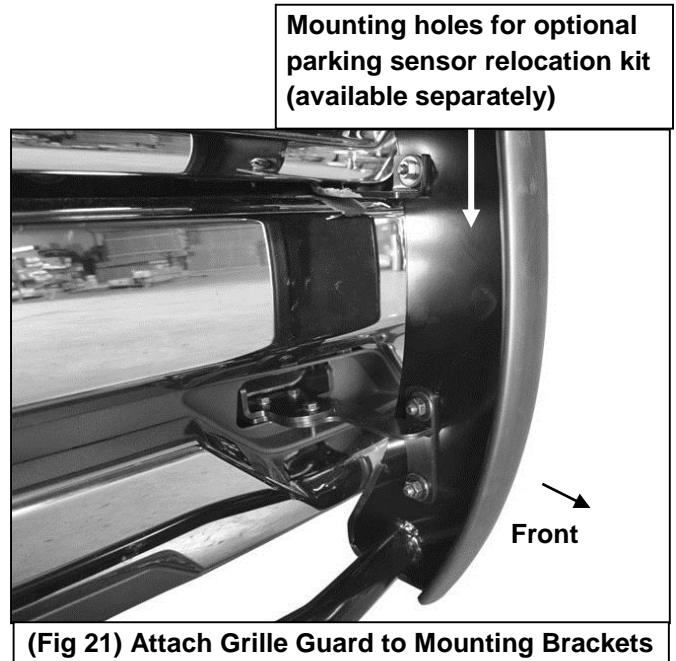
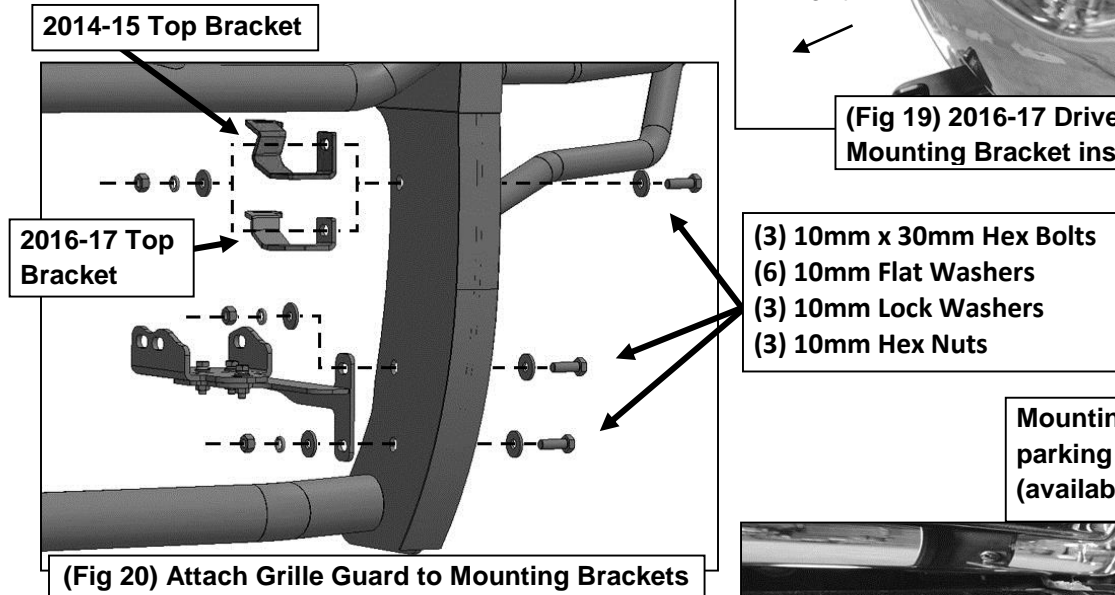
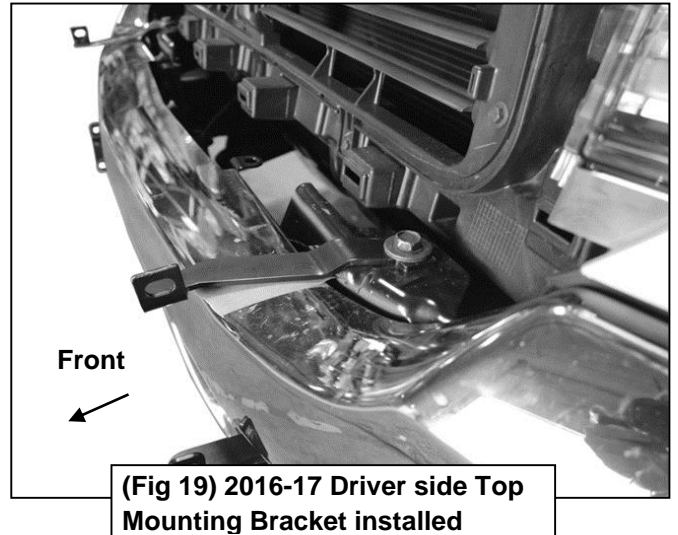
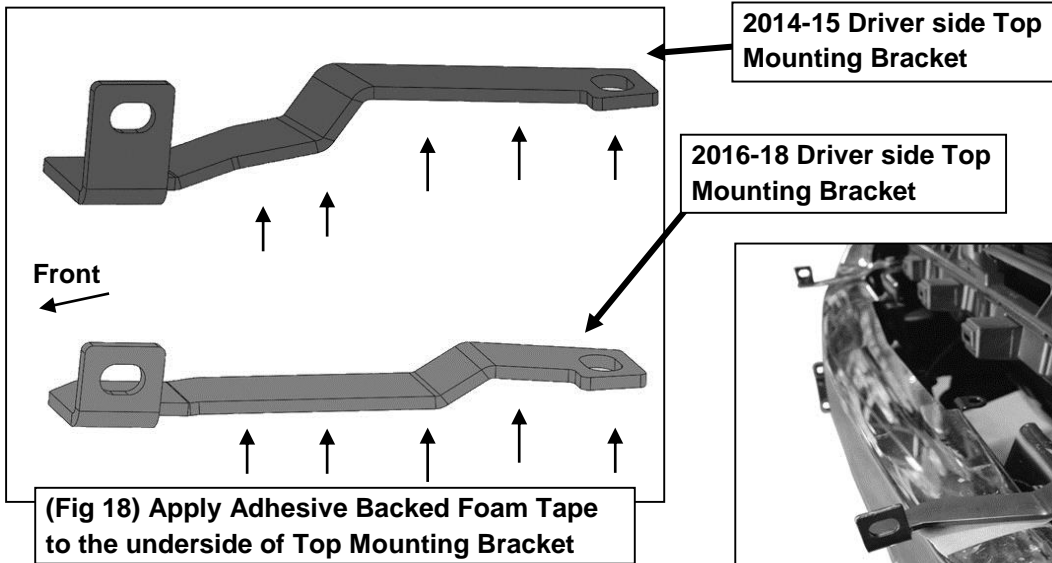

**PRODUCT CARE**

- Periodically check the product to ensure all fasteners are tight and components are intact.
- Regular waxing is recommended to protect the finish of the product.
- **Use ONLY Non-Abrasive automotive wax.** Use of any soap, polish or wax that contains an abrasive is detrimental and can scratch the finish leading to corrosion.
- Aluminum polish may be used to polish small scratches and scuffs for **Stainless Steel finish.**
- Mild soap may be used to clean the product for both **Stainless Steel and Black finish.**

**FAQ's****1. Hardware's are not of correct size.**

*In GMC / Chevrolet truck model 2006 & up, customer needs to reuse the factory body bolts to install the bracket. If your vehicle is not GMC / Chevrolet 2006 & up, ensure that holes are not partially covered with any plastic grommet or rust? If it is, remove the plastic grommet & rust from the thread holes & re-try the installation.*

**2. Mounting Bracket are not getting Installed properly.**

*In some cases Illustration images shown in Installation manual may not be the exactly same as per actual vehicle images ,also if Driver / Passenger side mounting brackets are very identical in the design, suggest referring Parts Identification guide to avoid fitment issue.*

**3. Products are thumping / rattling after installation.**

*Ensure that all required mounting brackets / hardware's are installed & tighten correctly. Suggest using white lithium / regular grease between the metal to metal contact surfaces.*

**4. Side Bar is not aligning with vehicle / Step Pads are not aligning with vehicle doors.**

*Side bar may be interchanged or mounting brackets are not installed at the correct position in the vehicle. Refer Parts identification guide.*

**5. Missing / Excess Hardware.**

*Recheck hardware count as per the part list.*

**6. Product not installing properly.**

*Ensure make model year, cab length and bed size of your vehicle is listed in the application. All installation steps are followed correctly.*

Check out these other TrailFX Products!!

www.TrailFX.com



**SIDE BAR**



**HEADACHE RACKS**



**RUNNING BOARDS**



**ROCKER GUARDS**

Keystone Automotive Operations Inc. (KAO) warrants this product to be free of defects in material and workmanship at the time of purchase by the original retail consumer. KAO disclaims any other warranties, express or implied, including the warranty of fitness for a particular purpose or an intended use. If the product is found to be defective, KAO may replace or repair the product at our option, when the product is returned prepaid, with proof of purchase. Alteration to, improper installation, or misuse of this product voids the warranty. KAO's liability is limited to repair or replacement of products found to be defective, and specifically excludes liability for any incidental or consequential loss or damage.