



Replacement Front Bumper

Part No. FX3000



Fits: 2011 - 2016

Ford Super Duty



ASSISTANCE IS RECOMMENDED.



REMOVE CONTENTS FROM BOX. VERIFY ALL PARTS ARE PRESENT.



READ INSTRUCTIONS CAREFULLY BEFORE STARTING INSTALLATION.

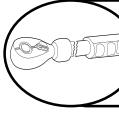

DO NOT OVER TORQUE. STANDARD OPERATING LOAD FOR TIGHTEN BODY MOUNT NUTS & BOLTS VARIES FROM 45 TO 65 FOOT POUND.



60-180 min

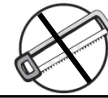

Cutting Not Required



Drilling Not Required



support@trailfx.com



1 866 638 4870



POLISHED STAINLESS STEEL – LIMITED LIFETIME
POWDER COATED BLACK – 3 YEARS

PARTS LIST:

Qty	Part Description	Qty	Part Description
1	Replacement Bumper	8	5x15x1.2mm Flat Washers
4	5x20mm Phillips Screws	4	5mm Hex Nuts
4	5mm Lock Washers	16	12x32x3mm Flat Washers
8	12x50mm Hex Bolts	8	12mm Hex Nuts
8	12mm Lock Washers		

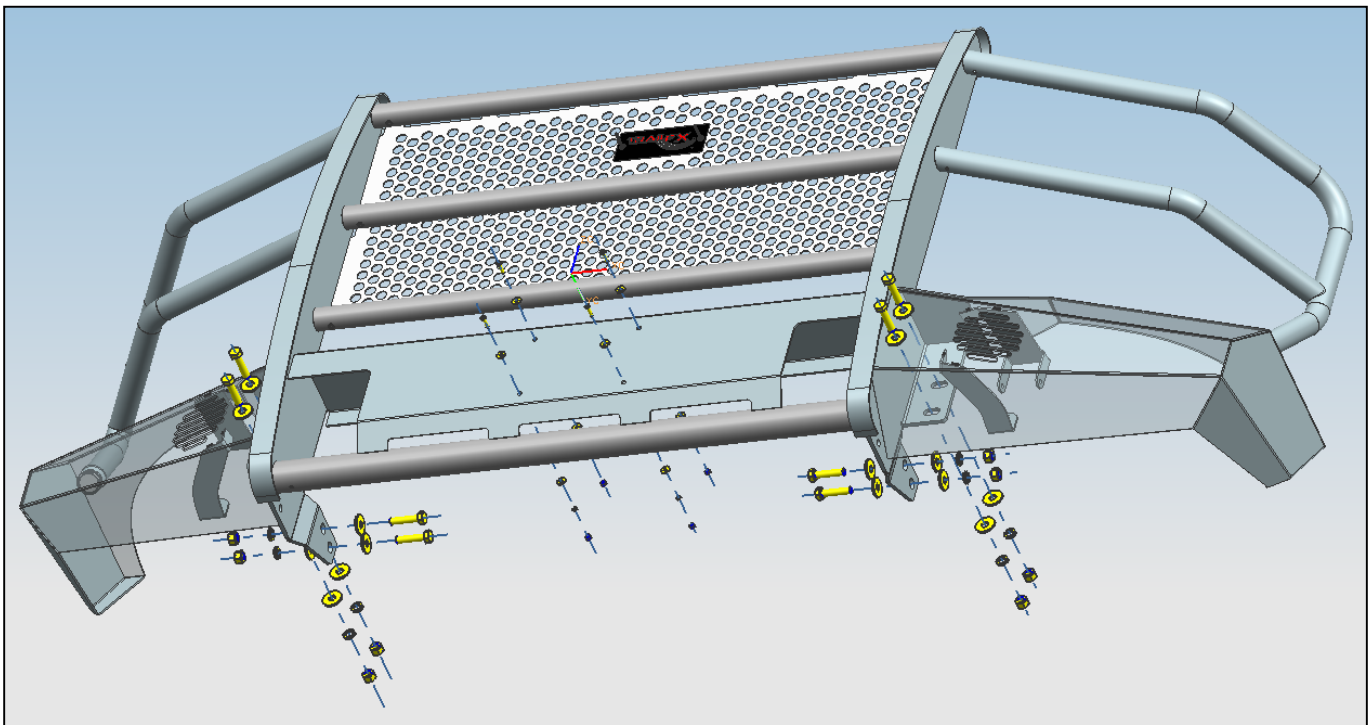

INSTALLATION PROCEDURE

BUMPER IS HEAVY, ASSISTANCE IS HIGHLY RECOMMENDED TO AVOID POSSIBLE INJURY OR DAMAGE TO THE VEHICLE.

Vehicle Preparation

1. Disconnect factory fog lamp harness from the connector on the lower radiator core support.
2. Unclip the splash mat from the factory bumper and fold up out of the way.
3. Remove bumper support bracket screws from the body mount bracket behind the bumper with a 13mm wrench or socket.
4. While supporting the bumper, unscrew the main bumper mounting bolts from the front face of the bumper (**Fig 1**). The bolts will remain captive in the bumper.

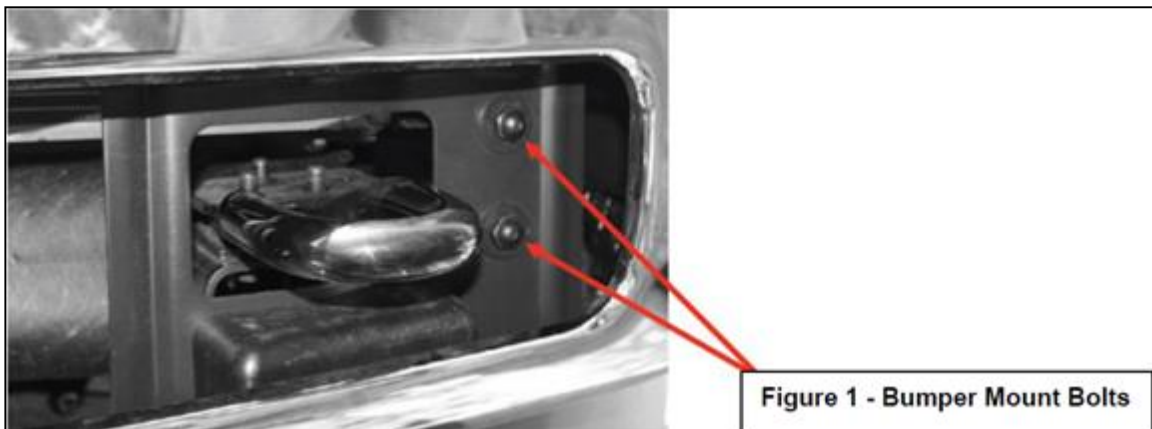

5. Remove OEM bumper assembly and set aside.
6. Remove the under-run guards from both frame rails with an 18mm Socket (**Fig 2**).

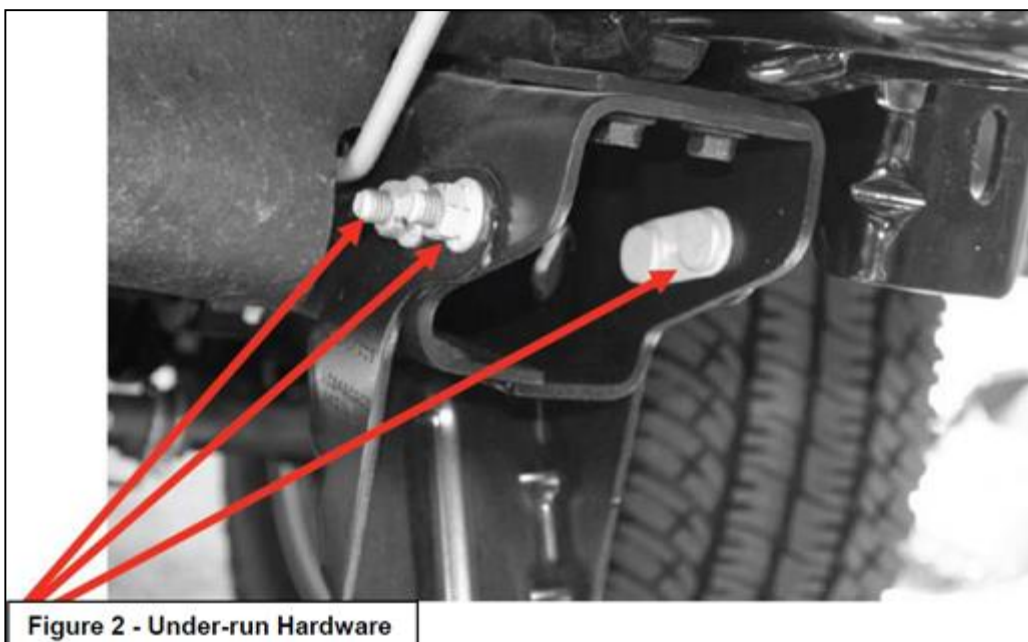

Bumper Installation

1. Remove the fog light from the vehicle. Use the OEM screws and nut plates to fasten the fog light to the bumper (**Fig 3A & 3B**).

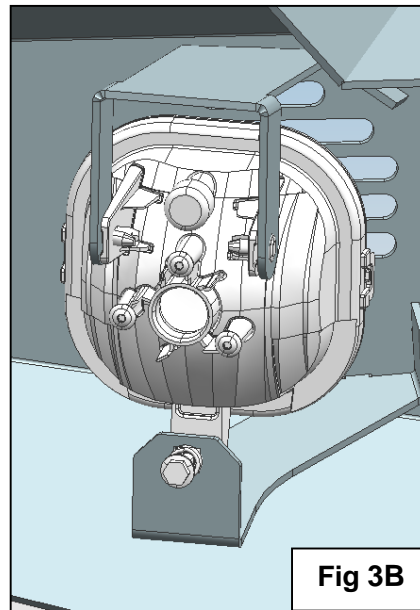
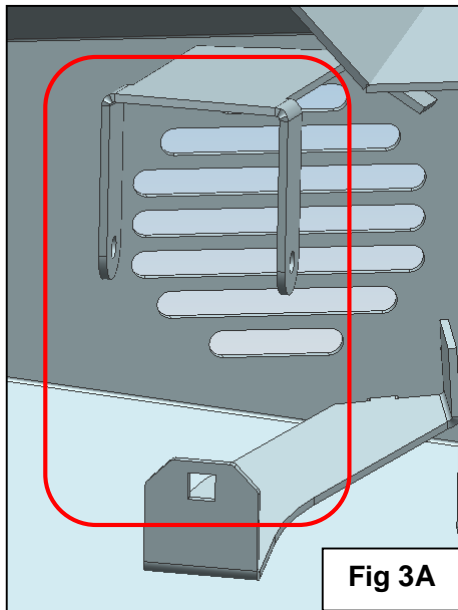

2. Attach the license plate to the Replacement Bumper (**Fig 4**). Fasten the license plate with the hardware.

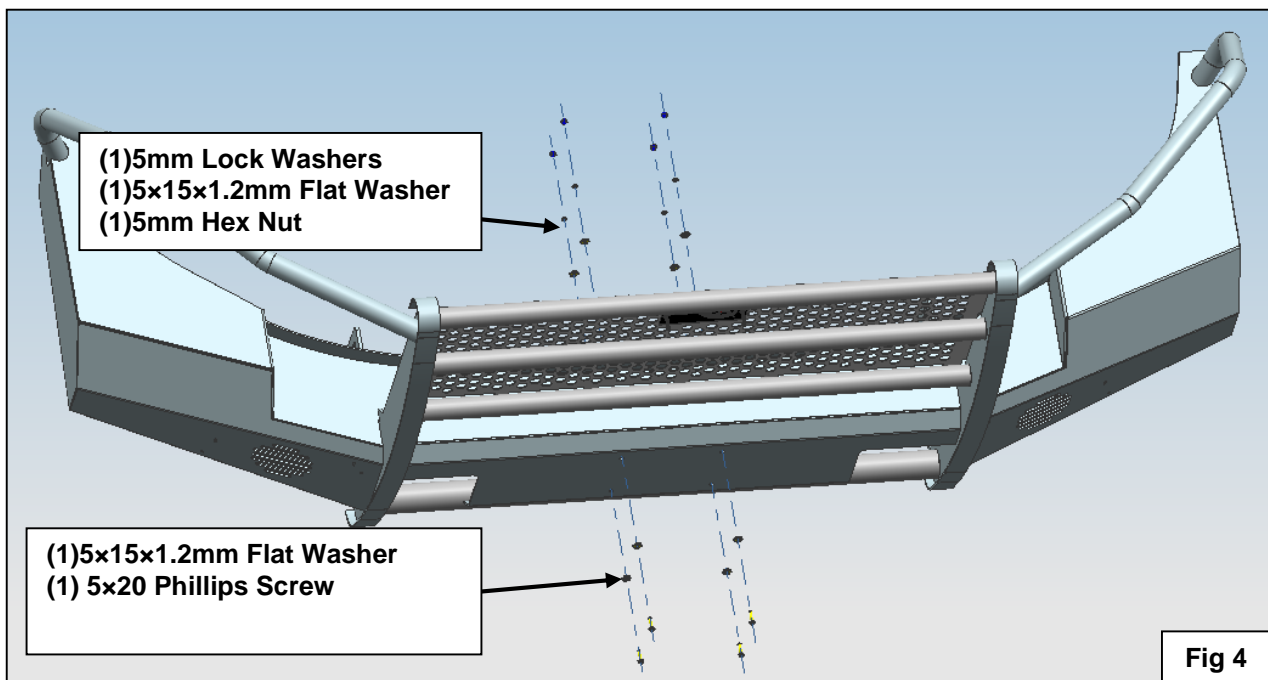

3. Attach the Bumper to the frame with the hardware (**Fig 5A & 5B**).

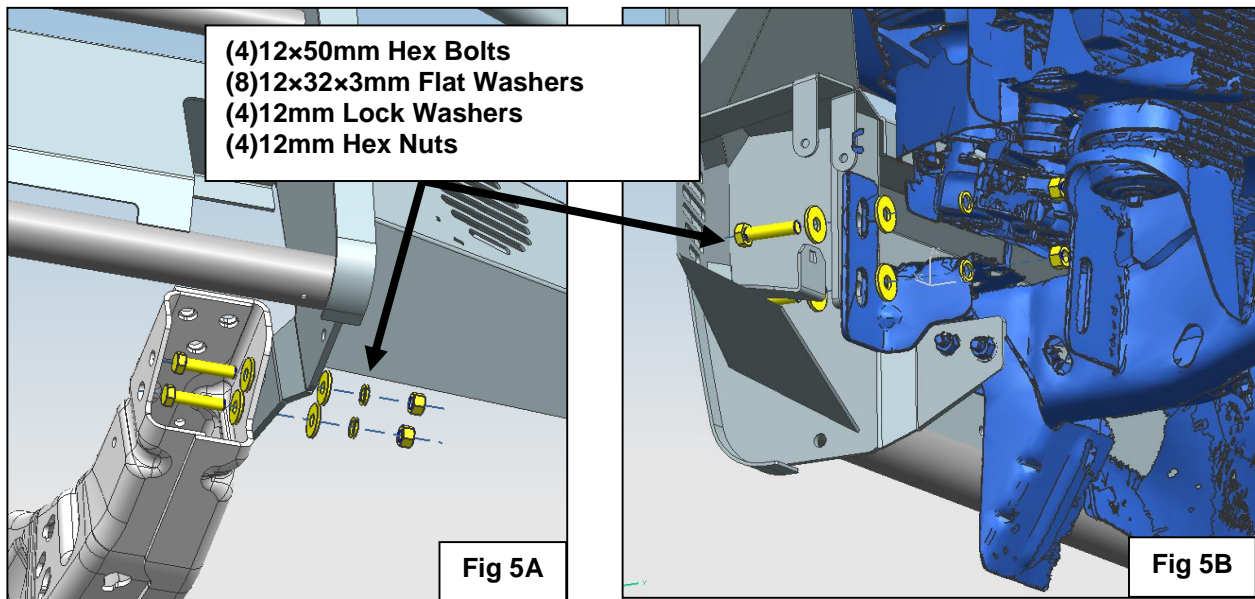

4. Reinstall the factory wiring harness to the fog light.
5. Level and adjust the bumper, make sure that all hardware is secure and tight.
6. Installation is finished, pick up all tools.

PRODUCT CARE

- Periodically check the product to ensure all fasteners are tight and components are intact.
- Regular waxing is recommended to protect the finish of the product.
- **Use ONLY Non-Abrasive automotive wax.** Use of any soap, polish or wax that contains an abrasive is detrimental and can scratch the finish leading to corrosion.
- Aluminum polish may be used to polish small scratches and scuffs for **Stainless Steel finish.**
- Mild soap may be used to clean the product for both **Stainless Steel and Black finish.**

FAQ's**1. Hardware's are not of correct size.**

In GMC / Chevrolet truck model 2006 & up, customer needs to reuse the factory body bolts to install the bracket. If your vehicle is not GMC / Chevrolet 2006 & up, ensure that holes are not partially covered with any plastic grommet or rust? If it is, remove the plastic grommet & rust from the thread holes & re-try the installation.

2. Mounting Bracket are not getting Installed properly.

In some cases Illustration images shown in Installation manual may not be the exactly same as per actual vehicle images ,also if Driver / Passenger side mounting brackets are very identical in the design, suggest referring Parts Identification guide to avoid fitment issue.

3. Products are thumping / rattling after installation.

Ensure that all required mounting brackets / hardware's are installed & tighten correctly. Suggest using white lithium / regular grease between the metal to metal contact surfaces.

4. Side Bar is not aligning with vehicle / Step Pads are not aligning with vehicle doors.

Side bar may be interchanged or mounting brackets are not installed at the correct position in the vehicle. Refer Parts identification guide.

5. Missing / Excess Hardware.

Recheck hardware count as per the part list.

6. Product not installing properly.

Ensure make model year, cab length and bed size of your vehicle is listed in the application. All installation steps are followed correctly.

Check out these other FX-Products!!

www.FX-Products.com



SIDE BAR



HEADACHE RACKS



RUNNING BOARDS



ROCKER GUARDS

Keystone Automotive Operations Inc. (KAO) warrants this product to be free of defects in material and workmanship at the time of purchase by the original retail consumer. KAO disclaims any other warranties, express or implied, including the warranty of fitness for a particular purpose or an intended use. If the product is found to be defective, KAO may replace or repair the product at our option, when the product is returned prepaid, with proof of purchase. Alteration to, improper installation, or misuse of this product voids the warranty. KAO's liability is limited to repair or replacement of products found to be defective, and specifically excludes liability for any incidental or consequential loss or damage.