



Headache Racks

Part No. H0005B/W

Fits: **2009-2015 Ford 250/350 Super duty**
2004-2015 Nissan Titan Crew Cab



REMOVE CONTENTS FROM BOX. VERIFY ALL PARTS ARE PRESENT.



READ INSTRUCTIONS CAREFULLY BEFORE STARTING INSTALLATION.

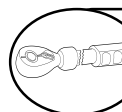

DO NOT OVER TORQUE. STANDARD OPERATING LOAD FOR TIGHTEN BODY MOUNT NUTS & BOLTS VARIES FROM 45 TO 65 FOOT POUND.



60-180 min



Cutting Is Required



Drilling Is Required



support@trailfx.com



1 866 638 4870



POLISHED STAINLESS STEEL – LIMITED LIFETIME
 POWDER COATED BLACK – 3 YEARS

PARTS LIST:

Qty	Part Description	Qty	Part Description
1	Headache Rack	2	Special 10mm "J" Bolts
1	Driver Mounting Base	6	10-1.5mm x 40mm Hex Bolts
1	Passenger Mounting Base	6	10mm x 34mm OD x 3mm Flat Washers
4	12-1.75mm x 40mm Hex Bolts	12	10mm x 24mm OD x 2.2mm Flat Washers
10	12mm x 37mm OD x 3mm Flat Washers	6	10mm Lock Washers
4	12mm Lock Washers	6	10mm Hex Nuts
4	12mm Hex Nuts		

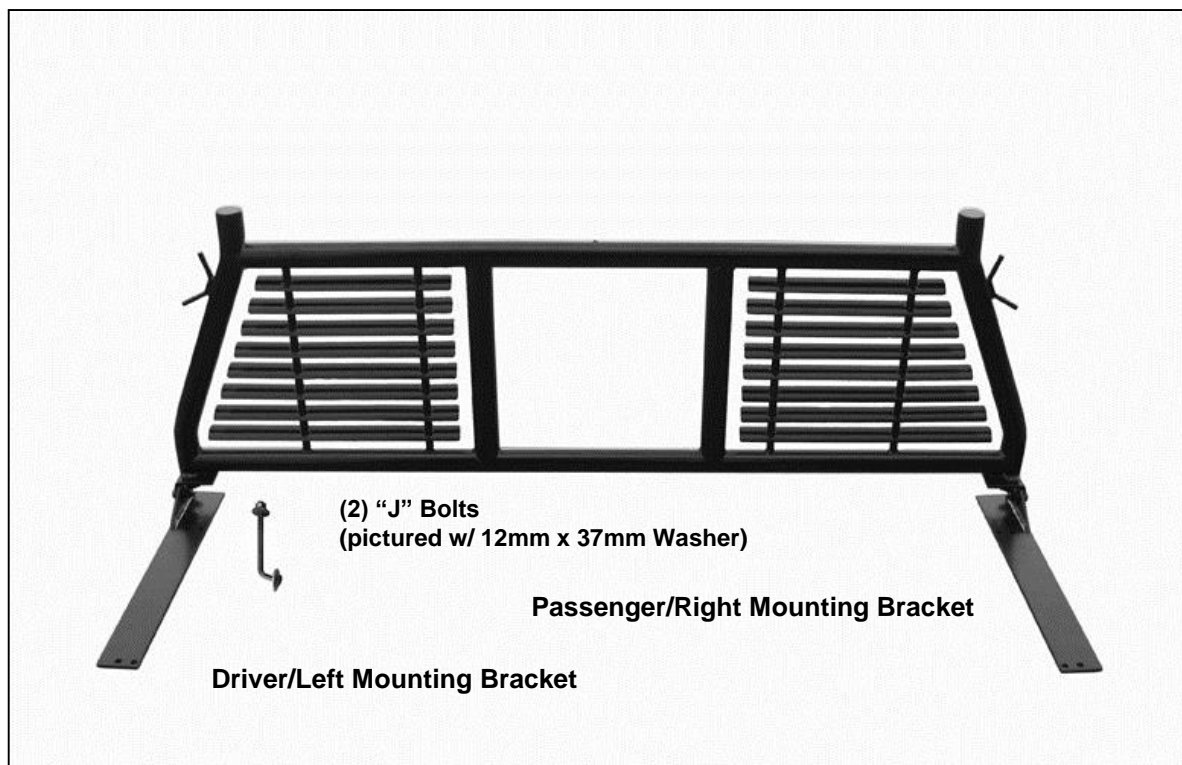

PROCEDURE:

1. Select the driver side Mounting Bracket. Bolt the Bracket onto the outside of the tab on the left/diver side of the Headache Rack with (2) 12mm x 40mm Hex Bolts, (4) 12mm Flat Washers, (2) 12mm Lock Washers and (2) 12mm Hex Nuts. Snug but do not fully tighten hardware at this time. Repeat to attach the passenger side Mounting Bracket. **IMPORTANT:** The Mounting Brackets can be attached to the outside or inside of the Headache Rack if width adjustment is required, (**Figures 1 & 8**). The Brackets can also be switched side to side for additional Rack width if desired.

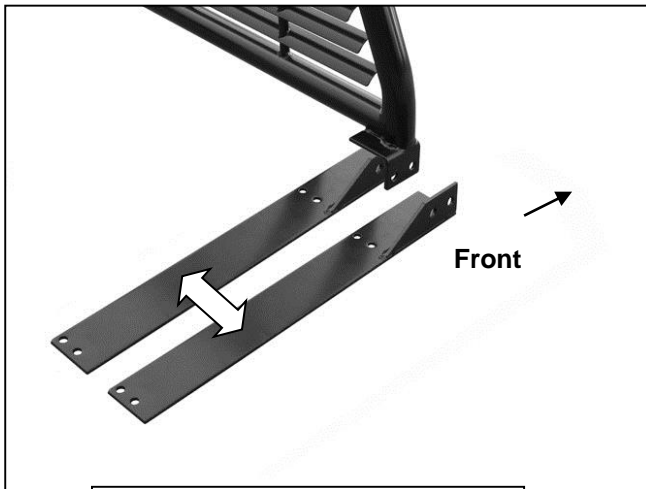
**(Fig 1) Passenger side pictured**

Mounting Brackets can be bolted to the inside or outside of the mounting tab on the Headache Rack to accommodate different truck bed width

2. With assistance, carefully place the Headache Rack onto the approximate mounting position at the front end of the truck bed. Line up the forward end of the Brackets with the end of the bed. Adjust the width of the Brackets for best fit on the truck bed as described in **Step 1**.
 - a. Determine if the forward holes in the Brackets line up with the front stake pockets. **NOTE:** On some vehicles, the front stake pocket may be covered with a plastic bed cap. Remove or cut out the cover as required to gain access to the stake pocket, (**Figure 2**).

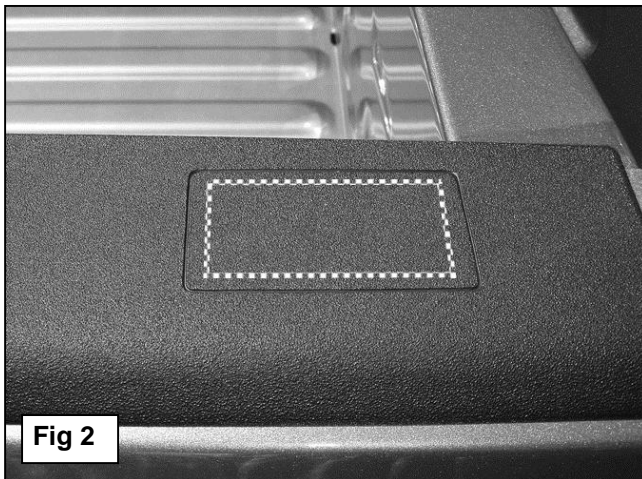
**Fig 2**

- b. On most vehicles, the forward holes will line up with or close to the forward stake pockets. On these vehicles, select (1) 10mm "J" Bolt and (1) 12mm Flat Washer, (**Figure 3**). Slide the Flat Washer over the "J" Bolt down to the head on the bolt. Insert the "J" Bolt into the hole in the side of the stake pocket and up and out the hole in the Bracket, (**Figure 4**). Secure the Bracket to the "J" Bolt with (1) 10mm Small Flat Washer, (1) 10mm Lock Washer and (1) 10mm Hex Nut. Do not fully tighten hardware at this time.
 - c. Repeat to install the passenger side "J" Bolt.
 - d. Skip to **Step 4** for additional drilling and bolting information. **IMPORTANT:** On some models, the forward holes will not line up with the stake pockets. If the Brackets do not line up correctly with the stake pockets or the "J" Bolt does not reach up to the Bracket, the "J" Bolts will not be used and proceed to **Step 3**. **Do not attach the Headache Rack with only the "J" Bolts! Additional hardware is required and drilling is mandatory.**



(Fig 3) 10mm "J" Bolt w/12mm Flat Washer



(Fig 4) Use the "J" Bolt to secure the front mounting holes on the Bracket to the stake pocket if possible. Do not drill any mounting holes until after all mounting locations are checked for clearance

3. With the Headache Rack properly positioned on the top of the bed, locate the best location to drill. Use the provided holes in the Brackets if possible, **(Figure 5)**. Do not drill the top of the bed until you have made absolutely sure that you can gain access to the bottom of the mounting locations. **(Figure 6)**.
- Use the pre-punched holes in the Bracket if possible. If you are using the "J" Bolts, only mark the rear mounting location on the top of the bed, **(Figure 5)**. If "J" Bolts are not used, mark the forward and rear mounting locations, **(Figure 7)**.
 - Each mounting location on the Bracket has (2) holes. Use the holes in the center if possible to better support the Rack. The holes toward the inner edge are provided for models with inner panels on the bed and a narrow mounting surface along the inner edge.

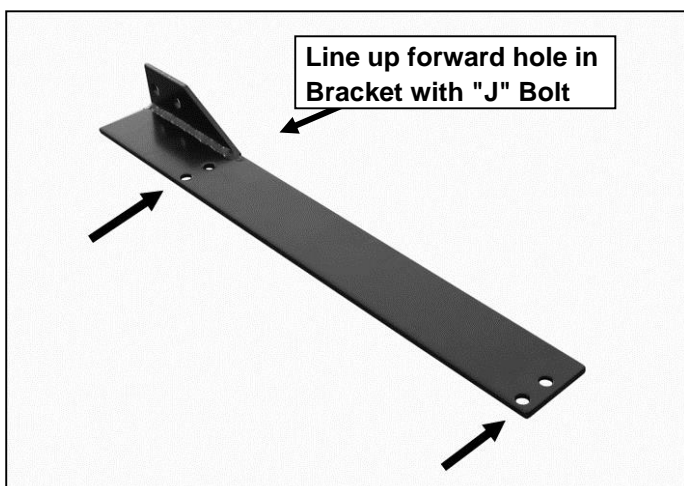

(Fig 5) Insert 10mm "J" Bolt with (1) 12mm Flat Washer into hole in side of stake pocket and up through opening and forward hole in the Bracket.

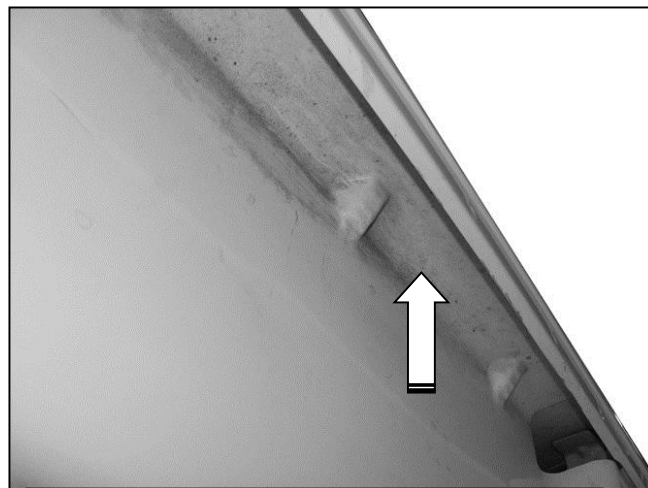

(Fig 6) Before drilling any holes through the top of the bed, check the bottom of the top edge of the bed for hardware clearance.

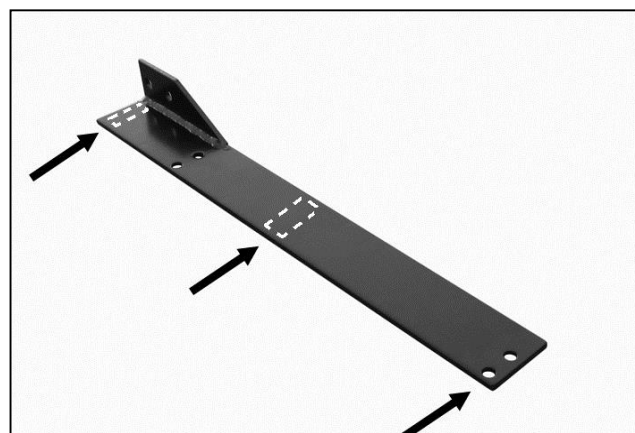

(Fig 7) If the forward hole in the Bracket does not line up with the stake pocket or the J Bolt will not fit properly, drill the necessary holes and bolt the Bracket directly to the top of the bed.

4. Once all locations have been checked and the holes marked on the top of the bed, remove the Headache Rack assembly. Drill the required holes as marked with a 7/16" drill bit. Bolt the Bracket to each mounting hole with (1) 10mm Hex Bolt, (2) 10mm Flat Washers, (1) 10mm Lock Washer and (1) 10mm Hex Nut, **(Figure 9)**. **IMPORTANT:** To help support the Headache Rack, large 10mm Flat Washers have been provided. Use the larger Washers under the top of the bed if possible. Smaller 10mm Flat Washers have also been provided if there is insufficient room.

12mm Hex Bolt
(2) 12mm Flat Washers
12mm Lock Washer
12mm Hex Nut

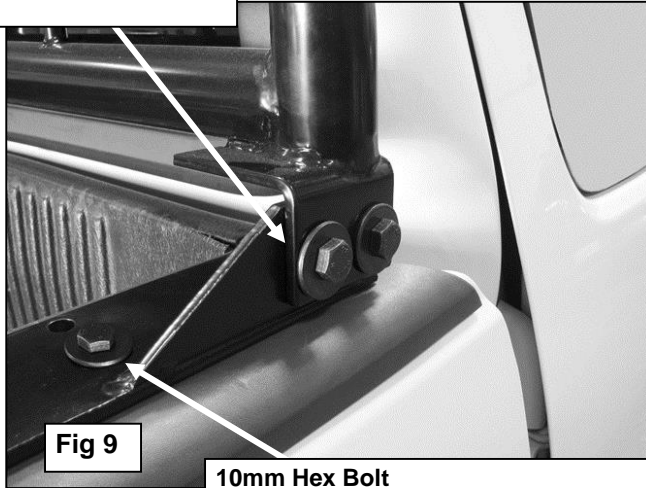
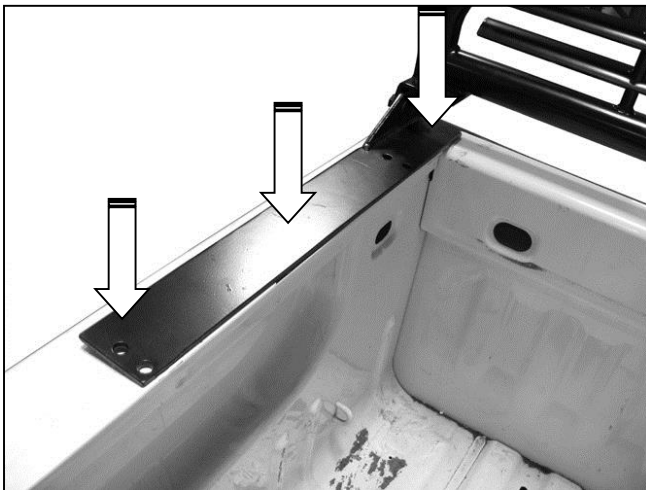

Fig 9

10mm Hex Bolt
10mm Small Flat Washer (top)
10mm Large Flat Washer (bottom)
10mm Lock Washer
10mm Hex Nut

5. The provided mounting holes in the Brackets will allow installation on most but not all vehicles. If the holes are not in the correct location for your particular model, drill new mounting holes through the Bracket and top of the bed as necessary for the best possible fit, **(Figures 7 & 8)**.
6. On some models, the location of the inner stake pocket interferes with the forward mounting holes. For additional support, drill an additional hole at the front of the Bracket, **(Figures 7 & 8)**. Additional hardware has been provided to bolt the Brackets to the front of the bed.



(Fig 8) Optional "3-Bolt" per side installation pictured.

7. Center the Headache Rack on the truck, check the alignment and tighten all hardware.

PRODUCT CARE

- Periodically check the product to ensure all fasteners are tight and components are intact.
- Regular waxing is recommended to protect the finish of the product.
- **Use ONLY Non-Abrasive automotive wax.** Use of any soap, polish or wax that contains an abrasive is detrimental and can scratch the finish leading to corrosion.
- Aluminum polish may be used to polish small scratches and scuffs for **Stainless Steel finish.**
- Mild soap may be used to clean the product for both **Stainless Steel and Black finish.**

FAQ's**1. Hardware's are not of correct size.**

In GMC / Chevrolet truck model 2006 & up, customer needs to reuse the factory body bolts to install the bracket. If your vehicle is not GMC / Chevrolet 2006 & up, ensure that holes are not partially covered with any plastic grommet or rust? If it is, remove the plastic grommet & rust from the thread holes & re-try the installation.

2. Mounting Bracket are not getting Installed properly.

In some cases Illustration images shown in Installation manual may not be the exactly same as per actual vehicle images ,also if Driver / Passenger side mounting brackets are very identical in the design, suggest referring Parts Identification guide to avoid fitment issue.

3. Products are thumping / rattling after installation.

Ensure that all required mounting brackets / hardware's are installed & tighten correctly. Suggest using white lithium / regular grease between the metal to metal contact surfaces.

4. Side Bar is not aligning with vehicle / Step Pads are not aligning with vehicle doors.

Side bar may be interchanged or mounting brackets are not installed at the correct position in the vehicle. Refer Parts identification guide.

5. Missing / Excess Hardware.

Recheck hardware count as per the part list.

6. Product not installing properly.

Ensure make model year, cab length and bed size of your vehicle is listed in the application. All installation steps are followed correctly.

Check out these other TrailFX Products!!

www.TrailFX.com



BULL BAR



GRILLE GUARDS



BED RAILS



RUNNING BOARDS

Keystone Automotive Operations Inc. (KAO) warrants this product to be free of defects in material and workmanship at the time of purchase by the original retail consumer. KAO disclaims any other warranties, express or implied, including the warranty of fitness for a particular purpose or an intended use. If the product is found to be defective, KAO may replace or repair the product at our option, when the product is returned prepaid, with proof of purchase. Alteration to, improper installation, or misuse of this product voids the warranty. KAO's liability is limited to repair or replacement of products found to be defective, and specifically excludes liability for any incidental or consequential loss or damage.