

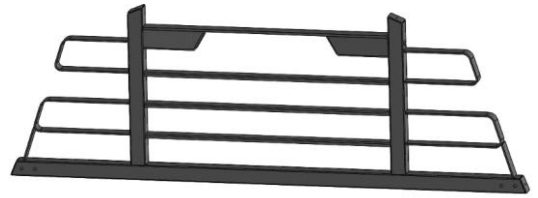

Headache Racks

Part No. HR003B



Fits: 2019 SILVERADO 1500

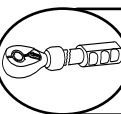

REMOVE CONTENTS FROM BOX. VERIFY ALL PARTS ARE PRESENT.

READ INSTRUCTIONS CAREFULLY BEFORE STARTING INSTALLATION.

DO NOT OVER TORQUE. STANDARD OPERATING LOAD FOR TIGHTENING BODY MOUNT NUTS & BOLTS VARIES FROM 18 TO 20 FOOT POUND FOR M8 AND 35-40 FOOT POUND FOR M10.



60-180 min



CUTTING NOT REQUIRED



DRILLING REQUIRED



support@trailfx.com



1 866 638 4870



WARRANTY POLISHED STAINLESS STEEL - LIMITED LIFETIME
POWDER COATED BLACK - 3 YEARS

PARTS LIST:

Qty	Part Description	Qty	Part Description
1	Headache Rack	14	10mm x 24mm OD x 2.2mm Flat Washers
1	Driver/Left Mounting Bracket	8	10mm Lock Washers
1	Passenger/Right Mounting Bracket	8	10mm Hex Nuts
2	12mm x 37mm OD x 3mm Flat Washers	4	8-1.25mm x 70mm Hex Bolts
2	10mm J-Bolts	8	8mm x 24mm OD x 2mm Flat Washers
6	10-1.5mm x 40mm Hex Bolts	4	8mm Nylon Lock Nuts
6	10mm x 34mm OD x 3mm Flat Washers		

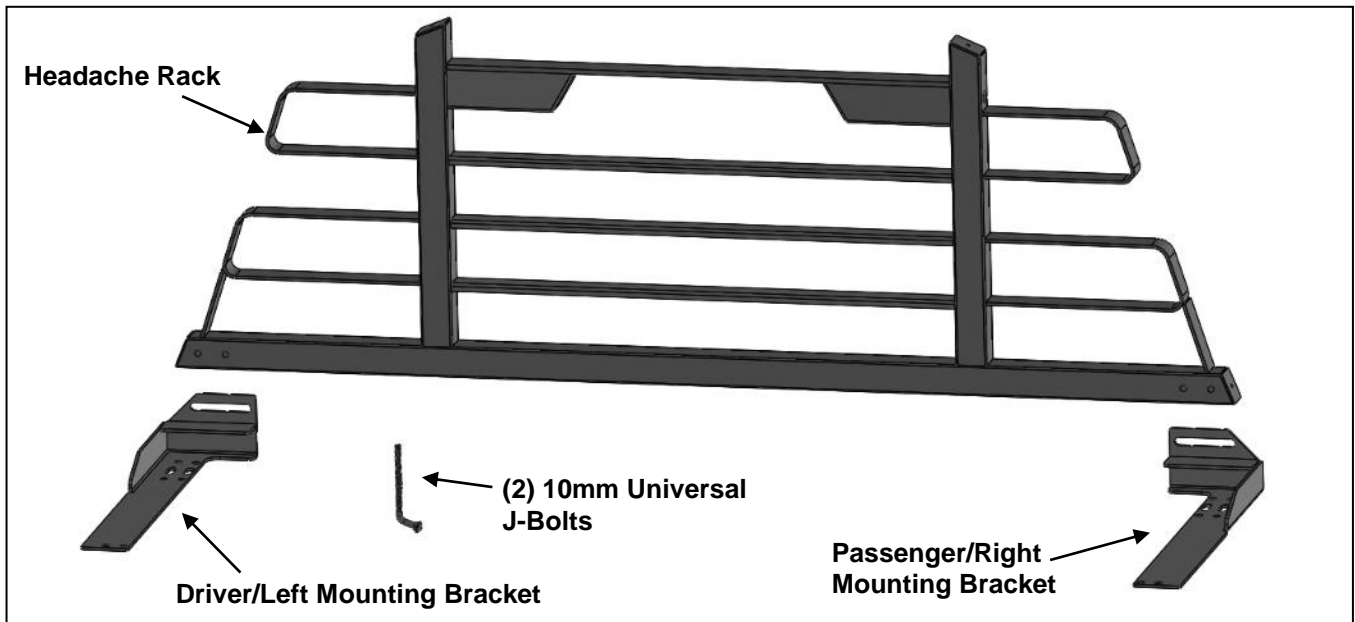

PROCEDURE:

REMOVE CONTENTS FROM BOX. VERIFY ALL PARTS ARE PRESENT. READ INSTRUCTIONS CAREFULLY BEFORE STARTING INSTALLATION. ASSISTANCE IS RECOMMENDED. DRILLING IS REQUIRED. CUTTING OF PLASTIC BED LINER (IF EQUIPPED) MAY BE REQUIRED.

1. Select the Passenger/Right Mounting Bracket. Attach the Bracket to the Headache Rack with (2) 8mm Hex Bolts, (4) 8mm Flat Washers and (2) 8mm Nylon Lock Nuts, **(Figure 1)**. Do not tighten hardware. Repeat this Step to attach the Driver/Left Mounting Bracket.

2. With assistance, carefully place the Headache Rack onto the approximate mounting position at the front end of the bed. Line up the forward end of the Brackets with the end of the bed but leave clearance between the Rack and the back of the cab.
 - a. Determine if the forward mounting holes in the Brackets line up with the front stake pockets. **NOTE:** On some vehicles, the front stake pocket may be covered with a plastic bed cap. Remove or cut out the cover as required to gain access to the stake pocket, **(Figure 2)**.
 - b. On most vehicles, the forward holes will line up with or close to the forward stake pockets. On these vehicles, select (1) 10mm J-Bolt and (1) 12mm Flat Washer, **(Figure 3)**. Slide the Flat Washer over the J-Bolt down to the head on the bolt. Insert the J-Bolt into the hole in the side of the stake pocket and up and out the hole in the Bracket, **(Figures 4 & 5)**. Secure the Bracket to the J-Bolt with (1) 10mm Small Flat Washer, (1) 10mm Lock Washer and (1) 10mm Hex Nut, **(Figure 4)**. Do not fully tighten hardware at this time.
 - c. Repeat to attach the Driver/Left Mounting Bracket to the bed of the vehicle.
 - d. Skip to **Step 3** for additional drilling and bolting information. **IMPORTANT:** On some models, the forward holes will not line up with the stake pockets. If the Brackets do not line up correctly with the stake pockets or the J-Bolt does not reach up to the Bracket, the J-Bolts will not be used and proceed to **Step 3**. **Do not attach the Headache Rack with only the J-Bolts! Additional hardware is required, and drilling is mandatory.**
3. With the Headache Rack properly positioned on the top of the bed, locate the best location to drill. Use the provided holes in the Brackets if possible, **(Figure 6)**. Do not drill the top of the bed until you have made absolutely sure that you can gain access to the bottom of the mounting locations. **(Figure 7)**.
 - a. Use the pre-punched holes in the Bracket if possible. If you are using the J-Bolts, only mark the rear mounting location on the top of the bed. If J-Bolts are not used, mark the forward and rear mounting locations, **(Figure 6)**.
 - b. Each mounting location on the Bracket has (2) holes. Use the holes in the center if possible, to better support for the Rack. The holes toward the inner edge are provided for models with inner panels on the bed and a narrow mounting surface along the inner edge.
4. Once all locations have been checked and the holes marked on the top of the bed, remove the Headache Rack assembly. Drill the required holes as marked with a 7/16" drill bit. Bolt the Bracket to each mounting hole with (1) 10mm Hex Bolt, (2) 10mm Flat Washers, (1) 10mm Lock Washer and (1) 10mm Hex Nut, **(Figures 8 & 9)**. **Note:** To help support the Headache Rack, large 10mm Flat Washers have been provided. Use the larger Washers under the top of the bed if possible. Smaller 10mm Flat Washers have also been provided if there is insufficient room.
5. The provided mounting holes in the Brackets will allow installation on most but not all vehicles. If the holes are not in the correct location for your model, drill new mounting holes through the Bracket and top of the bed as necessary for the best possible fit. Additional hardware has been provided; use is optional.
6. Center the Headache Rack on the vehicle, check the alignment and tighten all hardware. Do periodic inspections to the installation to make sure that all hardware is secure and tight.

To protect your investment, wax this product after installing. Regular waxing is recommended to add a protective layer over the finish. Do not use any type of polish or wax that may contain abrasives that could damage the finish.

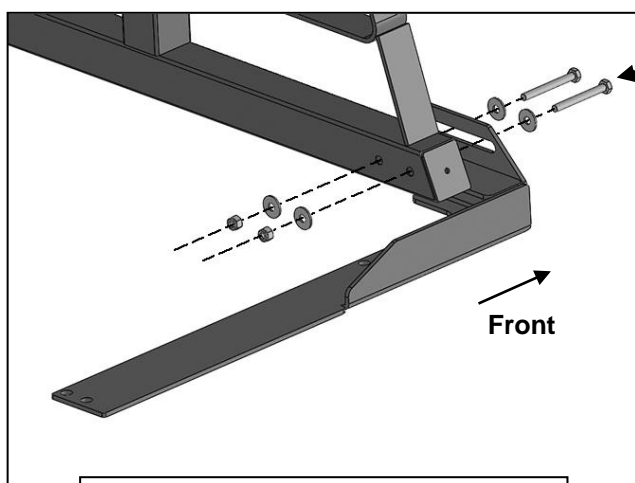

(Fig 1) Attach Passenger/Right Bracket to Headache Rack assembly

**(2) 8mm Hex Bolts
(4) 8mm Flat Washers
(2) 8mm Nylon Lock Nuts**

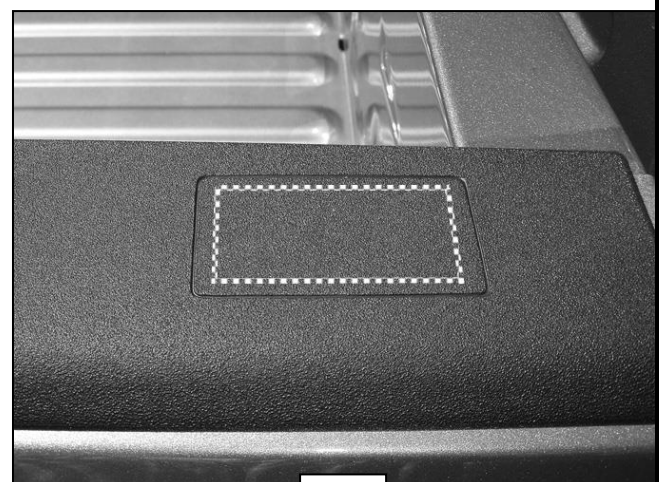
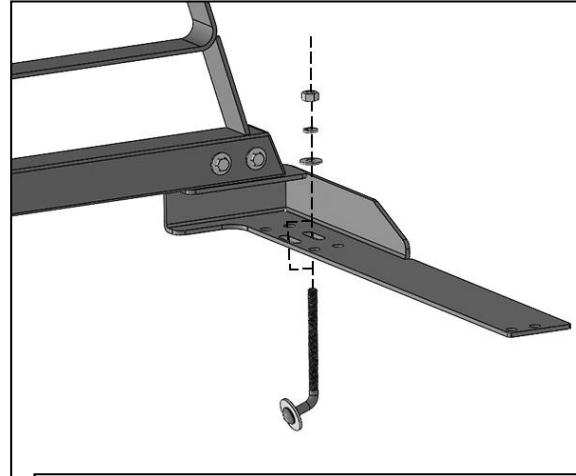

Fig 2



(Fig 3) 10mm "J" Bolt w/12mm Flat Washer



(Fig 4) Use the 10mm J-Bolt to secure the front mounting holes on the Bracket to the stake pocket if possible. Do not drill any mounting holes until after all mounting locations are checked for clearance

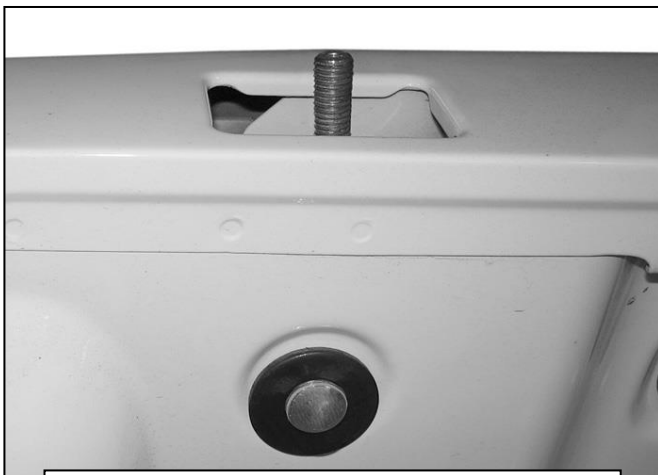

(Fig 5) Use the 10mm J-Bolt to secure the front mounting holes on the Bracket to the stake pocket if possible. Do not drill any mounting holes until after all mounting locations are checked for clearance

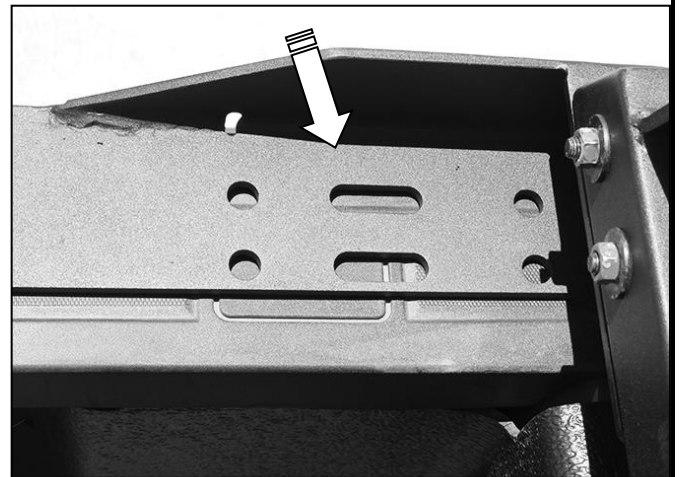

(Fig 6) If the forward hole in the Bracket does not line up with the stake pocket or the 10mm J-Bolt will not fit properly, mark the locations on the top of the bed and drill 7/16" holes as required to attach the Bracket directly to the top of the bed.

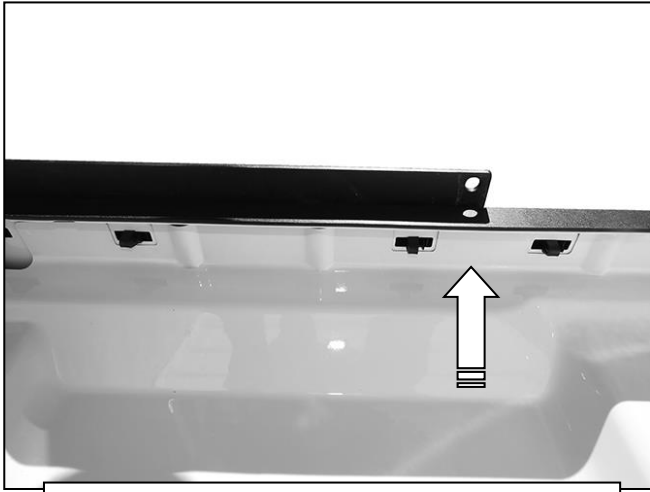

(Fig 7) Before drilling any holes through the top of the bed, check the bottom of the top edge of the bed for hardware clearance.

- 10mm Hex Bolt
- 10mm Small Flat Washer (top)
- 10mm Small Flat Washer (bottom)
- or
- 10mm Large Flat Washer (bottom)
- 10mm Lock Washer
- 10mm Hex Nut

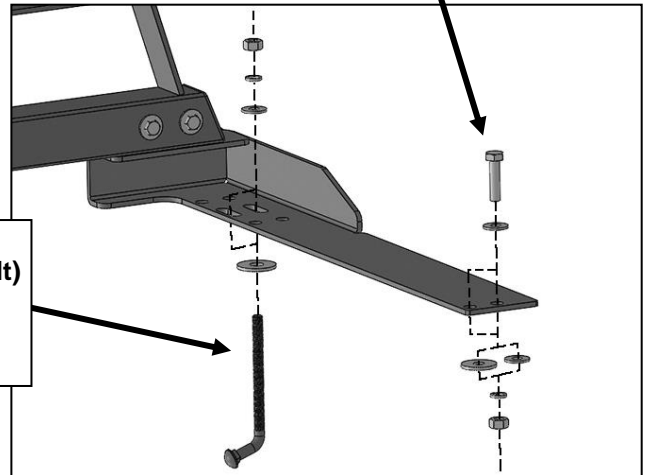

- 10mm J-Bolt
- 12mm Large Flat Washer (on J-Bolt)
- 10mm Small Flat Washer
- 10mm Lock Washer
- 10mm Hex Nut

(Fig 8) Attach the Headache Rack to the Bed of the vehicle

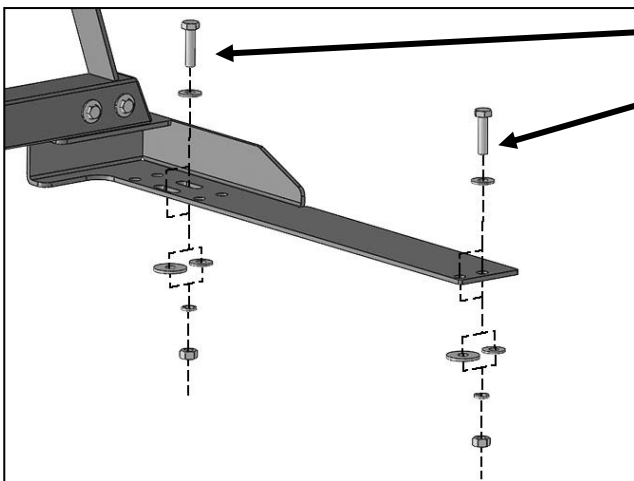

- (2) 10mm Hex Bolts
- (2) 10mm Small Flat Washers (top)
- (2) 10mm Small Flat Washers (bottom)
- or
- (2) 10mm Large Flat Washers (bottom)
- (2) 10mm Lock Washers
- (2) 10mm Hex Nuts

(Fig 9) Bracket attached with Hex Bolts only

PRODUCT CARE

- Periodically check the product to ensure all fasteners are tight and components are intact.
- Regular waxing is recommended to protect the finish of the product.
- **Use ONLY Non-Abrasive automotive wax.** Use of any soap, polish or wax that contains an abrasive is detrimental and can scratch the finish leading to corrosion.
- Aluminum polish may be used to polish small scratches and scuffs for **Stainless Steel finish.**
- Mild soap may be used to clean the product for both **Stainless Steel and Black finish.**

FAQ's**1. Hardware's are not of correct size.**

In GMC / Chevrolet truck model 2006 & up, customer needs to reuse the factory body bolts to install the bracket. If your vehicle is not GMC / Chevrolet 2006 & up, ensure that holes are not partially covered with any plastic grommet or rust? If it is, remove the plastic grommet & rust from the thread holes & re-try the installation.

2. Mounting Bracket are not getting Installed properly.

In some cases Illustration images shown in Installation manual may not be the exactly same as per actual vehicle images ,also if Driver / Passenger side mounting brackets are very identical in the design, suggest referring Parts Identification guide to avoid fitment issue.

3. Products are thumping / rattling after installation.

Ensure that all required mounting brackets / hardware's are installed & tighten correctly. Suggest using white lithium / regular grease between the metal to metal contact surfaces.

4. Side Bar is not aligning with vehicle / Step Pads are not aligning with vehicle doors.

Side bar may be interchanged or mounting brackets are not installed at the correct position in the vehicle. Refer Parts identification guide.

5. Missing / Excess Hardware.

Recheck hardware count as per the part list.

6. Product not installing properly.

Ensure make model year, cab length and bed size of your vehicle is listed in the application. All installation steps are followed correctly.

Check out these other TrailFX Products!!

www.TrailFX.com

**BULL BAR****GRILLE GUARDS****BED RAILS****RUNNING BOARDS**

Keystone Automotive Operations Inc. (KAO) warrants this product to be free of defects in material and workmanship at the time of purchase by the original retail consumer. KAO disclaims any other warranties, express or implied, including the warranty of fitness for a particular purpose or an intended use. If the product is found to be defective, KAO may replace or repair the product at our option, when the product is returned prepaid, with proof of purchase. Alteration to, improper installation, or misuse of this product voids the warranty. KAO's liability is limited to repair or replacement of products found to be defective, and specifically excludes liability for any incidental or consequential loss or damage.