



# Jeep Product

## Part No. J029T

Fits: 2007-Current 2007-18 JEEP WRANGLER JK 4-DOOR (EXCLUDES JL MODELS)



60-180 min



Cutting Not Required



Drilling Is Optional



REMOVE CONTENTS FROM BOX. VERIFY ALL PARTS ARE PRESENT.



support@trailfx.com



READ INSTRUCTIONS CAREFULLY BEFORE STARTING INSTALLATION.



1 866 638 4870

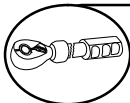

DO NOT OVER TORQUE. STANDARD OPERATING LOAD FOR TIGHTEN BODY MOUNT NUTS &amp; BOLTS VARIES FROM 45 TO 65 FOOT POUND.

POLISHED STAINLESS STEEL – LIMITED LIFETIME  
POWDER COATED BLACK – 3 YEARS

### PARTS LIST:

Qty	Part Description	Qty	Part Description
1	Driver/Left Front Leg (A)	6	12mm Rubber Plug/Grommets
1	Passenger/Right Front Leg (B)	4	12-1.75mm x 35mm Hex Bolts
1	Driver/Left Rear Top Leg (C)	4	12mm x 32mm OD x 3mm Flat Washers
1	Passenger/Right Rear Top Leg (D)	4	12mm Lock Washers
1	Driver/Left Rear Bottom Leg (E)	4	10-1.50mm x 35mm Hex Bolts
1	Passenger/Right Rear Bottom Leg (F)	4	10mm x 27mm OD x 3mm Flat Washers
2	Short Rear Mounting Bracket (drill mount) (G)	4	10mm Lock Washers
2	Metal Backing Plates (drill mount) (H)	8	8-1.25mm x 70mm Allen Bolts (for Cross Bar)
8	Knobs with 8mm Nylon Locking Hex Nut (I)	14	8-1.25mm x 65mm Allen Bolts
1	Front Main Cross Tube / Light Bar (J)	12	8-1.25 x 35mm Hex Bolts Gr. 10.9
1	Rear Main Cross Tube / Light Bar (K)	8	8mm x 24mm OD x 2mm Large Flat Washers
4	Cargo Cross Bar/Basket Holder (L)	52	8mm x 16mm OD x 1.6mm STD Flat Washers
2	Long Side Tube (M)	8	8mm Lock Washers
2	12mm Double Nut Plates (N)	18	8mm Nylon Lock Nuts
2	Rubber Bumpers (O)	2	ST # 5 x 30mm Sheetmetal Screw
6	Adhesive Backed Foam Gaskets (P)	2	ST 9.8mm x 5.4mm x 1.1mm Flat Washers

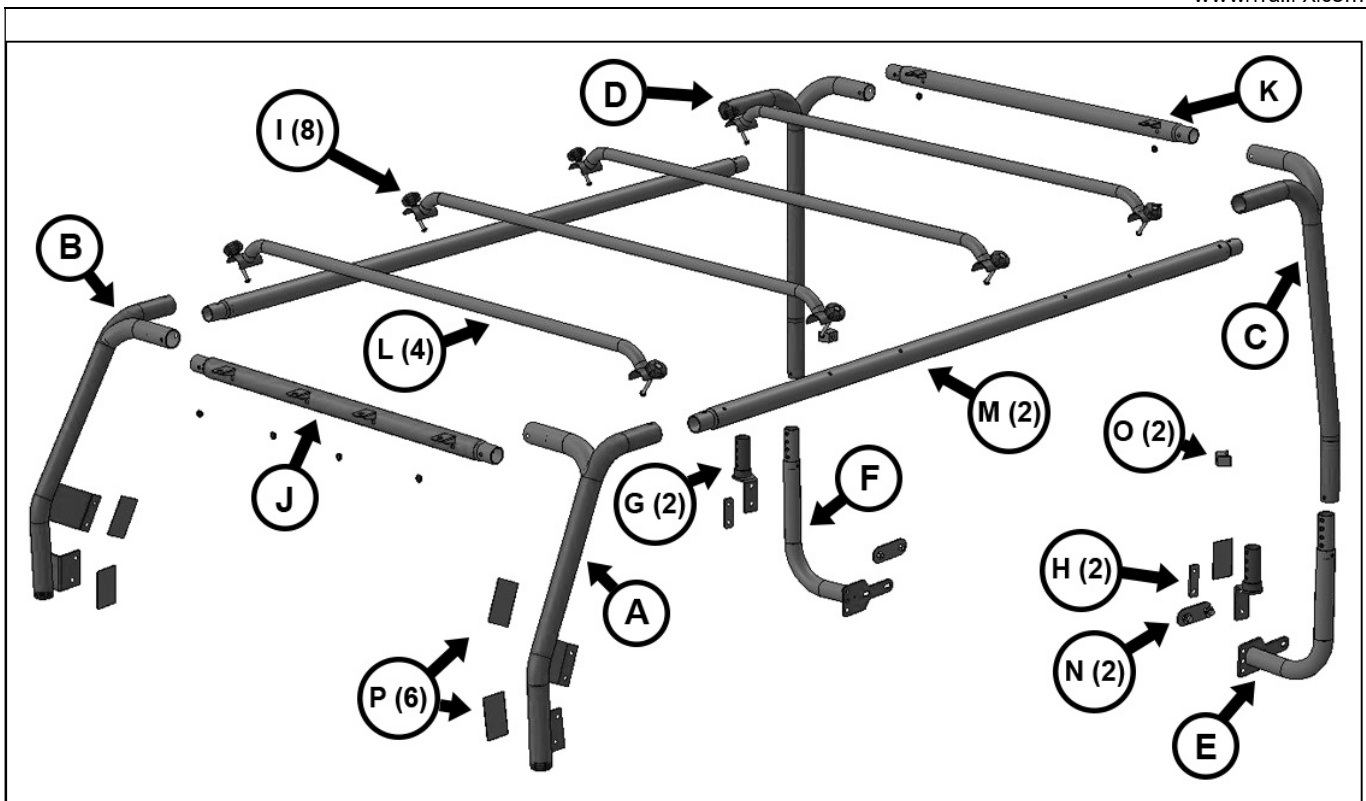

**CAUTION:** Recommended load rate is 350 lb. Excessive weight will greatly reduce the stability of your vehicle and increase the vehicle's tendency to overturn. The manufacturer makes no representation or warranty as to the amount of weight that your vehicle can safely carry. For guidance, we recommend that you consult the vehicle manufacturer. Secure all payloads properly for safe transportation.

The Roof Rack is NOT designed as a roll over roll bar.

**NOTE:** The "no drilling required, bolt-on" bottom rear leg mounts, (E & F), of your new Roof Rack are designed to work with aftermarket bumpers only and are not compatible with the factory bumper.

#### PROCEDURE:

REMOVE CONTENTS FROM BOX. VERIFY ALL PARTS ARE PRESENT. READ INSTRUCTIONS CAREFULLY. ASSISTANCE IS REQUIRED. DRILLING MAY BE REQUIRED.

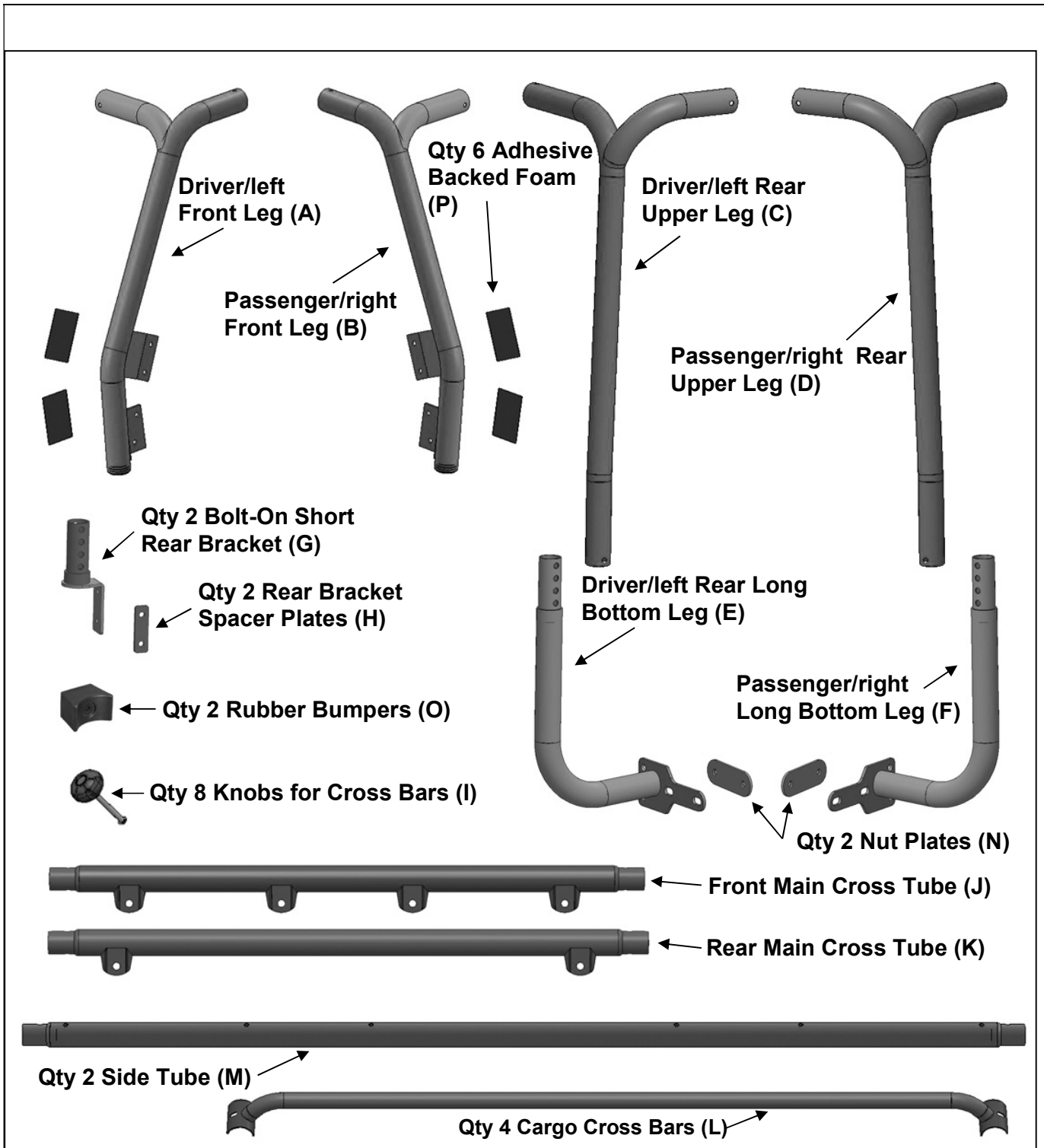

**(Step 1)** Remove (4) factory screws from passenger/right windshield frame (arrows).

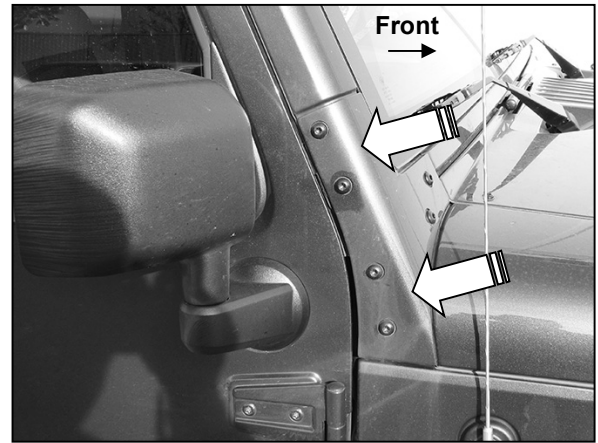

**(Step 2)** Select passenger/right front Rack Leg.

Attach (2) Adhesive Backed Foam Pads to back of mounting plates on lower Rack Leg. Trim Foam to fit as necessary.

Attach Rack Leg to windshield frame with the included:

- (4) 8mm x 35mm Hex bolts
- (4) 8mm Lock Washers
- (4) 8mm x 24mm Large Flat Washers

**Do not fully tighten hardware at this time**

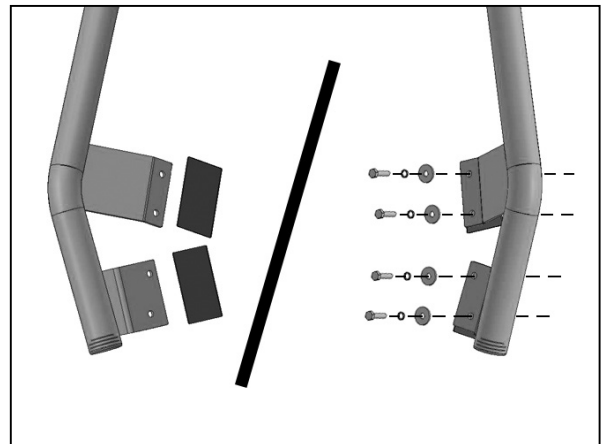

**(Step 3)** Passenger/right front Rack Leg installed. Removable tape (not included but pictured) used to protect finish on vehicle during initial installation. Use of tape is optional.



**(Step 4)** Select and separate the slightly longer (8) 8mm x 70mm Button Head Bolts from the rest of the hardware. The longer bolts will only be used to attach the cargo Cross Tubes, (see **Step 22**).

Select Front Main Cross Tube. Insert Cross Tube into passenger/right Front Rack Leg. **NOTE:** Cross Tube can be installed with light tabs to the front or rear.

Attach Cross Tube to Rack Leg with:

- (1) 8mm x 65mm Button Head Bolt
- (2) 8mm Small Flat Washers
- (1) 8mm Nylon Lock Nut

Repeat **Steps 1—3** to attach the driver/left Front Rack Leg and to attach Cross Tube to Rack Leg.

**Do not tighten hardware at this time**

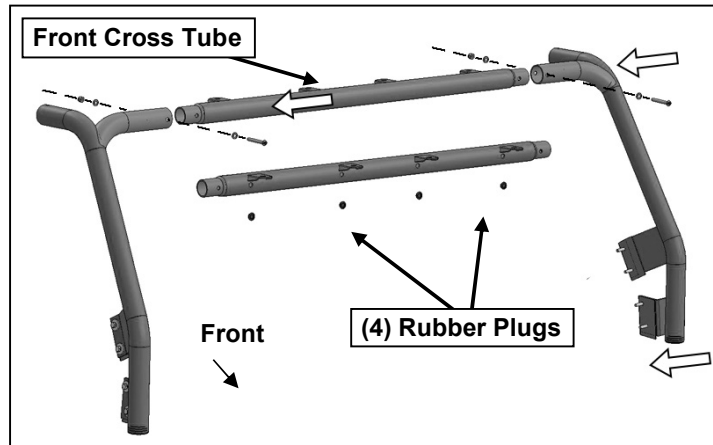

**Passenger/right Side Tube-**  
**NOTE** angle of mounting  
holes for Cargo Cross Tubes

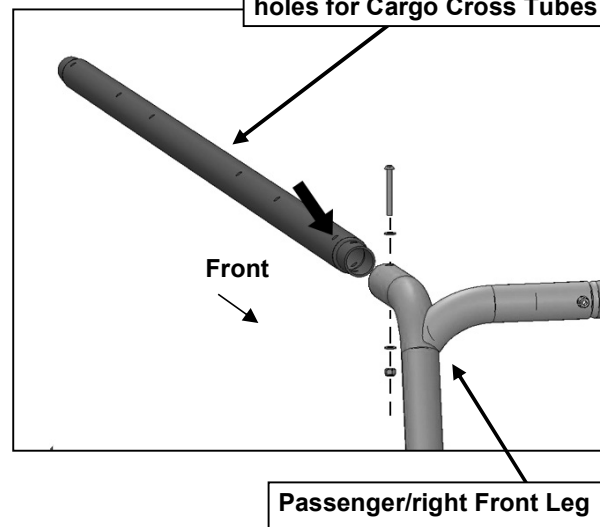

**(Step 5)** Select (1) Side Tube. Slide Side Tube into the previously installed passenger/right front Rack Leg. **NOTE:** The Side Tube must be installed with mounting holes for Cargo Cross Tubes oriented as illustrated (arrow).

Attach Side Tube to front Leg with:

- (1) 8mm x 65mm Button Head Bolt
- (2) 8mm Small Flat Washers
- (1) 8mm Nylon Lock Nut

**Do not tighten hardware at this time.**

**(Step 6)** Temporarily cover open end toward rear of Side Tube with removable tape or padding (not included) to protect top from damage.



**(Step 7)** Move to the rear of the vehicle. Determine correct procedure to install the rear mounting legs. **IMPORTANT:** Models with factory or “wrap around” style bumper, drilling is required to attach short Rear Mounting Base to side of body. Skip to **Step 14**.

**(Step 8) Models with aftermarket bumper (IMPORTANT: side of frame must be clear and accessible as pictured)**  
Remove the (2) bolts from each side, attaching the bumper (driver/left side pictured).

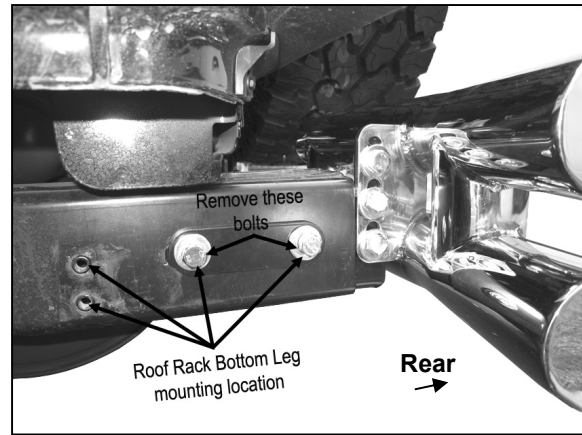

**(Step 9)** Select the passenger/right rear Lower Leg.

Attach the Leg to the side of the frame with the included:

- (2) 12mm x 35mm Hex Bolts
- (2) 12mm Lock Washers
- (2) 12mm Flat Washers
- (2) 10mm x 35mm Hex Bolts
- (2) 10mm Lock Washers
- (2) 10mm Flat Washers

**Do not tighten hardware at this time.**

**NOTE:** Insert the included 12mm Double Nut Plates, if needed, into the open end of the frame to attach the Lower Leg to the side of the frame.

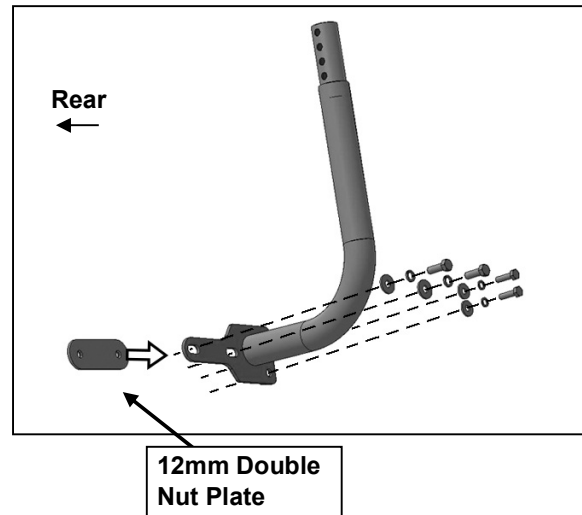

**(Step 10)** Passenger/right Rack Leg pictured.

Repeat **Steps 8 & 9** to install the driver/left rear Lower Rack Leg

**Do not tighten hardware at this time.**



**(Step 11)** Select the passenger/right rear Upper Rack Leg.  
Attach the Upper Leg to the Side Rail with the included:

- (1) 8mm x 65mm Button Head Bolt
- (2) 8mm Small Flat Washers
- (1) 8mm Nylon Lock Nut

**NOTE:** Only slide Upper Leg down into Lower Rack Leg but do not attach it at this time.

**Do not tighten hardware at this time.**

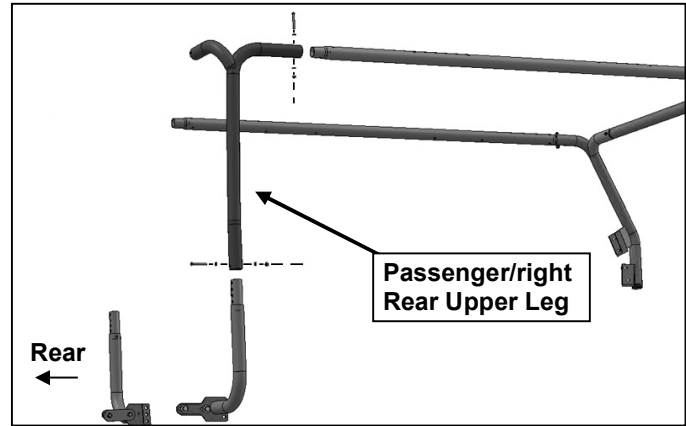

**(Step 12)** Select the Rear Main Cross Tube. Insert Cross Tube into passenger/right Rear Upper Rack Leg.  
**NOTE:** Cross Tube can be installed with light tabs to the front or rear as desired.

Attach Cross Tube to passenger/right Rack Leg only with the included;

- (1) 8mm x 65mm Button Head Bolt
- (2) 8mm Small Flat Washers
- (1) 8mm Nylon Lock Nut

**Do not tighten hardware at this time**

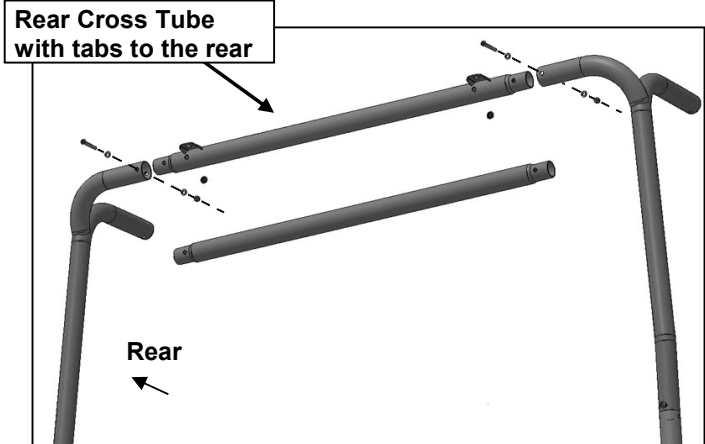

**(Step 13)** Repeat **Steps 11 & 12** to attach the driver/left Rear Upper Rack Leg to the Side Tube and the Cross Tube.

Attach the Rack Leg with the included;

- (2) 8mm x 65mm Button Head Bolts
- (4) 8mm Small Flat Washers
- (2) 8mm Nylon Lock Nuts

**Do not tighten hardware at this time**

Once all tubes are in place, attach rear Rack Legs to Lower Legs with the included:

- (2) 8mm x 65mm Button Head Bolts
- (4) 8mm Small Flat Washers
- (2) 8mm Nylon Lock Nuts

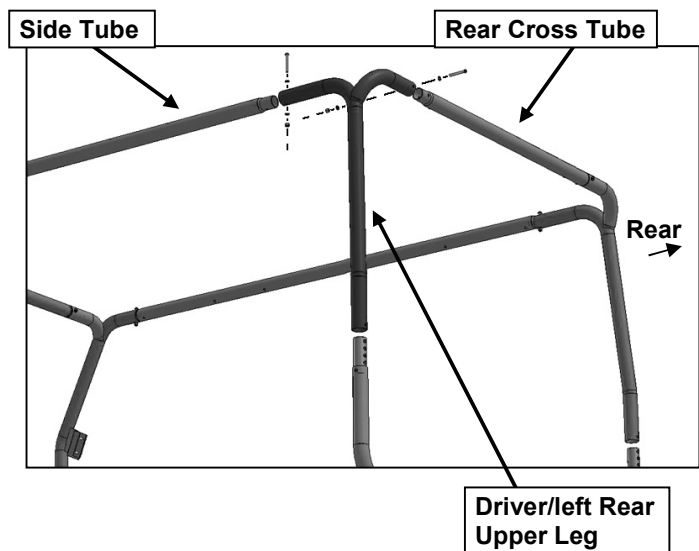

**(Step 14) Models with original equipment or “wrap around” style bumper**

**(NOTE: side of frame blocked)**

Temporarily remove the rear taillight assemblies (driver/left side pictured).

Repeat **Steps 11—13** to assemble the 3pc rear Rack section, (Cross Tube and Upper Legs).

**IMPORTANT:** Place padding on vehicle top to support rack and protect top.

**Do not tighten hardware at this time**

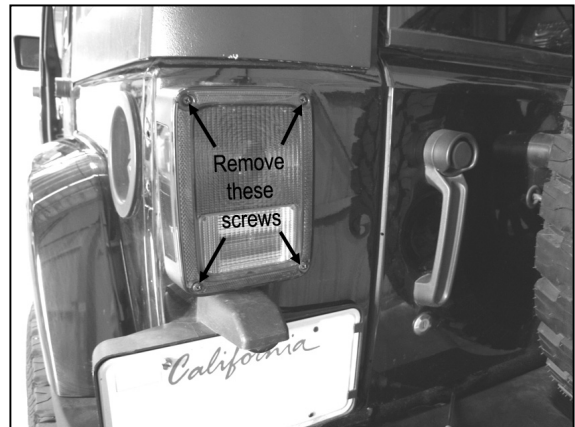

**(Step 15) Select (1) Short Bottom Bracket.**

Apply adhesive backed Foam Gasket to the back of the mounting tab and trim Gasket as required.

Repeat this Step to apply Foam Gasket to the remaining Short Bottom Bracket.

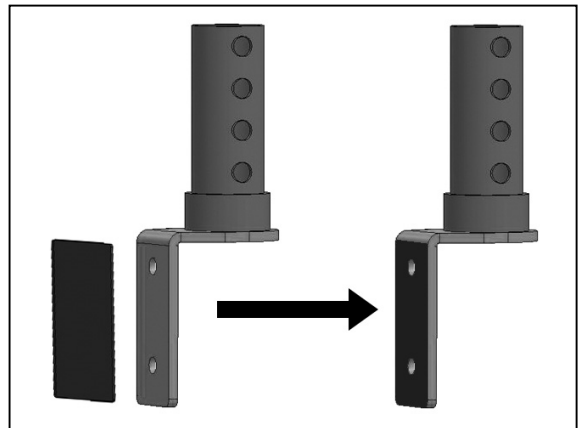

**(Step 16) With assistance, hold the rear section of the Roof Rack up.**

Attach the Short Bottom Bracket to the bottom of the passenger/right Rear Top Leg section with the included:

- (1) 8mm x 65mm Allen Bolt,
- (2) 8mm Flat Washers
- (1) 8mm Nylon Lock Nut.

**Do not tighten hardware at this time**

**IMPORTANT!** Use padding to protect vehicle, do not place Roof Rack directly on vehicle to attach the Rear Bottom Legs or damage to the vehicle may occur.

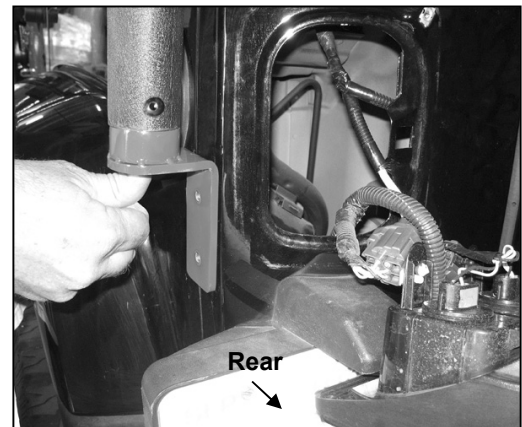

**WARNING: Before drilling into the vehicle, verify that all parts of the Roof Rack are completely clear of any top mechanisms, (soft and hard tops), sunroofs and factory or added accessories**



**(Step 17)** Align the Side Tubes parallel with the roof of the vehicle. Use the holes in the Short Bottom Bracket as a template and mark the drilling location on the vehicle.

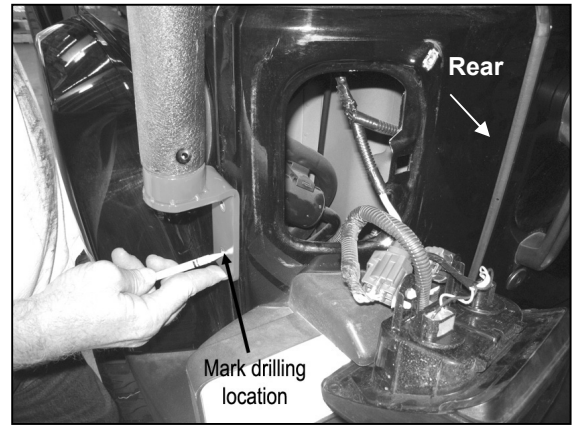

**(Step 18) NOTE:** Center of the holes must be 3/4" from body seam, (vertical dashed line for example). Make sure marks are in same location for both sides of the vehicle.

**Mark location to drill  
3/4" from seam-  
toward rear of vehicle**

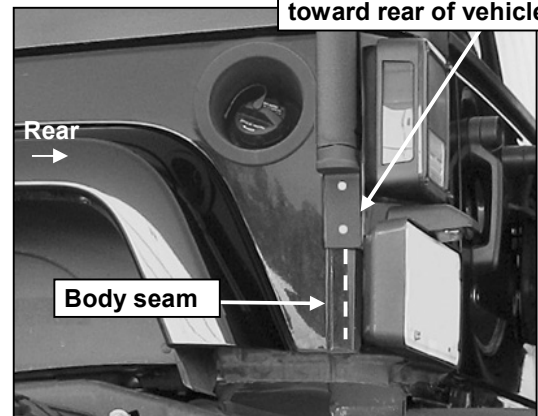

**(Step 19)** Once you have marked the drill location on both sides of the vehicle, temporarily remove the 3pc rear assembly of the Roof Rack, (Cross Tube and Top Legs).

Remove the Short Bottom Brackets from the Rear Legs. Temporarily remove the driver/left Leg from the Crossbar.

Use a 3/8" drill bit to drill out the (4) marked locations. **IMPORTANT:** Any cutting or drilling too may break or shatter. Government regulations require safety glasses & equipment at all times when cutting or drilling.

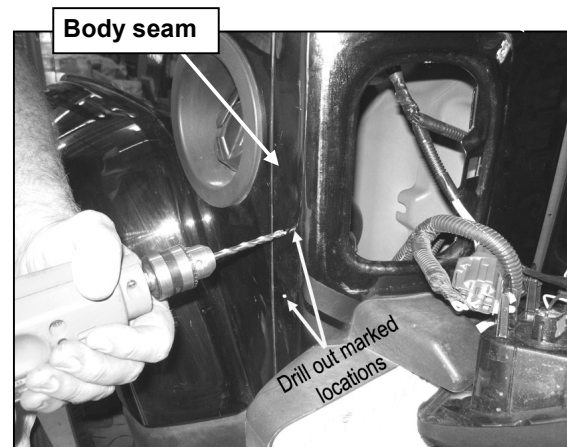

**(Step 20)** Select (1) Short Bottom Bracket. Insert (2) 8mm x 35mm Hex Bolts with (2) 8mm Small Flat Washers through the Short Bottom Bracket and body. Slide (1) 2-hole Metal Plate over the 8mm Hex Bolts.

Secure the Metal Plate to the Hex Bolts with the included (2) 8mm Small Flat Washers and (2) 8mm Nylon Lock Nuts.

**Do not tighten hardware at this time**

Repeat **Steps 11—13** to attach the passenger/right Leg and Cross Tube to the Short Bottom Bracket. Next reattach the driver/left Leg to the Cross Tube, Side Tube and Short Bottom Bracket.

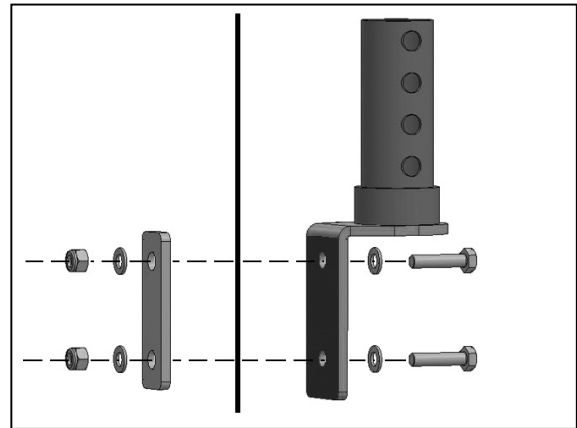

**(Step 21)** To better support the Roof Rack when loaded, (2) Rubber Bumpers are included in the installation kit.

The Rubber Bumpers can be installed at a point 29" up from the end of the Rear Leg for vehicles with hard tops or at 6-3/8" for vehicles with hard or soft tops, **(Figure 7)**.

Mark the location on the side of the tube facing the vehicle. Remove the Rear Leg. **NOTE**, it may be necessary to partially disassemble the rear section of the Rack to remove the Legs.

Drill an 1/8" hole into the Rear Leg. Drill only through the side requiring the Rubber Bumper. Do not drill through both sides of the tube.

Attach the Rubber Bumper to the Rear Leg with (1) #5 x 30mm Screw and (1) 5mm Flat Washer.

Snug but do not over tighten or the Rubber Bumper will be deformed.

Once both Rubber Bumpers are installed, reassemble the Rack.

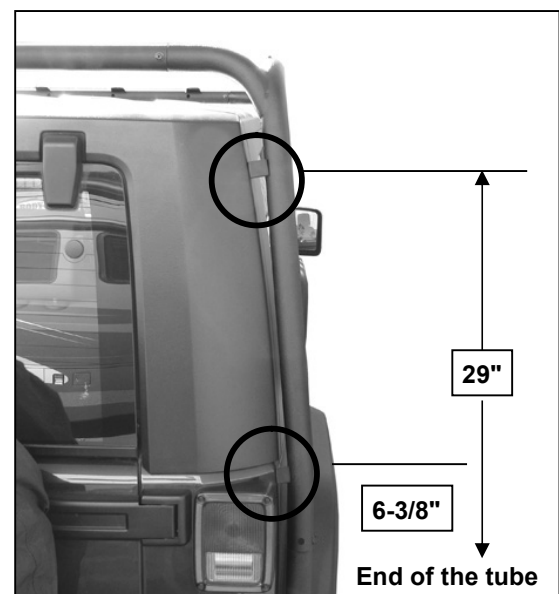
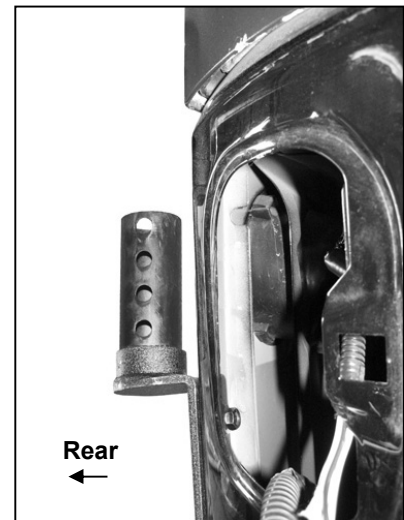

**(Step 22)** To secure the Cargo Cross Bars to Side Tubes, insert (1) 8mm x 70mm Allen Bolt with (1) 8mm Small Flat Washer up through the bottom hole in the Side Tube and through the Cross Bar.

Place (1) 8mm Small Flat Washer over the bolt and secure it with the included Plastic Knob.

**Do not tighten hardware at this time**

Repeat Step to install remaining Cargo Cross Bars

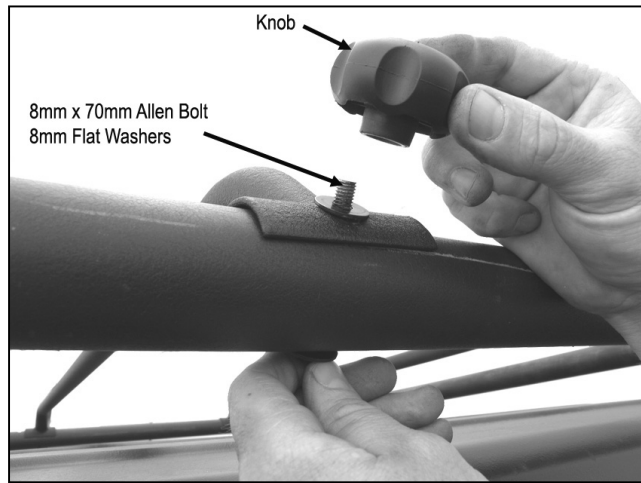

**(6) Cargo Cross Bar mounting locations on Side Tube**

**(Step 23) NOTE:** There are additional holes in each Side Tubes to allow front to back adjustment of Cargo Cross Bar locations for different basket designs or accessories. Install Cargo Cross Bars in desired locations to properly support all accessories.

**IMPORTANT:** Extra 8mm x 65mm hardware has been provided to fill unused holes in Side Tubes cross bar holes.

**(Step 24)** Align Roof Rack properly and **tighten all hardware at this time only.** **IMPORTANT:** Do periodic inspections to the installation to make sure all hardware is secure and tight.

To protect your investment, do not use any type of polish or wax that may contain abrasives that could damage or cloud the finish. Use mild soap and water only to clean Rack.

**PRODUCT CARE**

- Periodically check the product to ensure all fasteners are tight and components are intact.
- Regular waxing is recommended to protect the finish of the product.
- **Use ONLY Non-Abrasive automotive wax.** Use of any soap, polish or wax that contains an abrasive is detrimental and can scratch the finish leading to corrosion.
- Aluminum polish may be used to polish small scratches and scuffs for **Stainless Steel finish.**
- Mild soap may be used to clean the product for both **Stainless Steel and Black finish.**

**FAQ's****1. Hardware's are not of correct size.**

*In GMC / Chevrolet truck model 2006 & up, customer needs to reuse the factory body bolts to install the bracket. If your vehicle is not GMC / Chevrolet 2006 & up, ensure that holes are not partially covered with any plastic grommet or rust? If it is, remove the plastic grommet & rust from the thread holes & re-try the installation.*

**2. Mounting Bracket are not getting Installed properly.**

*In some cases Illustration images shown in Installation manual may not be the exactly same as per actual vehicle images ,also if Driver / Passenger side mounting brackets are very identical in the design, suggest referring Parts Identification guide to avoid fitment issue.*

**3. Products are thumping / rattling after installation.**

*Ensure that all required mounting brackets / hardware's are installed & tighten correctly. Suggest using white lithium / regular grease between the metal to metal contact surfaces.*

**4. Side Bar is not aligning with vehicle / Step Pads are not aligning with vehicle doors.**

*Side bar may be interchanged or mounting brackets are not installed at the correct position in the vehicle. Refer Parts identification guide.*

**5. Missing / Excess Hardware.**

*Recheck hardware count as per the part list.*

**6. Product not installing properly.**

*Ensure make model year, cab length and bed size of your vehicle is listed in the application. All installation steps are followed correctly.*

**Check out these other TrailFX Products!!**

[www.TrailFX.com](http://www.TrailFX.com)

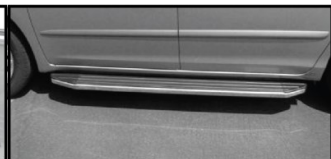
**BULL BAR****GRILLE GUARDS****BED RAILS****RUNNING BOARDS**

*Keystone Automotive Operations Inc. (KAO) warrants this product to be free of defects in material and workmanship at the time of purchase by the original retail consumer. KAO disclaims any other warranties, express or implied, including the warranty of fitness for a particular purpose or an intended use. If the product is found to be defective, KAO may replace or repair the product at our option, when the product is returned prepaid, with proof of purchase. Alteration to, improper installation, or misuse of this product voids the warranty. KAO's liability is limited to repair or replacement of products found to be defective, and specifically excludes liability for any incidental or consequential loss or damage.*