

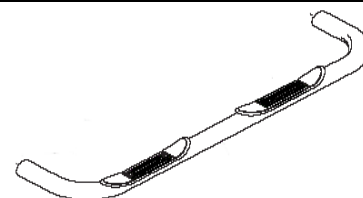

3" Side Bar

Part No. J030T



Fits: 2007 - Current Jeep Wrangler JK Unlimited (4 Door)

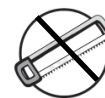

60-180 min

Cutting Not Required

Drilling Not Required



REMOVE CONTENTS FROM BOX. VERIFY ALL PARTS ARE PRESENT.



support@trailfx.com



READ INSTRUCTIONS CAREFULLY BEFORE STARTING INSTALLATION.



1 866 638 4870

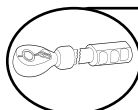

DO NOT OVER TORQUE. STANDARD OPERATING LOAD FOR TIGHTEN BODY MOUNT NUTS & BOLTS VARIES FROM 45 TO 65 FOOT POUND.



POLISHED STAINLESS STEEL – LIMITED LIFETIME
POWDER COATED BLACK – 3 YEARS

PARTS LIST:

Qty	Part Description	Qty	Part Description
1	Driver/Left Side Armor Assembly	6	8-1.25mm x 35mm Hex Bolts
1	Passenger/Right Side Armor Assembly	6	8mm Lock Washers
6	10mm Nut Plates	6	8mm x 28mm OD x 3mm Large Flat Washers
6	10-1.5mm x 35mm Hex Bolts	12	6-1.0mm x 25mm Hex Head Bolts
6	10mm Lock Washers	24	6mm ID x 22mm OD x 2mm Flat Washers
6	10mm x 34mm OD x 3mm Flat Washers	12	6mm Nylon Lock Nuts

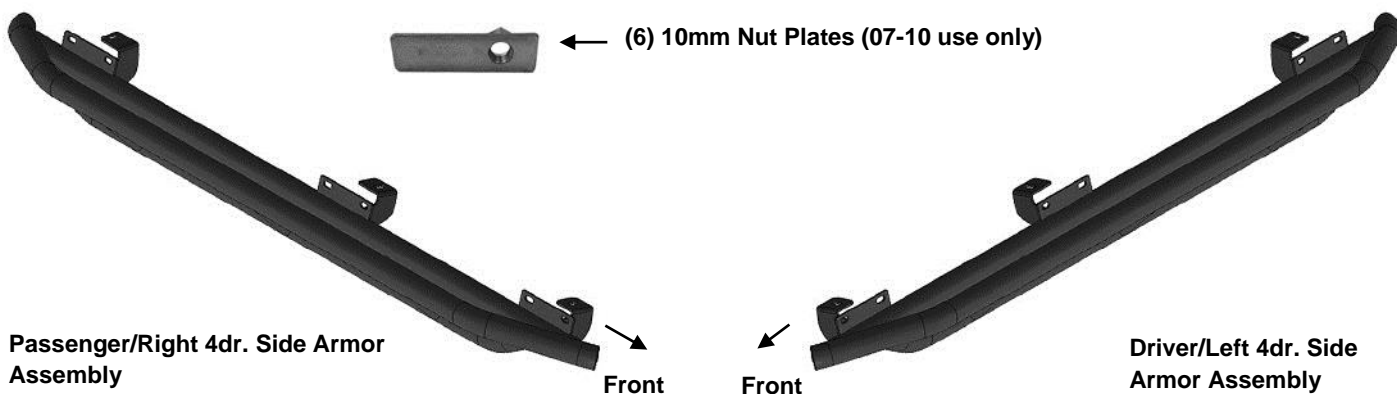

INSTALLATION PROCEDURE

FACTORY INSTALLED OR AFTERMARKET "ROCK RAILS," SIDE STEPS OR RUNNING BOARDS MUST BE REMOVED. ASSISTANCE IS HIGHLY RECOMMENDED.

1. Start installation on the passenger side of the vehicle. Locate the (3) factory pairs of mounting holes along the pinch weld, **(Figure 5)**. The mounting brackets on the Side Armor attach to the holes in the pinch weld and the small hole directly behind the pinch weld.
2. Determine if the vehicle has an open floor panel, **(2007-10, Figure 1)**, or threaded holes in the floor panel, **(2010-15, Figure 2)**, for the top tab on the Bracket.

Vehicles with open mounting locations along floor panel:

Move to the front pair of holes in the pinch weld. Locate the mid-point between the two holes, **(Figure 3)**. Insert (1) 10mm Nut Plate into the large square opening in the floor panel, **(Figures 4A & 4B)**. Line up the threaded nut with the small hole directly in line with the mid-point, **(Figure 3)**.

Repeat to install the 10mm Nut Plate as required in any/all locations.

Vehicles with factory threaded holes in floor panel: Skip to **Step 4**.

3. With assistance, hold the passenger Side Armor up in place against the back of the pinch weld. Line up the (3) brackets with the (6) factory holes in the pinch weld. Bolt the brackets to the **back** of the pinch weld with the included (6) 6mm x 25mm Hex Bolts, (12) 6mm Flat Washers and (6) 6mm Nylon Lock Nuts, **(Figures 5 & 6)**. Leave hardware loose at this time.
4. Bolt each top tab on the Side Armor to the vehicle:
 - a. Models with "open floor" requiring 10mm Nut Plate, attach each bracket to the Nut Plate with (1) 10mm x 35mm Hex Bolt, (1) 10mm Lock Washer and (1) 10mm Flat Washer, **(Figures 4B, 6 & 7)**. Repeat for any/all mounting locations.
 - b. Models with 8mm threaded factory holes, attach each bracket with (1) 8mm x 35mm Hex Bolt, (1) 8mm Lock Washer and (1) 8mm Flat Washer, **(Figures 2, 6 & 7)**. Repeat for any/all locations.
5. Level and adjust the Side Armor and tighten all hardware.
6. Repeat **Steps 2—6** for driver Side Armor installation.
7. Do periodic inspections to the installation to make sure that all hardware is secure and tight.

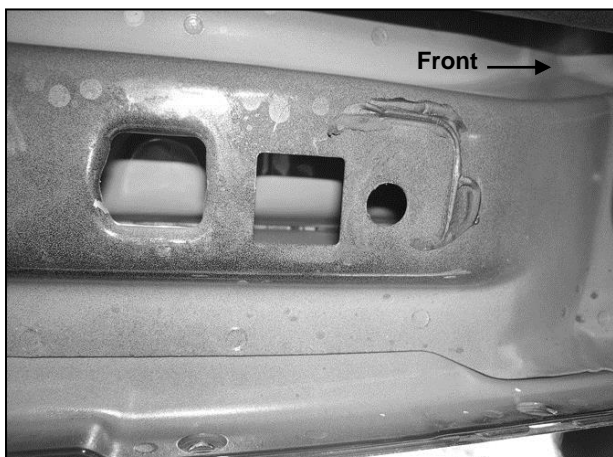

(Fig 1) 2007-10 driver side front mounting location

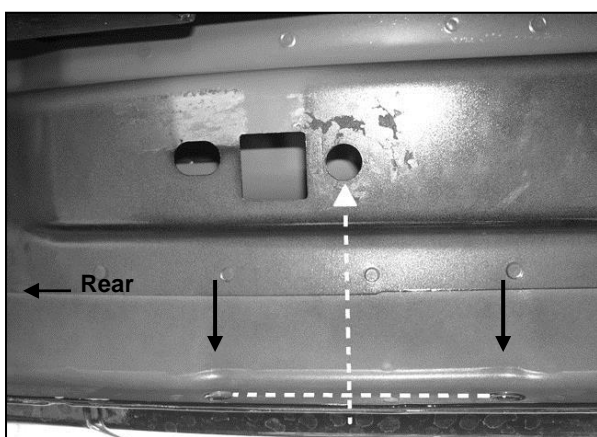

(Fig 3) 2007-10 driver side rear mounting location pictured from below. Locate the holes in the pinch weld first to determine correct mounting hole for 10mm Nut Plate

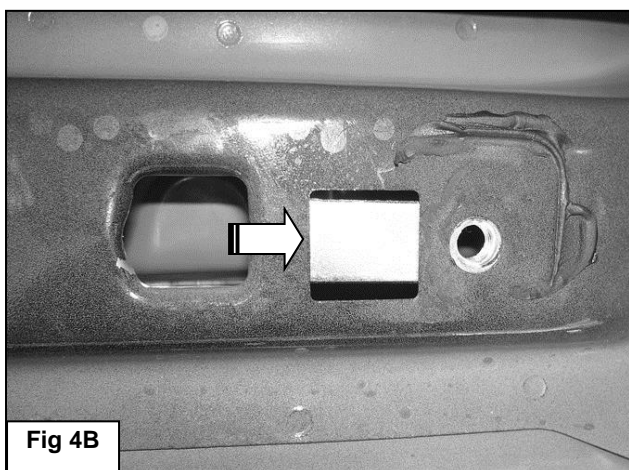
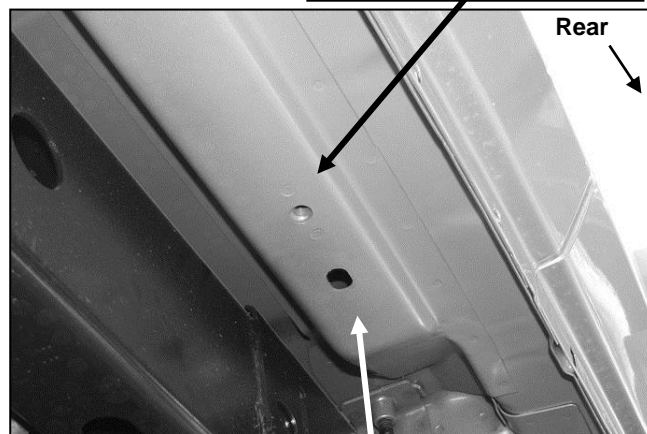
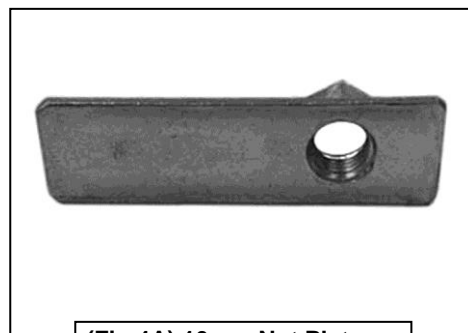

Fig 4B

Vehicles with threaded hole in body panel use:
8mm x 35mm Hex Bolt
8mm Lock Washer
8mm Flat Washer



(Fig 2) Example of 2010-15 "closed" floor panel with 8mm threaded hole-10mm Nut Plate not required



(Fig 4A) 10mm Nut Plate

(2) 6mm x 25mm Hex Bolts
(4) 6mm Flat Washers
(2) 6mm Nylon Lock Nuts

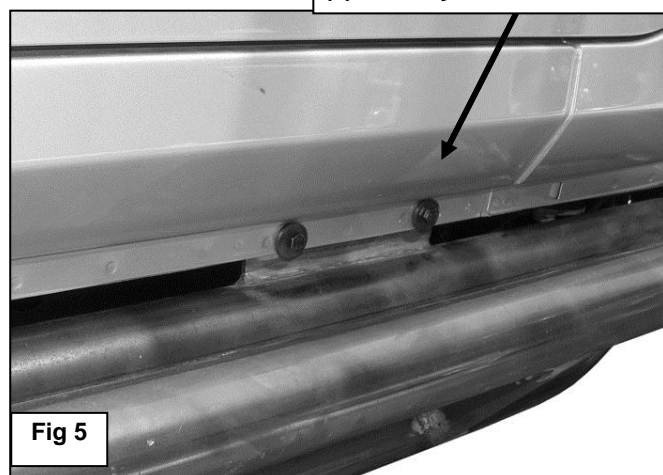
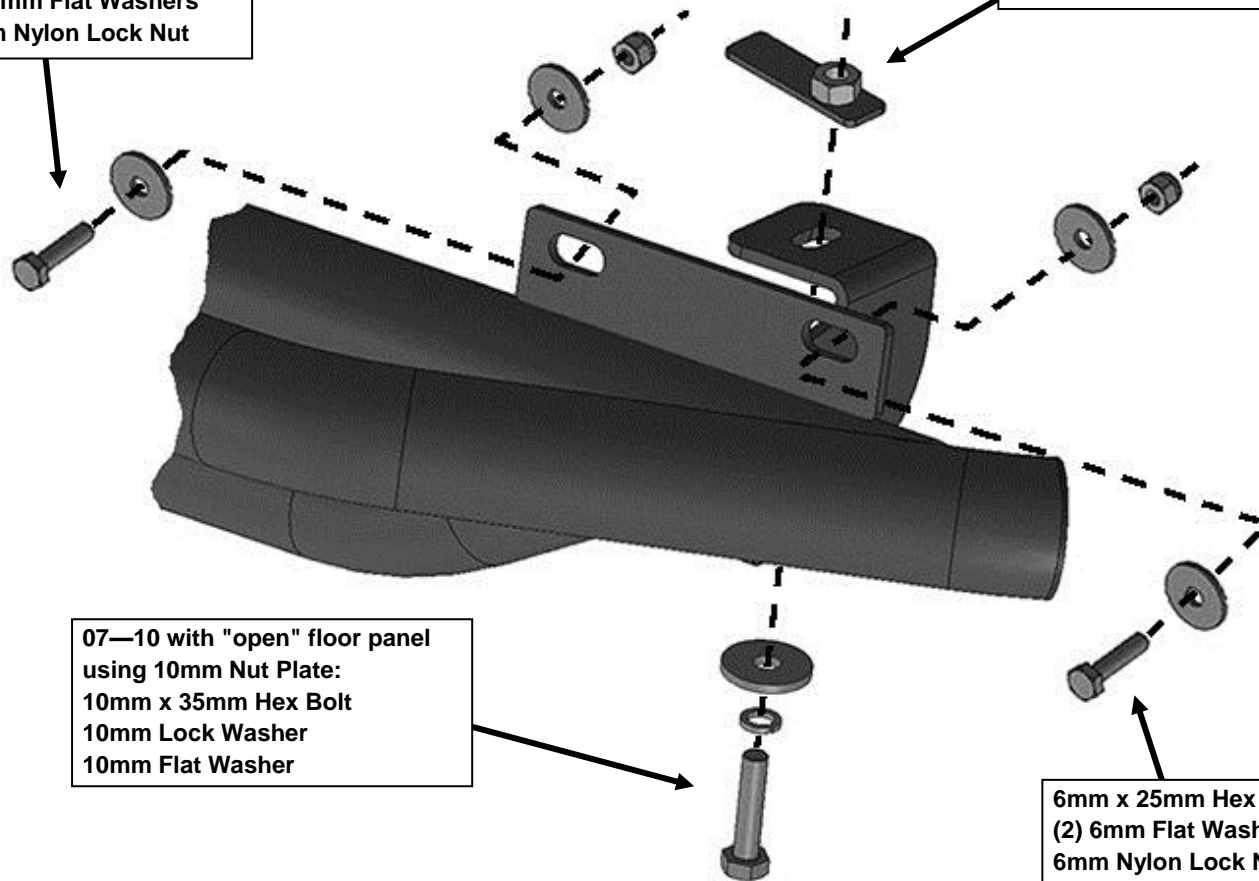

Fig 5

6mm x 25mm Hex Bolt
(2) 6mm Flat Washers
6mm Nylon Lock Nut

07—10 with "open" floor panel use 10mm Nut Plate



(Fig 6) Passenger side front installation illustrated



(Fig 7) Passenger rear installation pictured



PARTS IDENTIFICATION GUIDE

Driver Side tube packed using "Green" color foam sheet. Passenger Side tube packed using "White" color foam sheet

No.	Parts Identification
1	Passenger / Right 'Rear' Bracket marked "PR"
2	Driver / Left 'Rear' Bracket marked "DR"
3	Passenger / Right 'Center' Bracket marked "PC"
4	Driver / Left 'Center' Bracket marked "DC"
5	Passenger / Right 'Front' Bracket marked "PF"
6	Driver / Left 'Front' Bracket marked "DF"

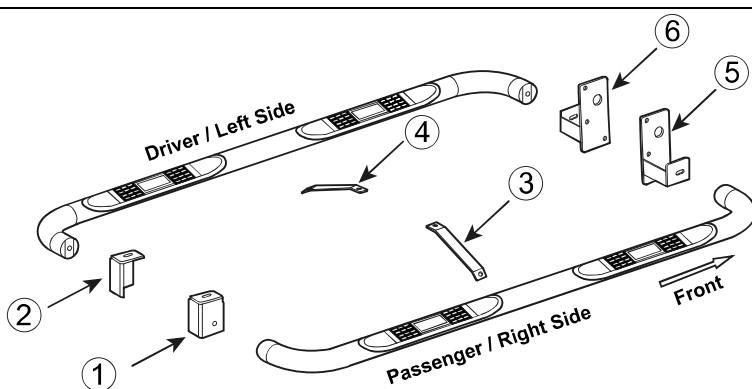

Note:

- This guide is to identify the parts and not a reference for part count.
- For part count, refer Parts List.
- Product / Bracket image is representative and actual design may vary.

PRODUCT CARE

- Periodically check the product to ensure all fasteners are tight and components are intact.
- Regular waxing is recommended to protect the finish of the product.
- **Use ONLY Non-Abrasive automotive wax.** Use of any soap, polish or wax that contains an abrasive is detrimental and can scratch the finish leading to corrosion.
- Aluminum polish may be used to polish small scratches and scuffs for **Stainless Steel finish.**
- Mild soap may be used to clean the product for both **Stainless Steel and Black finish.**

FAQ's

- 1. Hardware's are not of correct size.**
In GMC / Chevrolet truck model 2006 & up, customer needs to reuse the factory body bolts to install the bracket. If your vehicle is not GMC / Chevrolet 2006 & up, ensure that holes are not partially covered with any plastic grommet or rust? If it is, remove the plastic grommet & rust from the thread holes & re-try the installation.
- 2. Mounting Bracket are not getting Installed properly.**
In some cases Illustration images shown in Installation manual may not be the exactly same as per actual vehicle images ,also if Driver / Passenger side mounting brackets are very identical in the design, suggest referring Parts Identification guide to avoid fitment issue.
- 3. Products are thumping / rattling after installation.**
Ensure that all required mounting brackets / hardware's are installed & tighten correctly. Suggest using white lithium / regular grease between the metal to metal contact surfaces.
- 4. Side Bar is not aligning with vehicle / Step Pads are not aligning with vehicle doors.**
Side bar may be interchanged or mounting brackets are not installed at the correct position in the vehicle. Refer Parts identification guide.
- 5. Missing / Excess Hardware.**
Recheck hardware count as per the part list.
- 6. Product not installing properly.**
Ensure make model year, cab length and bed size of your vehicle is listed in the application. All installation steps are followed correctly.

Check out these other TrailFX Products!!

www.TrailFX.com

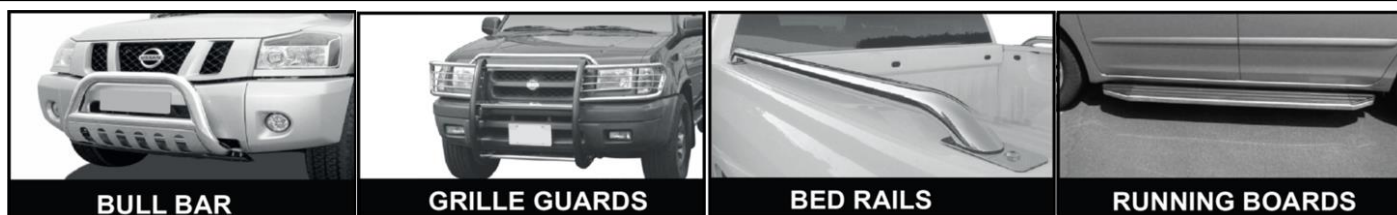

Keystone Automotive Operations Inc. (KAO) warrants this product to be free of defects in material and workmanship at the time of purchase by the original retail consumer. KAO disclaims any other warranties, express or implied, including the warranty of fitness for a particular purpose or an intended use. If the product is found to be defective, KAO may replace or repair the product at our option, when the product is returned prepaid, with proof of purchase. Alteration to, improper installation, or misuse of this product voids the warranty. KAO's liability is limited to repair or replacement of products found to be defective, and specifically excludes liability for any incidental or consequential loss or damage.