



Jeep Product

Part No. J053T

Fits: 2018-Current

Jeep Wrangler JL



REMOVE CONTENTS FROM BOX. VERIFY ALL PARTS ARE PRESENT.



READ INSTRUCTIONS CAREFULLY BEFORE STARTING INSTALLATION.

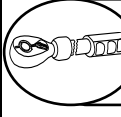

DO NOT OVER TORQUE. STANDARD OPERATING LOAD FOR TIGHTEN BODY MOUNT NUTS & BOLTS VARIES FROM 45 TO 65 FOOT POUND.



60-180 min



Cutting Not Required



Drilling Is Optional



support@trailfx.com



1 866 638 4870



POLISHED STAINLESS STEEL – LIMITED LIFETIME
POWDER COATED BLACK – 3 YEARS

PARTS LIST:

Qty	Part Description	Qty	Part Description
1	Driver/Left Rocker Guard Assembly	6	8mm x 28mm OD x 3mm Flat Washers
1	Passenger/Right Rocker Guard Assembly	12	6-1.0mm x 30mm Hex Bolts
6	8-1.25mm x 35mm Hex Bolts	24	6mm x 22mm OD x 2mm Flat Washers
6	8mm Lock Washers	12	6mm Nylon Lock Nuts

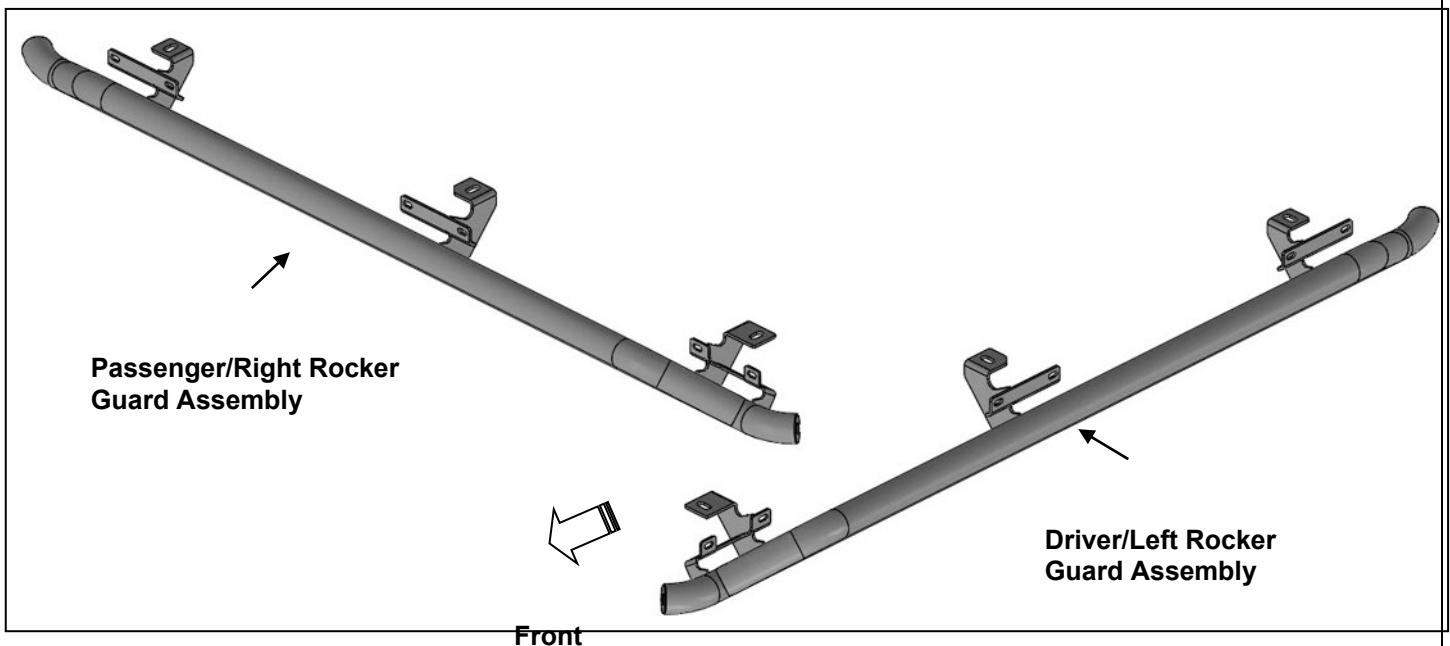

PROCEDURE:

- REMOVE CONTENTS FROM BOX. VERIFY ALL PARTS ARE PRESENT. READ INSTRUCTIONS CAREFULLY. FACTORY INSTALLED OR AFTERMARKET "ROCK RAILS," SIDE STEPS OR RUNNING BOARDS MUST BE REMOVED. ASSISTANCE IS HIGHLY RECOMMENDED.**
- Start installation on the driver side of the vehicle. Locate the (3) pairs of holes in the pinch weld. Directly behind each pair of holes, locate the 8mm threaded hole in the floor of the vehicle, (Figures 1—3). **NOTE:** Threaded holes may be covered with undercoating. Scrape off excess undercoating to provide a flat surface for brackets.

3. With assistance, attach the Rocker Guard to the **back** of the pinch weld using the included (6) 6mm x 25mm Hex Bolts, (12) 6mm Flat Washers and (6) 6mm Nylon Lock Nuts, (**Figures 4—9**). Leave hardware loose at this time.
4. Attach the mounting tabs on the Rocker Guard to the (3) threaded holes in the floor with the included (3) 8mm x 35mm Hex Bolts, (3) 8mm Lock Washers and (3) 8mm Flat Washers, (**Figures 4—9**).
5. Adjust the Rocker Guard and tighten all hardware.
6. Repeat **Steps 2—5** for passenger/right side Rocker Guard installation.
7. Do periodic inspections to the installation to make sure that all hardware is secure and tight.

Driver Side Installation Pictured

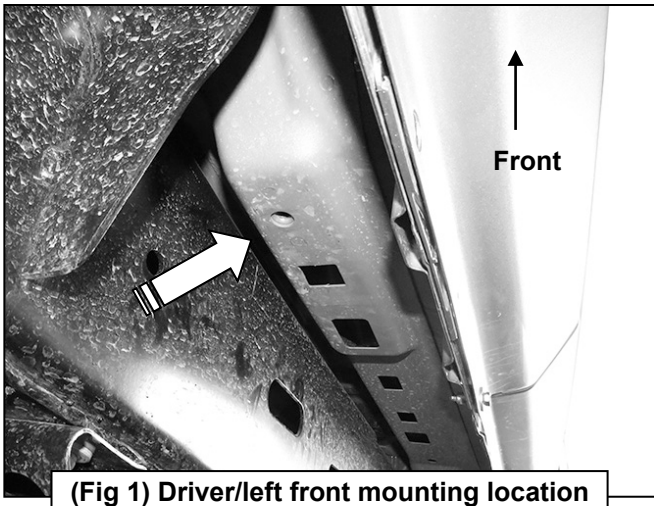

(Fig 1) Driver/left front mounting location

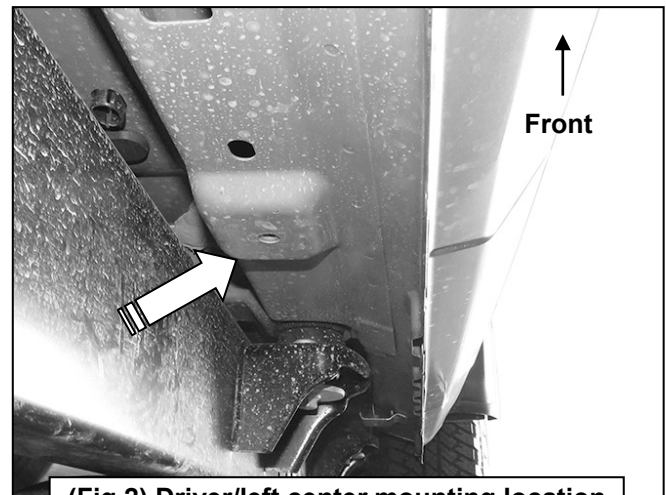

(Fig 2) Driver/left center mounting location

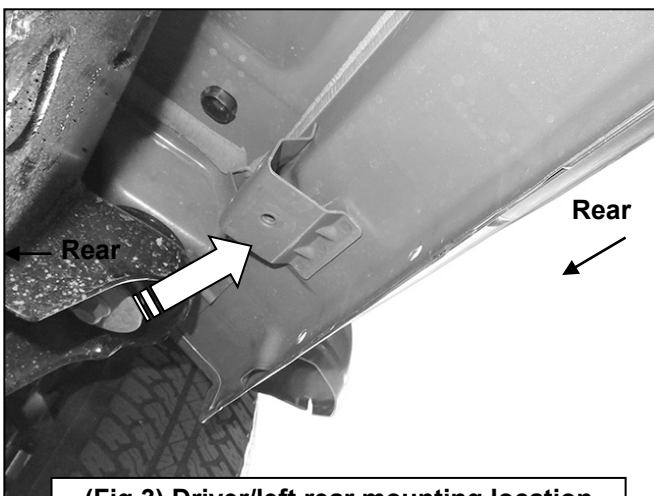

(Fig 3) Driver/left rear mounting location

- (2) 6mm Hex Bolts
- (4) 6mm Flat Washers
- (2) 6mm Nylon Lock Nuts

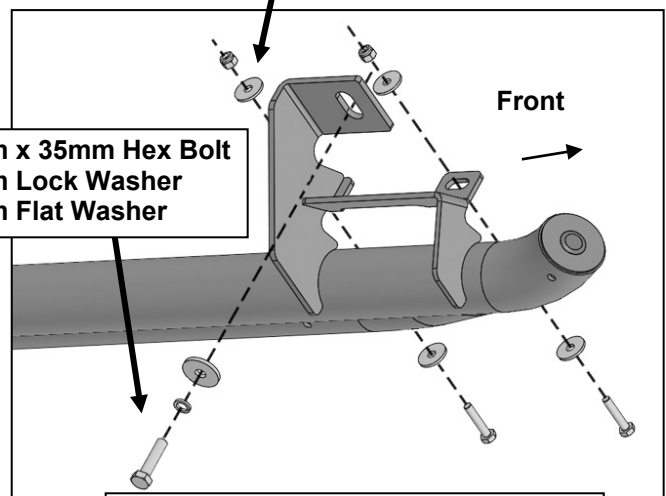

(Fig 4) Driver/left front installation

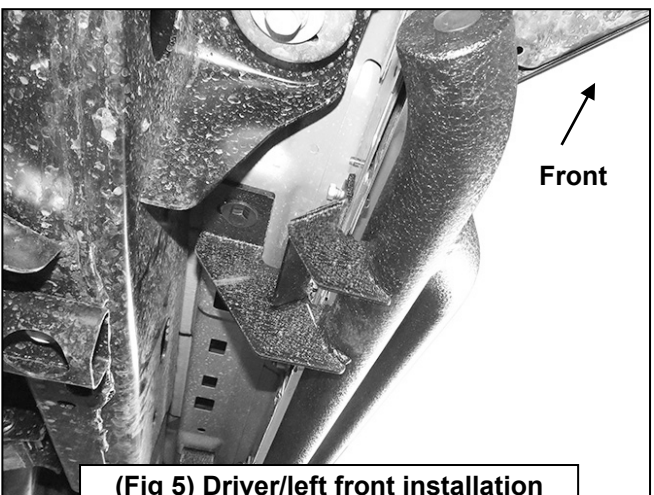

(Fig 5) Driver/left front installation

Driver Side Installation Pictured

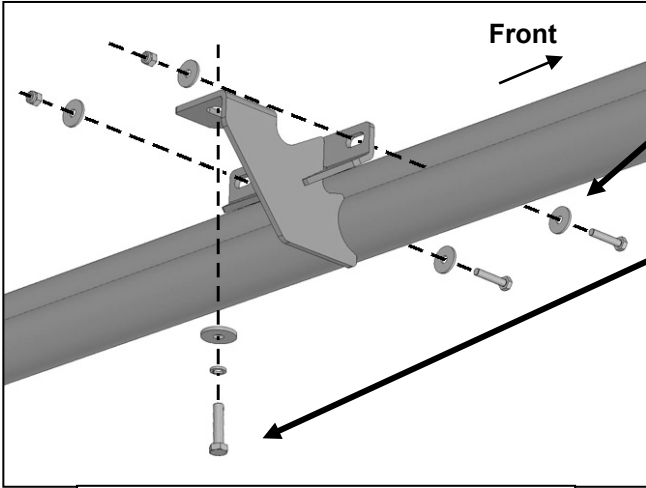

- (2) 6mm Hex Bolts
- (4) 6mm Flat Washers
- (2) 6mm Nylon Lock Nuts

- 8mm x 35mm Hex Bolt
- 8mm Lock Washer
- 8mm Flat Washer

(Fig 6) Driver/left center installation



(Fig 7) Driver/left center installation

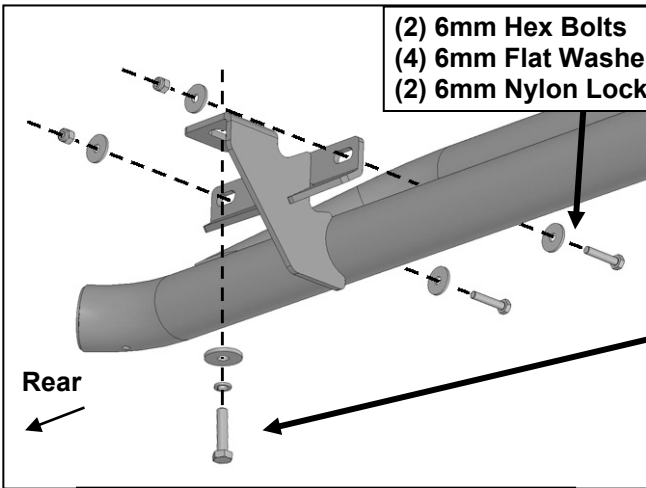

- (2) 6mm Hex Bolts
- (4) 6mm Flat Washers
- (2) 6mm Nylon Lock Nuts

- 8mm x 35mm Hex Bolt
- 8mm Lock Washer
- 8mm Flat Washer

(Fig 8) Driver/left rear installation

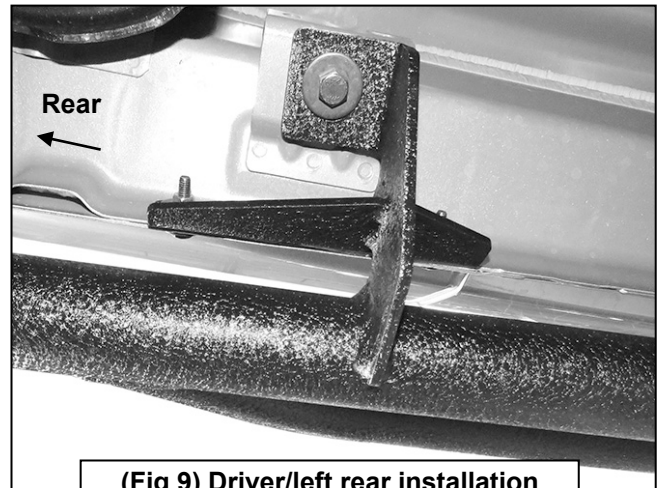

(Fig 9) Driver/left rear installation



1	Passenger / Right 'Rear' Bracket marked "PR"
2	Driver / Left 'Rear' Bracket marked "DR"
3	Passenger / Right 'Center' Bracket marked "PC"
4	Driver / Left 'Center' Bracket marked "DC"
5	Passenger / Right 'Front' Bracket marked "PF"
6	Driver / Left 'Front' Bracket marked "DF"

Note:

- This guide is to identify the parts and not a reference for part count.
- For part count, refer Parts List.
- Product / Bracket image is representative and actual design may vary.

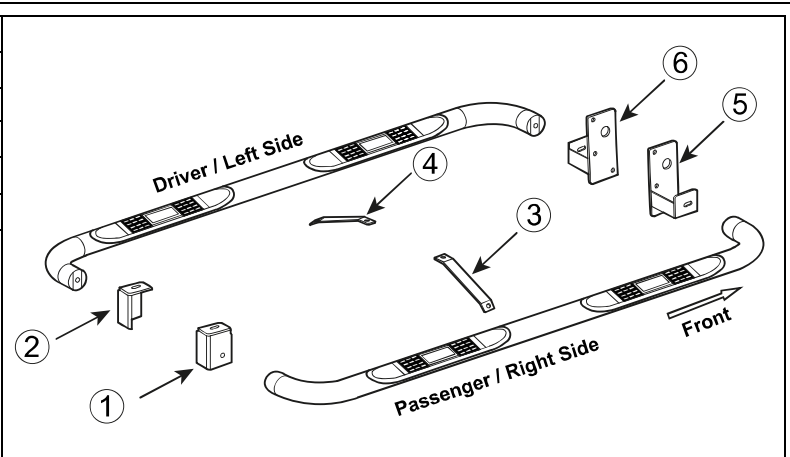

PRODUCT CARE

- Periodically check the product to ensure all fasteners are tight and components are intact.
- Regular waxing is recommended to protect the finish of the product.
- **Use ONLY Non-Abrasive automotive wax.** Use of any soap, polish or wax that contains an abrasive is detrimental and can scratch the finish leading to corrosion.
- Aluminum polish may be used to polish small scratches and scuffs for **Stainless Steel finish.**
- Mild soap may be used to clean the product for both **Stainless Steel and Black finish.**

FAQ's

1. **Hardware's are not of correct size.**
In GMC / Chevrolet truck model 2006 & up, customer needs to reuse the factory body bolts to install the bracket. If your vehicle is not GMC / Chevrolet 2006 & up, ensure that holes are not partially covered with any plastic grommet or rust? If it is, remove the plastic grommet & rust from the thread holes & re-try the installation.
2. **Mounting Bracket are not getting Installed properly.**
In some cases Illustration images shown in Installation manual may not be the exactly same as per actual vehicle images ,also if Driver / Passenger side mounting brackets are very identical in the design, suggest referring Parts Identification guide to avoid fitment issue.
3. **Products are thumping / rattling after installation.**
Ensure that all required mounting brackets / hardware's are installed & tighten correctly. Suggest using white lithium / regular grease between the metal to metal contact surfaces.
4. **Side Bar is not aligning with vehicle / Step Pads are not aligning with vehicle doors.**
Side bar may be interchanged or mounting brackets are not installed at the correct position in the vehicle. Refer Parts identification guide.
5. **Missing / Excess Hardware.**
Recheck hardware count as per the part list.
6. **Product not installing properly.**
Ensure make model year, cab length and bed size of your vehicle is listed in the application. All installation steps are followed correctly.

Check out these other TrailFX Products!!



BULL BAR

GRILLE GUARDS

BED RAILS

RUNNING BOARDS

Keystone Automotive Operations Inc. (KAO) warrants this product to be free of defects in material and workmanship at the time of purchase by the original retail consumer. KAO disclaims any other warranties, express or implied, including the warranty of fitness for a particular purpose or an intended use. If the product is found to be defective, KAO may replace or repair the product at our option, when the product is returned prepaid, with proof of purchase. Alteration to, improper installation, or misuse of this product voids the warranty. KAO's liability is limited to repair or replacement of products found to be defective, and specifically excludes liability for any incidental or consequential loss or damage.