



Running Board

Part No. R0002RB/R0007MK



Fits: 2010 - Current Lexus RX350



REMOVE CONTENTS FROM BOX. VERIFY ALL PARTS ARE PRESENT.



READ INSTRUCTIONS CAREFULLY BEFORE STARTING INSTALLATION.

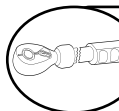

DO NOT OVER TORQUE. STANDARD OPERATING LOAD FOR TIGHTEN BODY MOUNT NUTS & BOLTS VARIES FROM 45 TO 65 FOOT POUND.



60-180 min

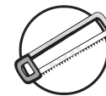

Cutting Required



Drilling Required



support@trailfx.com



1 866 638 4870



POLISHED STAINLESS STEEL – LIMITED LIFETIME
POWDER COATED BLACK – 3 YEARS

PARTS LIST:

Qty	Part Description	Qty	Part Description
1	Driver Side Running Board	4	10mm Plastic Retainer
1	Passenger Side Running Board	2	10mm x 50mm "T" Bolts (Rear Bracket only)
1	Driver Side Front Mounting Bracket	2	10mm x 35mm Button Head Bolt Plates
1	Passenger Side Front Mounting Bracket	4	10mm x 25mm Hex Bolts
1	Driver Side Center Mounting Bracket	2	10mm x 34mm x 3mm Large Flat Washers
1	Passenger Side Center Mounting Bracket	6	10mm x 27mm x 3mm STD Flat Washers
1	Driver Side Rear Mounting Bracket	4	10mm Lock Washers
1	Passenger Side Rear Mounting Bracket	4	10-1.5mm Serrated Flange Nuts Gr 8.8
1	10mm Insert Installing Tool	12	6mm x 20 mm "T" Bolts (Running Board)
1	6mm Insert Installing Tool	4	6-1.0mm x 25mm Hex Head Bolts
4	10-1.5mm Threaded Inserts	16	6mm x 22mm OD x 2mm Flat Washers
3	6-1.0mm Threaded Inserts	16	6mm Lock Washers
		12	6mm Hex Nuts

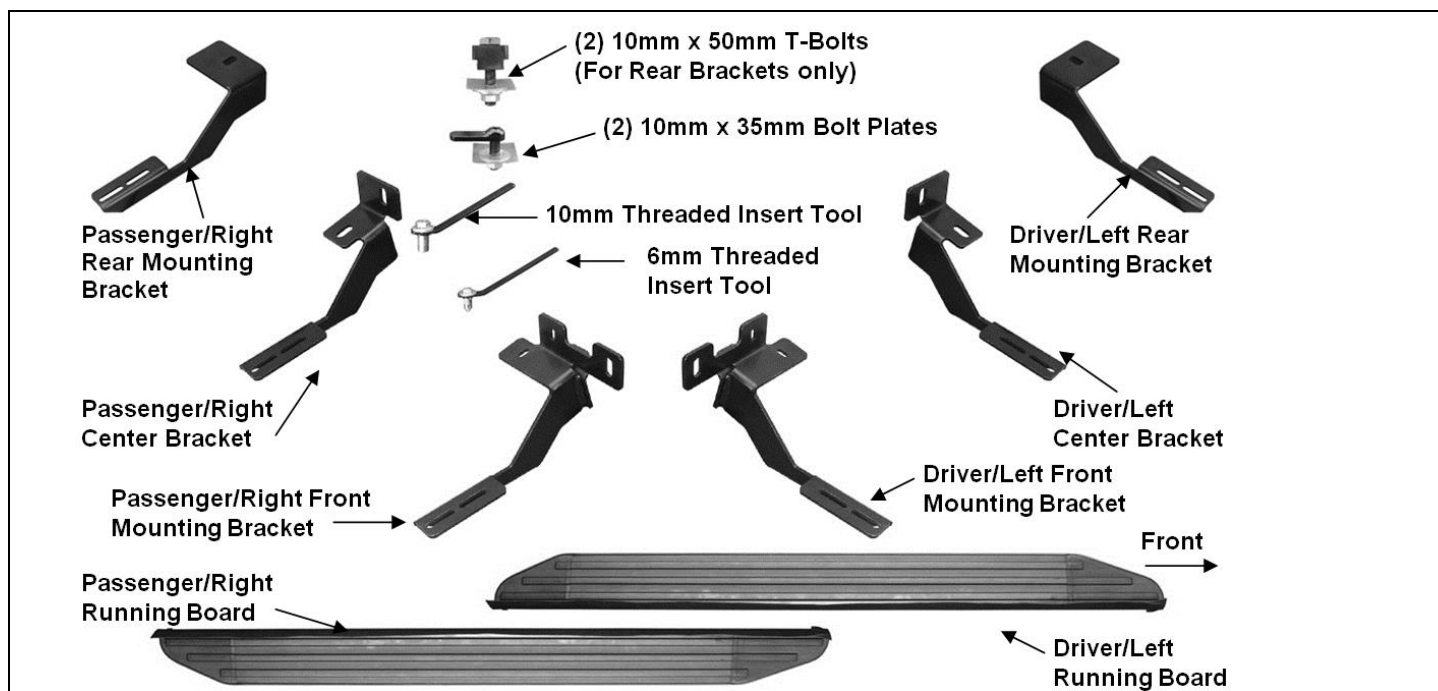

INSTALLATION PROCEDURE

1. Start installation under the driver side front of the vehicle. Remove the plastic covers, (**Fig. 1**). Pay close attention to the type and location of all factory hardware for reinstallation.
2. Locate the (2) factory holes in the inside wall of the floor panel, (**Fig. 1**). **NOTE:** The mounting locations may be covered by rubber plugs, sealant and/or undercoating. **IMPORTANT:** Scrape any excess sealant from body panel before installing any and all Brackets.

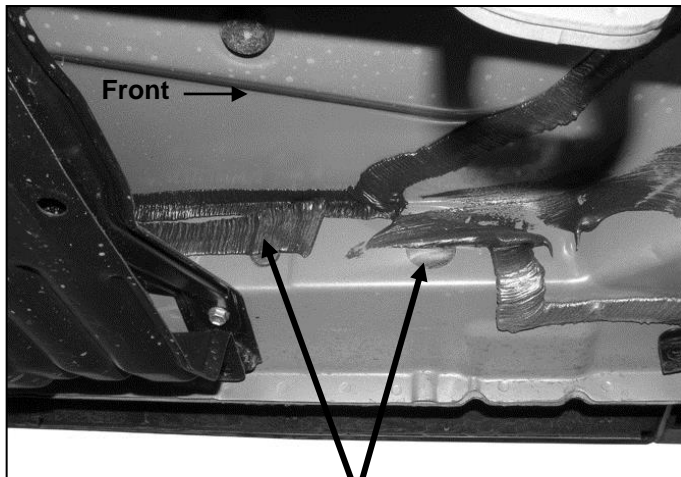

(Fig 1) Remove plastic cover. Remove rubber plugs in factory holes. NOTE: Driver side pictured

3. Select (1) 10mm Threaded Insert, (1) 10mm Insert Tool, (1) 10mm x 25mm Hex Bolt and (1) 10mm x 27mm STD Flat Washer. Assemble the Threaded Insert as pictured in **Figure 2**. Insert the Threaded Insert assembly into the forward, larger hole in the inner body panel, (**Fig. 4**). **NOTE:** If Insert fits too tight, enlarge hole by drilling with a 1/2" drill bit. **IMPORTANT:** Be careful not to enlarge hole too much. Insert should fit snug in hole and lip on Insert should be against sheet metal surface.
4. Hold the assembly in place by the handle on the Tool and apply pressure to keep the Insert in the hole. Tighten the Hex Bolt on the assembly until Insert is fully compressed/expanded and locked in place, (**Fig. 3**). **NOTE:** Do not over tighten or Insert failure or pull out may occur. Once the Threaded Insert is fully compressed, remove the Hex Bolt and Tool. Repeat **Steps 4 & 5** for all Threaded Insert installations.
5. Next, assemble (1) 6mm Threaded Insert and Tool as previously described. Insert the 6mm Threaded Insert assembly into the small hole 4" back from the first Insert installation in **Steps 4 & 5**.

Driver/left front Bracket installation:

Remove the 6mm factory hex bolt holding the bracket for the plastic cover up to the bottom of the frame channel, (**Fig. 4**). Select the driver side front Mounting Bracket. Slide the mounting tab on the Bracket under the factory bracket. Bolt the Mounting Bracket to the 10mm Threaded Insert with (1) 10mm x 25mm Hex Bolt, (1) 10mm Lock Washer, (1) 10mm x 27mm STD flat washer. Attach the Bracket to the 6mm Threaded Insert with (1) 6mm x 25mm Hex Bolt, (1) 6mm Lock Washer and (1) 6mm Flat Washer. Replace the factory 6mm bolt with (1) 6mm x 25mm Hex Bolt, (1) 6mm Lock Washer and (1) 6mm Flat Washer, (**Fig. 5**). Snug but do not fully tighten hardware at this time.

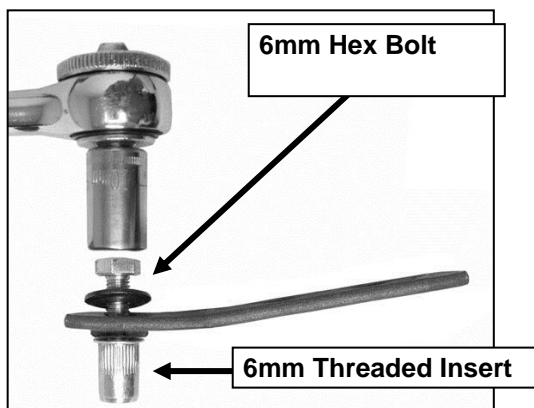

(Fig 2) 6mm Threaded Insert Tool assembly pictured

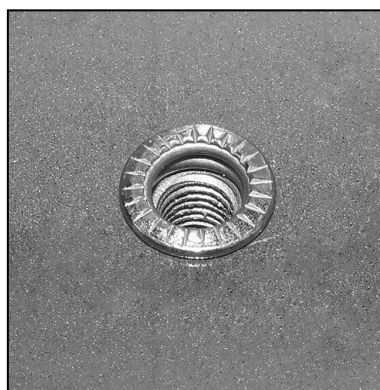

(Fig 3) Insert fully installed

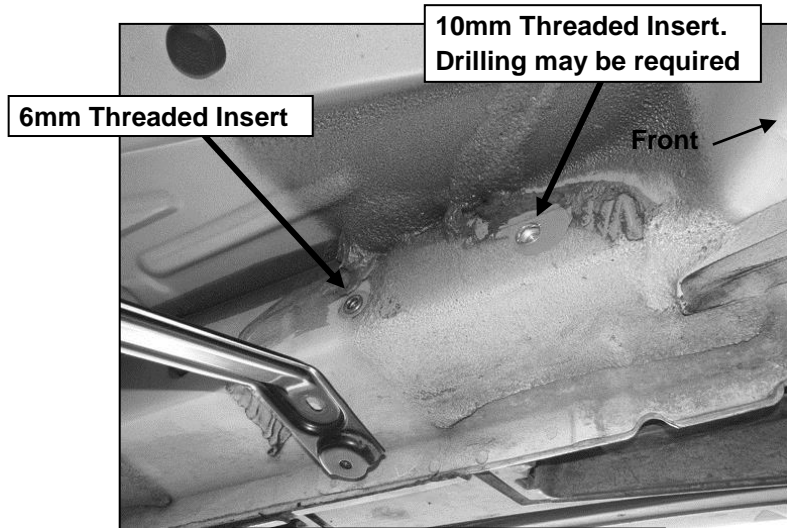

(Fig 4) Driver side front pictured

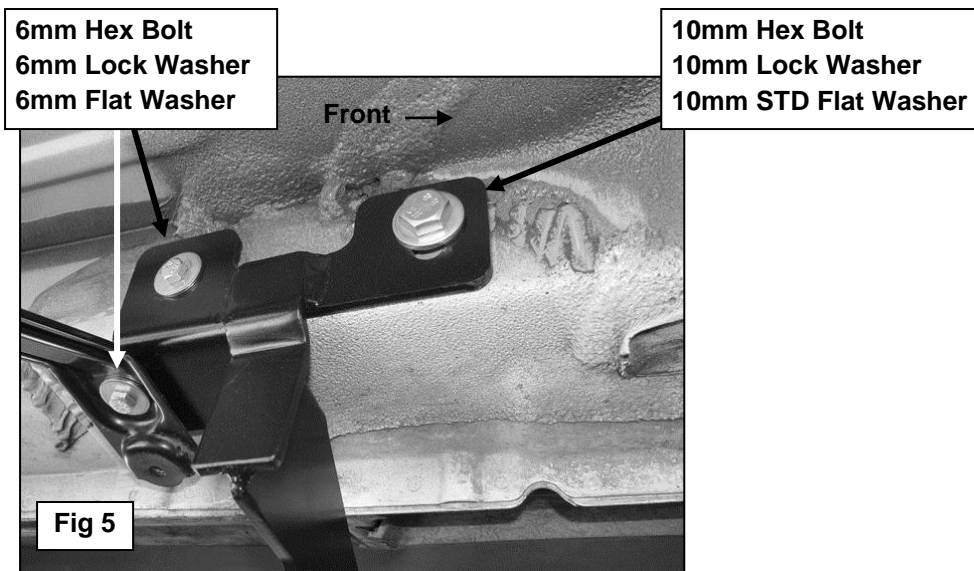
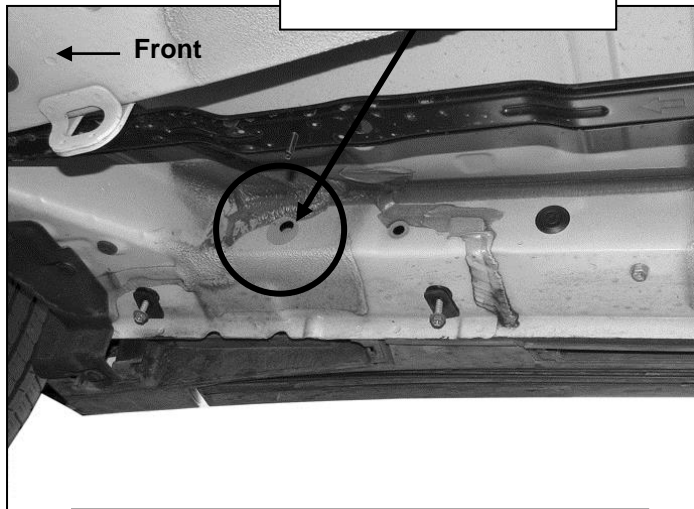

Fig 5

Passenger/right front Bracket installation:

Repeat **Steps 1 - 5** to install the Inserts for the passenger side front Bracket but note that there is no 6mm hex bolt on the bottom of the body panel, (**Fig. 6 & 7**). Install the passenger side front Bracket as previously described in driver side installation, (**Fig. 8**). Mark the location of the bottom mounting tab onto the bottom of the floor panel. Drill a 3/8" hole in the marked location. Install (1) 6mm Threaded Insert. Secure the bottom tab to the Threaded Insert with (1) 6mm x 25mm Hex Bolt, (1) 6mm Lock Washer and (1) 6mm Flat Washer, (**Fig. 9**).

NOTE: To insert a 10mm Threaded Insert into the large factory hole, check for fit and/or use 1/2" drill bit as necessary



(Fig 6) Passenger/Right side front pictured

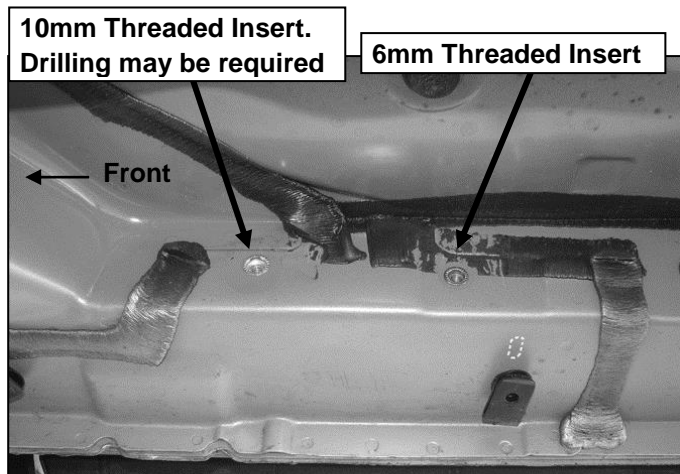

Fig 7

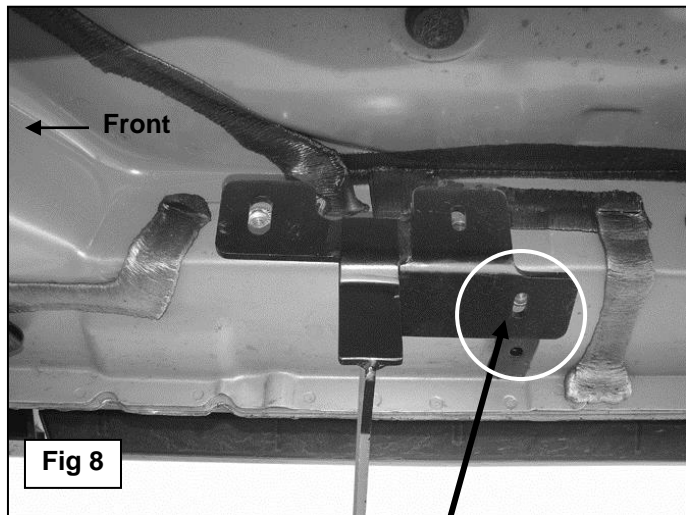
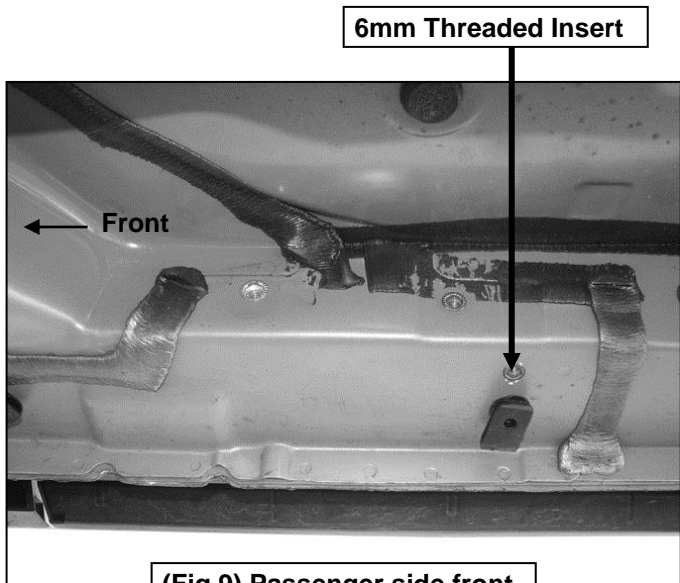

Fig 8

Bolt passenger side front Bracket in place. Mark location of slot on bottom of frame channel to drill for 6mm Threaded Insert (see Fig 7)



(Fig 9) Passenger side front mounting location pictured

6. Move to the center mounting location. Remove the plastic plug on the inside of the frame channel approximately 31-1/2" back along the floor panel from the front wheel opening, (Fig. 10B). Select (1) 10mm Button Head Bolt Plate and (1) 10mm Plastic Retainer, (Fig. 10A). Partially thread the Retainer onto the Bolt Plate. Insert the Bolt Plate into the factory hole, (Fig. 10B). Thread the Retainer down tight against the sheet metal. **IMPORTANT:** The Plastic Retainer is designed to prevent the Bolt Plate from falling into the body cavity and to aid Bracket installation.

Driver/left center Bracket installation:

Remove the plastic plug on the bottom of the floor panel. Select (1) 10mm Threaded Insert and assemble the insert tool, (Fig. 10B). Push the Insert into the hole in the bottom of the floor panel and install as previously described.

NOTE: It may be necessary to enlarge hole slightly as described in Step 4.

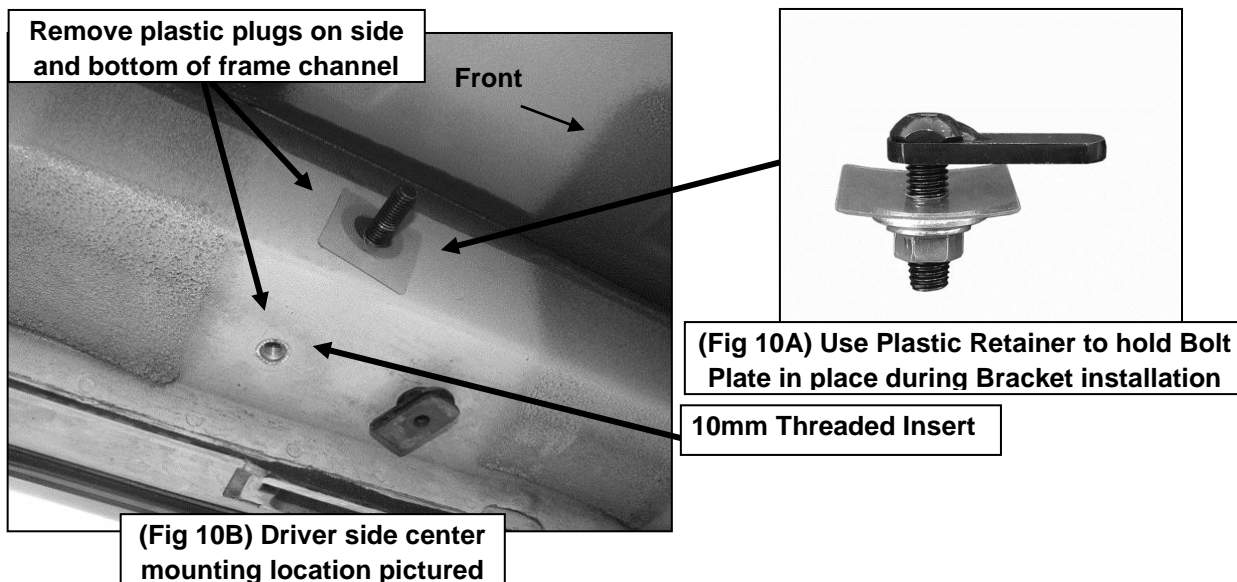

Hold the driver side center Mounting Bracket up in place and attach it to the Bolt Plate with (1) 10mm STD Flat Washer and (1) 10mm Flange Nut. Secure the Bracket to the 10mm Threaded Insert with (1) 10mm x 25mm Hex Bolt, (1) 10mm Lock Washer and (1) 10mm STD Flat Washer, (Fig. 11). Snug but do not fully tighten hardware at this time.

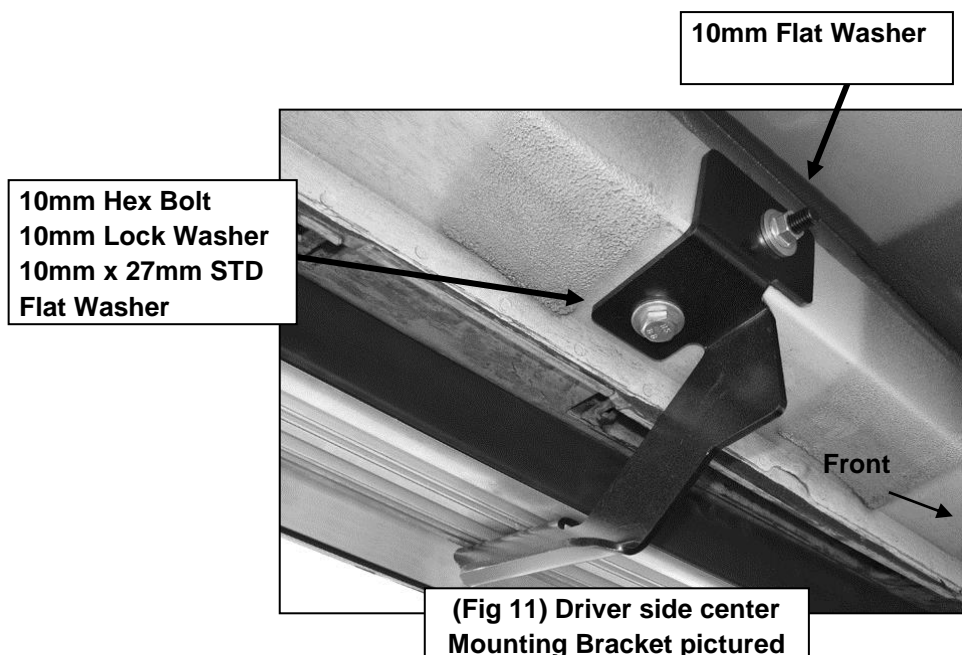

Passenger/right center Bracket installation:

Repeat **Step 6** to install the passenger side Center Bracket but note that there is no factory hole in the bottom of the frame channel, (similar to front Bracket install in **Step 6**). Bolt the Bracket to the Bolt Plate as previously described with the Bracket tight against the bottom of the frame channel, (**Fig. 12**). Mark the slot location onto the bottom of the channel, (**Fig. 13**). Remove the Center Bracket. Drill a 1/2" hole in the marked location. Install the 10mm Threaded Insert into the hole as previously described, (**Fig. 14**). Reinstall the Bracket. Bolt the Bracket to the 10mm Insert with (1) 10mm x 25mm Hex Bolt, (1) 10mm Lock Washer and (1) 10mm STD Flat Washer, (**Fig. 11**). Snug but do not tighten hardware.

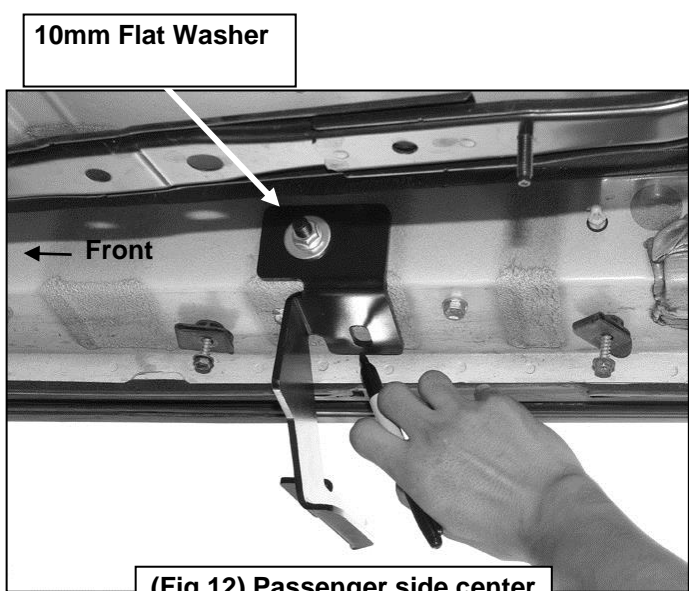

(Fig 12) Passenger side center mounting location pictured

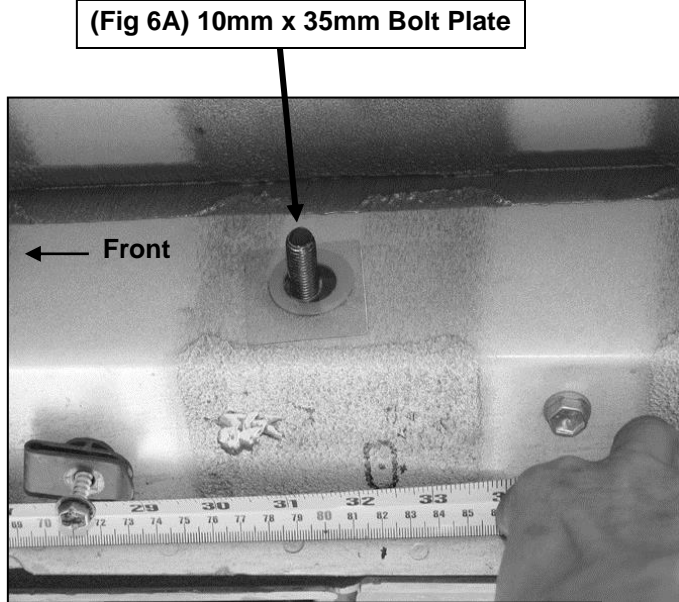

(Fig 13) Passenger/Right side center Bracket mounting location pictured

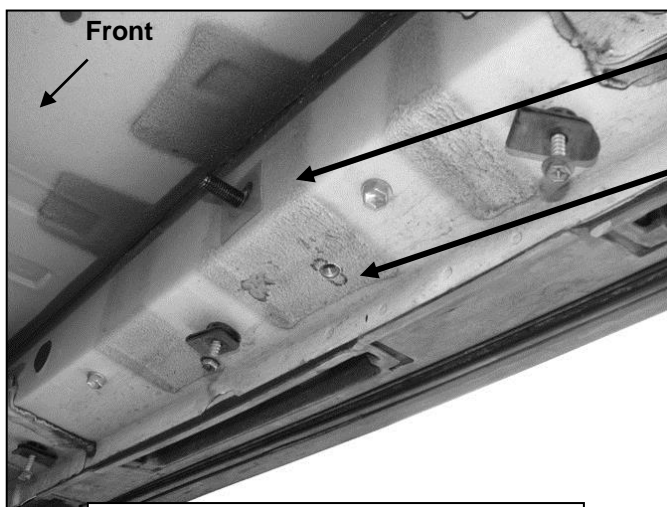

(Fig 14) Passenger/Right side center Bracket mounting location pictured

7. Move to the rear mounting location and locate the large oval hole in the floor panel, **(Fig. 15)**. Remove rubber plug. Select (1) 10mm T-Bolt and (1) 10mm Plastic Retainer, **(Fig. 16A)**. Partially thread the Retainer onto the T-Bolt. Insert the T-Bolt into the oval hole in the floor panel and rotate Bolt 90-degrees so that the Block is across the oval hole, **(Fig. 16B)**. Thread the Retainer down until it is tight against the floor panel, **(Fig. 17)**. Select the driver side rear Mounting Bracket. Secure the Bracket to the T-Bolt with (1) 10mm x 34mm Large Flat Washer and (1) 10mm Flange Nut, **(Fig. 18)**. Snug but do not fully tighten hardware at this time.

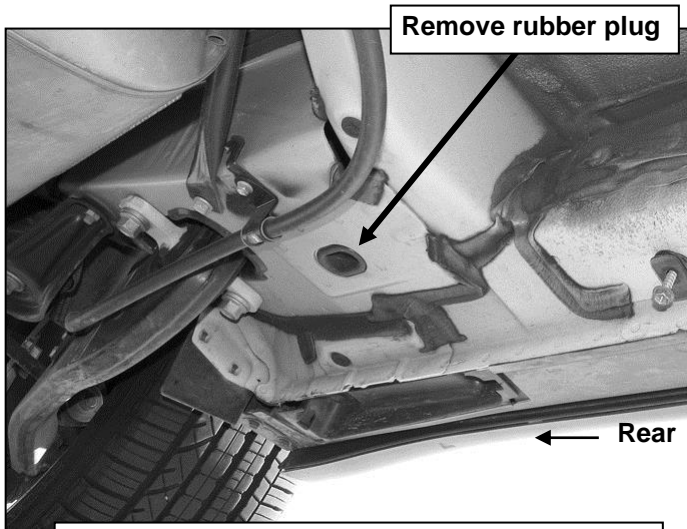

(Fig 15) Driver side rear mounting location



(Fig 16A) 10mm T-Bolt

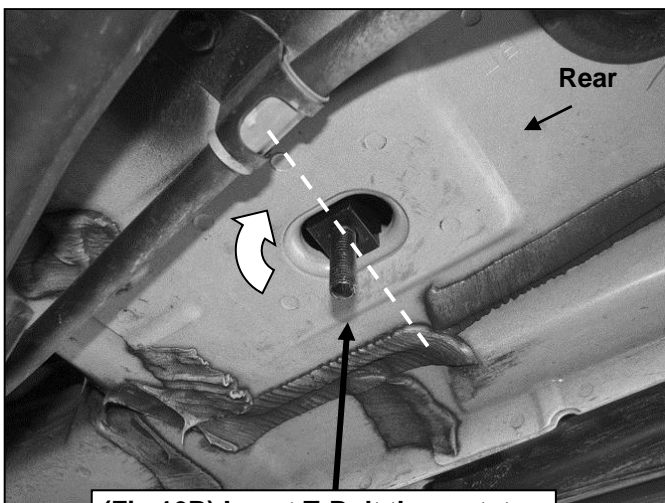

(Fig 16B) Insert T-Bolt then rotate 90-degrees to go across oval hole

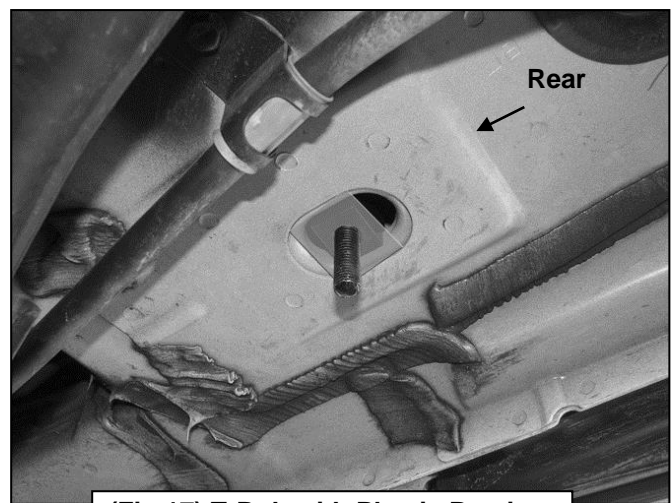

(Fig 17) T-Bolt with Plastic Retainer

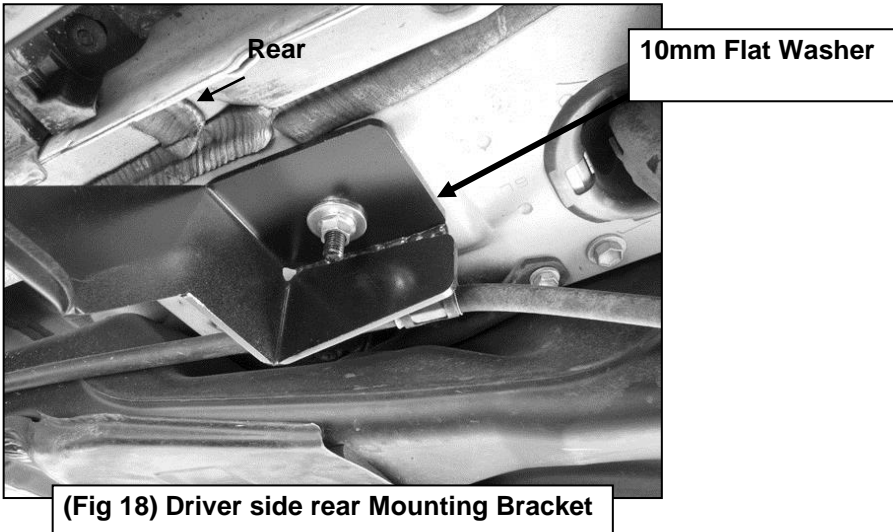

- Carefully unwrap and select the driver side Running Board. Insert (3) 6mm T-Bolts into each slot in the end of the channels, (3 T-Bolts per channel), on the bottom of the Running Board, (Fig. 19). Hold the Running Board up in approximate position and slide the T-Bolts down to line up with the (3) Mounting Brackets. Tilt the Board up at a slight angle and push back against the vehicle until the T-Bolts fit into the slots on the Brackets. Secure the Board to the Brackets with (6) 6mm Flat Washers, (6) 6mm Lock Washers and (6) 6mm Hex Nuts, (Fig. 20). Do not tighten hardware at this time. **NOTE:** the Running Board is designed to fit close to the vehicle. It may be necessary to temporarily loosen the Bracket hardware and tilt the Brackets downward to insert the Running Board.

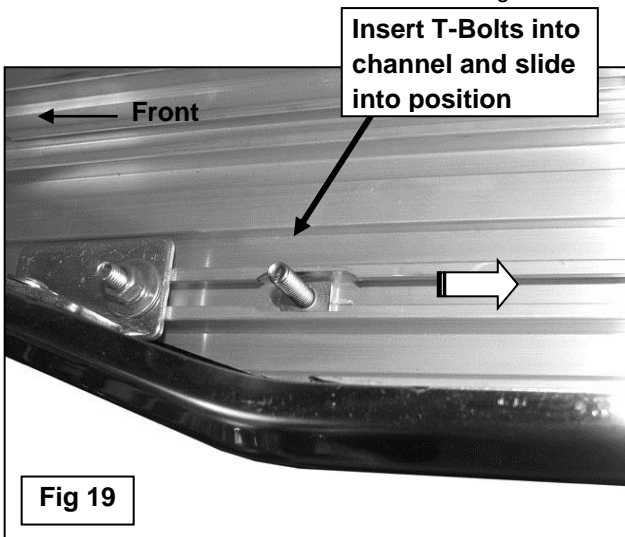

9. Level and adjust the Running Board as desired and tighten all hardware, (Fig. 21). Once all hardware has been tightened, hold the plastic covers removed in Step 2, up in position, (Fig. 22A & 22B). Trace the location of the front and center Brackets onto the covers, (Fig. 23A & 24A). Carefully cut the plastic covers to clear the Brackets, (Fig. 23B & 24B). **IMPORTANT:** Cut as little as possible from the covers. Reinstall the plastic covers with factory hardware. Tighten all hardware.



(Fig 21) Driver side complete installation

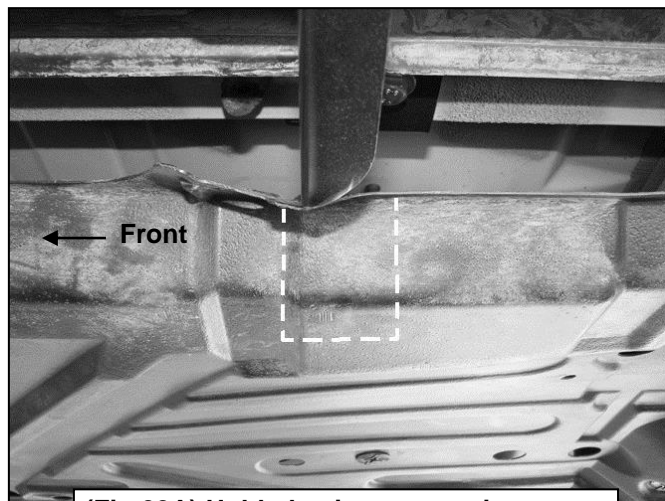

(Fig 22A) Hold plastic cover up in position to determine area to cut from cover. Driver side middle cover pictured



(Fig 22B) Hold plastic cover up in position to determine area to cut from cover. Driver side front cover pictured

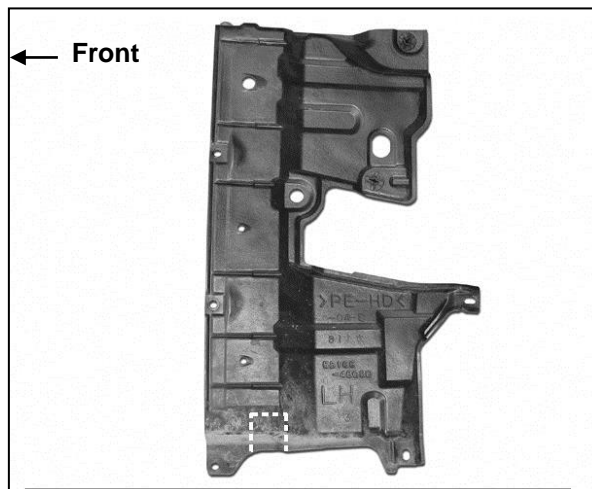

(Fig 23A) Driver side front cover pictured

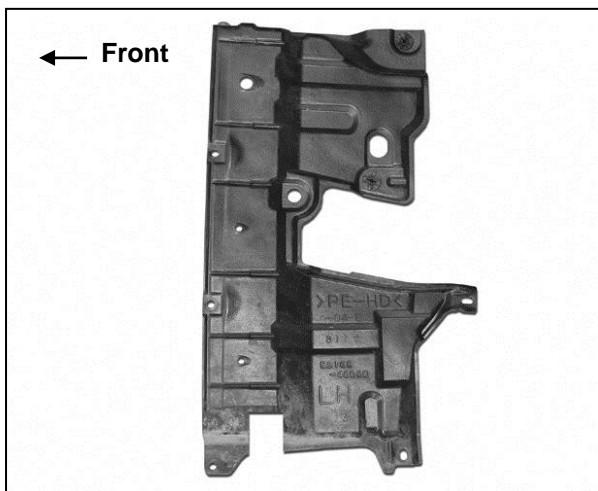

(Fig 23B) Cut cover only enough to clear Bracket. Cut shown for example only

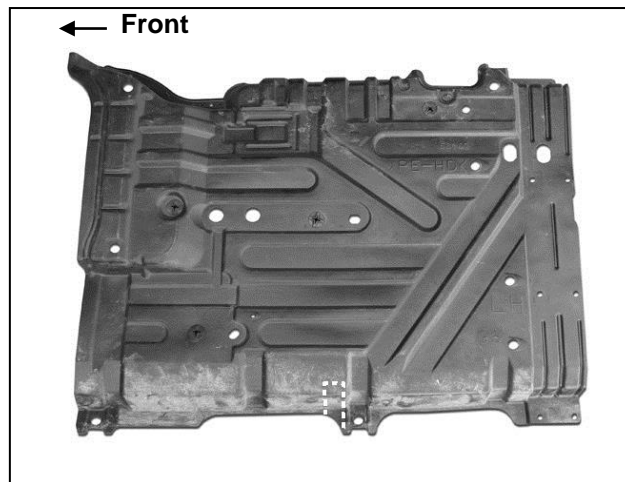

(Fig 24A) Driver side middle cover

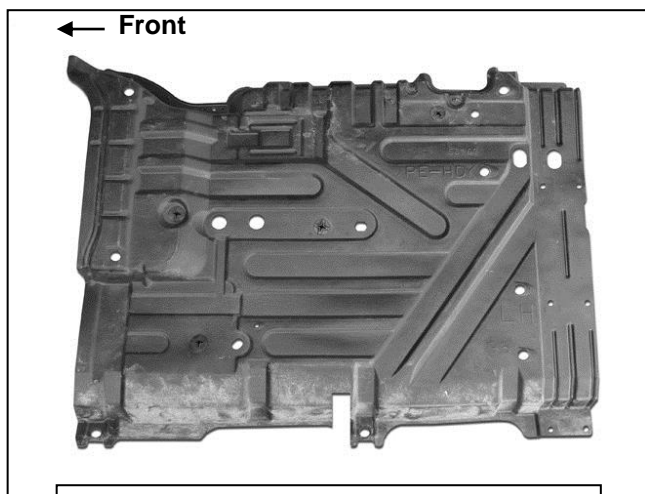

(Fig 24B) Cut cover only enough to clear Bracket. Cut shown for example only

10. Repeat **Steps 1 – 9** for passenger side Running Board installation.

PRODUCT CARE

- Periodically check the product to ensure all fasteners are tight and components are intact.
- Regular waxing is recommended to protect the finish of the product.
- **Use ONLY Non-Abrasive automotive wax.** Use of any soap, polish or wax that contains an abrasive is detrimental and can scratch the finish leading to corrosion.
- Aluminum polish may be used to polish small scratches and scuffs for **Stainless Steel finish.**
- Mild soap may be used to clean the product for both **Stainless Steel and Black finish.**

FAQ's**1. Hardware's are not of correct size.**

In GMC / Chevrolet truck model 2006 & up, customer needs to reuse the factory body bolts to install the bracket. If your vehicle is not GMC / Chevrolet 2006 & up, ensure that holes are not partially covered with any plastic grommet or rust? If it is, remove the plastic grommet & rust from the thread holes & re-try the installation.

2. Mounting Bracket are not getting Installed properly.

In some cases Illustration images shown in Installation manual may not be the exactly same as per actual vehicle images ,also if Driver / Passenger side mounting brackets are very identical in the design, suggest referring Parts Identification guide to avoid fitment issue.

3. Products are thumping / rattling after installation.

Ensure that all required mounting brackets / hardware's are installed & tighten correctly. Suggest using white lithium / regular grease between the metal to metal contact surfaces.

4. Side Bar is not aligning with vehicle / Step Pads are not aligning with vehicle doors.

Side bar may be interchanged or mounting brackets are not installed at the correct position in the vehicle. Refer Parts identification guide.

5. Missing / Excess Hardware.

Recheck hardware count as per the part list.

6. Product not installing properly.

Ensure make model year, cab length and bed size of your vehicle is listed in the application. All installation steps are followed correctly.

Check out these other TrailFX Products!!

www.TrailFX.com



SIDE BAR

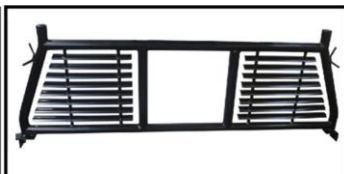

HEADACHE RACKS



HD GRILLE GUARDS



ROCKER GUARDS

Keystone Automotive Operations Inc. (KAO) warrants this product to be free of defects in material and workmanship at the time of purchase by the original retail consumer. KAO disclaims any other warranties, express or implied, including the warranty of fitness for a particular purpose or an intended use. If the product is found to be defective, KAO may replace or repair the product at our option, when the product is returned prepaid, with proof of purchase. Alteration to, improper installation, or misuse of this product voids the warranty. KAO's liability is limited to repair or replacement of products found to be defective, and specifically excludes liability for any incidental or consequential loss or damage.