



Running Board

Part No. R0016MK/R0005RB

Fits: 2007 - 2009
2007 - Current
2007 - Current
2007 - 2010

Buick Enclave
Chevy Traverse
GMC Acadia (Excl. Denali)
Saturn Outlook

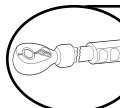

REMOVE CONTENTS FROM BOX. VERIFY ALL PARTS ARE PRESENT.

READ INSTRUCTIONS CAREFULLY BEFORE STARTING INSTALLATION.

DO NOT OVER TORQUE. STANDARD OPERATING LOAD FOR TIGHTEN BODY MOUNT NUTS & BOLTS VARIES FROM 45 TO 65 FOOT POUND.



60-180 min



Cutting Not Required



Drilling Not Required



support@trailfx.com



1 866 638 4870



POLISHED STAINLESS STEEL – LIMITED LIFETIME
 POWDER COATED BLACK – 3 YEARS

PARTS LIST:

Qty	Part Description	Qty	Part Description
1	Driver/Left Running Board	8	10mm Lock Washers
1	Passenger/Right Running Board	4	10-1.5mm Hex Nuts
2	Driver/Left Mounting Brackets (front & rear same)	4	8-1.25mm x 30mm Hex Bolts
2	Passenger/Right Mounting Brackets (front & rear same)	4	8mm x 22mm OD x 2mm Flat Washers
2	Center Mounting Brackets (driver & pass same)	4	8mm Lock Washers
2	10-1.50mm Double Nut Plates	12	6-1.0mm x 20mm T-Bolts
4	10mm x 35mm L-Bolt/8mm Nut Plates	12	6mm x 22mm OD x 2mm Flat Washers
4	10mm Plastic Retainers	12	6mm Lock Washers
4	10-1.50mm x 35mm Hex Bolts	12	6-1.0mm Hex Nuts
8	10mm x 27mm OD x 3mm Flat Washers		

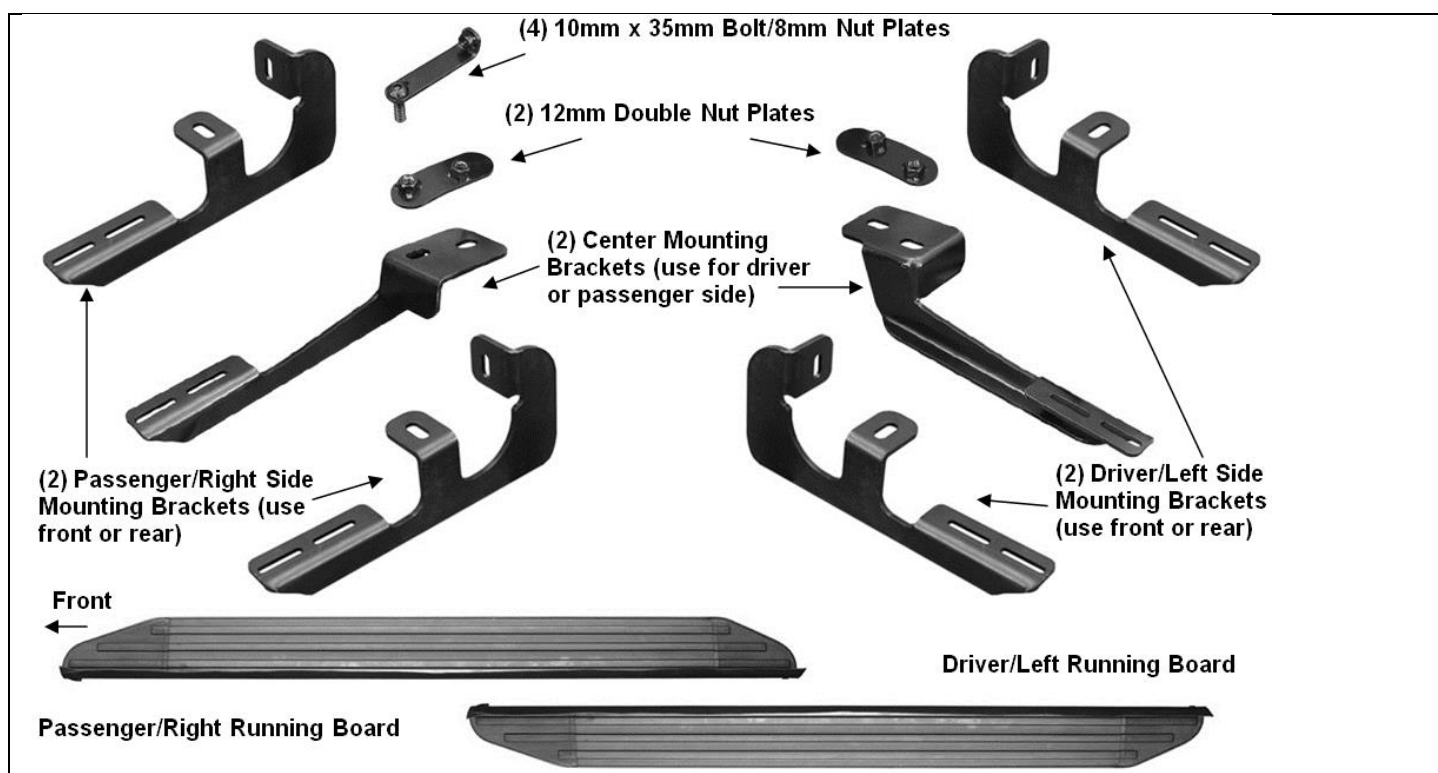

INSTALLATION PROCEDURE

1. Start installation on the driver side. Locate the factory holes in the bottom and inside of the floor panel towards the front tire opening, **(Figure 1)**. **IMPORTANT:** On some vehicles, the body panel may be filled with expanding foam insulation. Use a long flat blade screwdriver or heavy wire, (coat hanger for example), to dig out the foam to provide clearance for the L-Bolt/Nut Plates, **(Figure 2)**.

Use these (2) holes. Remove foam as necessary

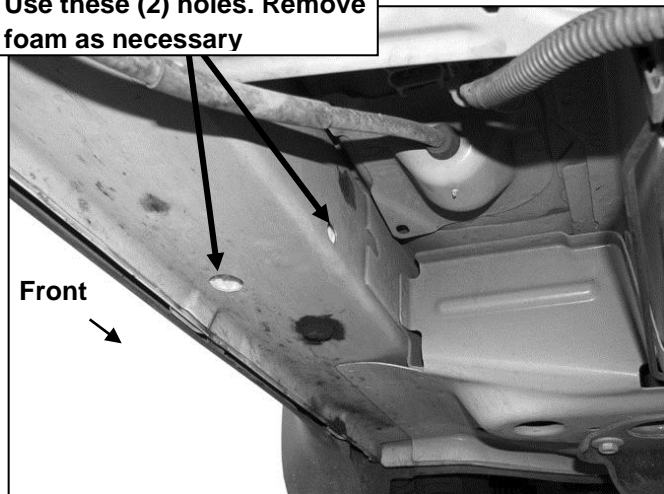

(Fig 1) Driver side front mounting location

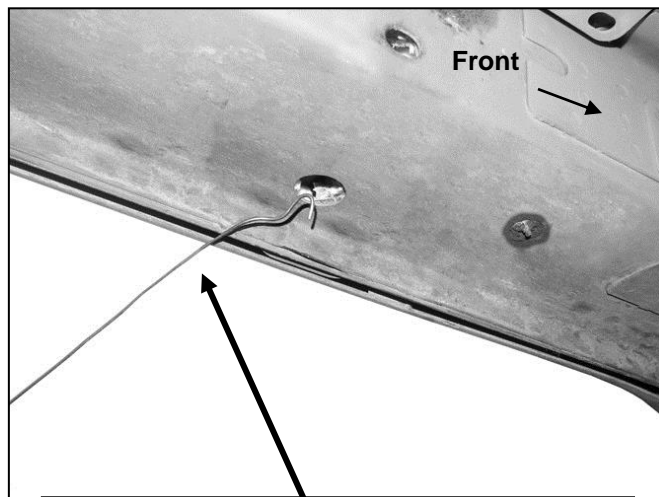

(Fig 2) Use wire to pull foam from floor panel

2. Select (1) 10mm L-Bolt/Nut Plate, **(Figure 3A)**. Insert the bent end with the 8mm nut into the hole in the bottom of the floor panel, **(Figure 3B)**. Line up the hex nut with the hole in the side of the floor panel. Thread (1) 10mm Plastic Retainer onto the 10mm Bolt end of the Bolt/Nut Plate, **(Figure 3B)**. **NOTE:** The Plastic Retainer is provided to help hold the Bolt/Nut Plate in position during Bracket installation.

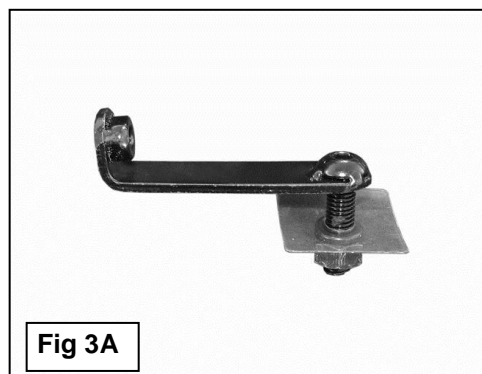

Fig 3A

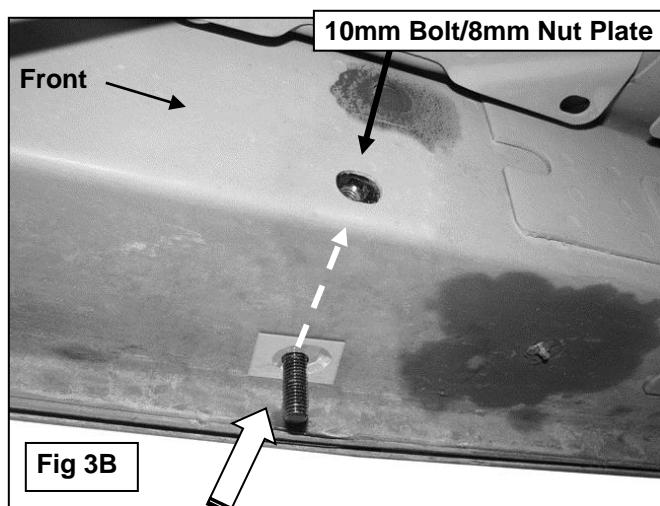
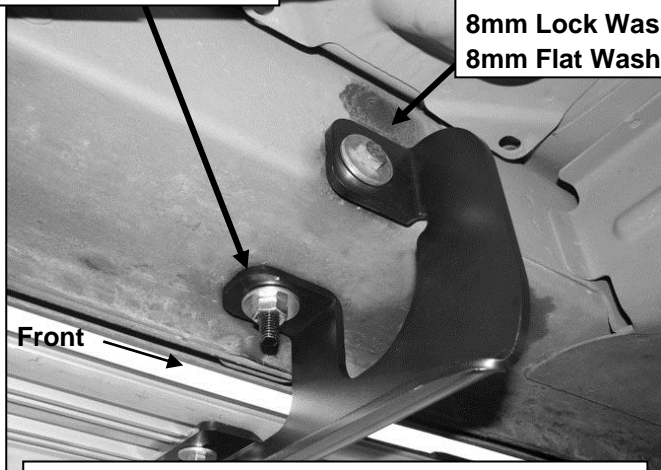

Fig 3B

3. Select (1) driver side Mounting Bracket. Position the Bracket up to the vehicle and over the previously installed 10mm Bolt/Nut Plate, **(Figure 4)**. Attach the Bracket to the Bolt/Nut Plate with (1) 10mm Flat Washer, (1) 10mm Lock Washer and (1) 10mm Hex Nut. Attach the Bracket to the 8mm Nut with (1) 8mm x 30mm Hex Bolt, (1) 8mm Lock Washer and (1) 8mm Flat Washer. Do not tighten hardware at this time.

10mm Flat Washer
10mm Lock Washer
10mm Hex Nut

8mm x 30mm Hex Bolt
8mm Lock Washer
8mm Flat Washer



(Fig 4) Driver front Bracket installation pictured

- 4. Move along the floor panel to the center of the vehicle, (Figure 5). Select (1) 10mm Double Nut Plate, (Figure 6A). Insert the Nut Plate into the large hole in the floor panel reinforcement, (Figure 6B). Line up the threaded hole with the single small hole in the reinforcement, (Figure 7). NOTE: The Nut Plate is offset to line up with the offset holes in the floor panel reinforcement.

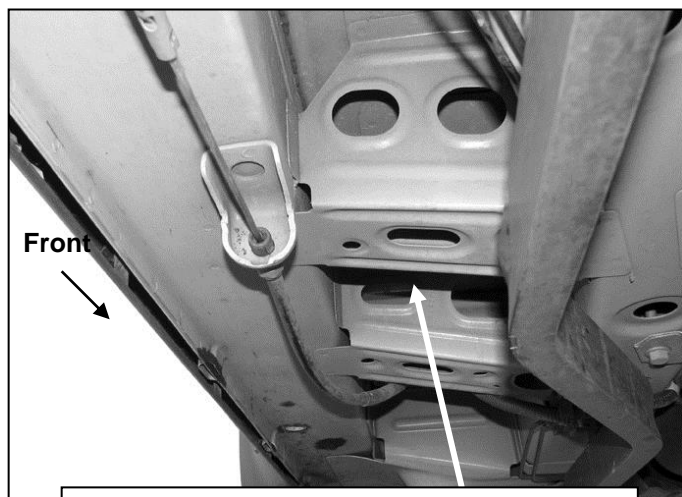

(Fig 5) Driver side center mounting location

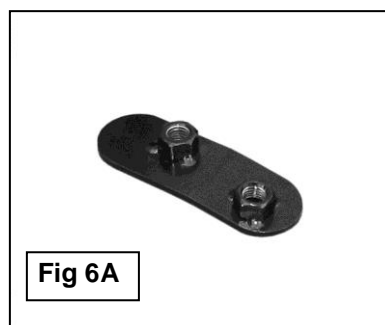

Fig 6A

Line up offset hole in Nut Plate with single small hole

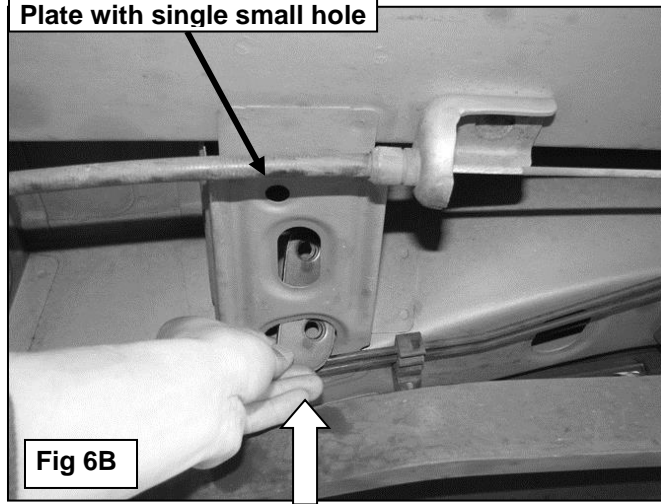
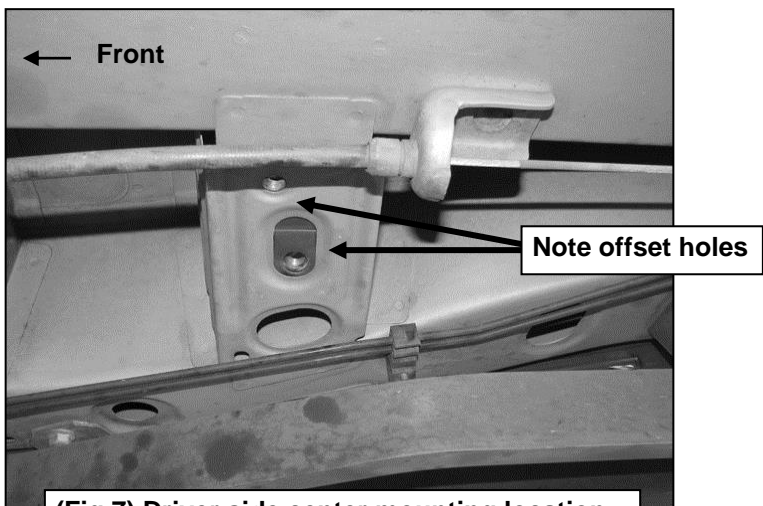

Fig 6B



(Fig 7) Driver side center mounting location

5. Select (1) Center Bracket. **NOTE:** There is no left or right to the center Bracket, they will fit either side. Line up the (2) holes in the Center Bracket with the Double Nut Plate. Bolt the Bracket to the Double Nut Plate with (2) 10mm Hex Bolts, (2) 10mm Lock Washers and (2) 10mm Flat Washers, (Figure 8). Leave hardware loose at this time.

(2) 10mm x 35mm Hex Bolts

(2) 10mm Lock Washers

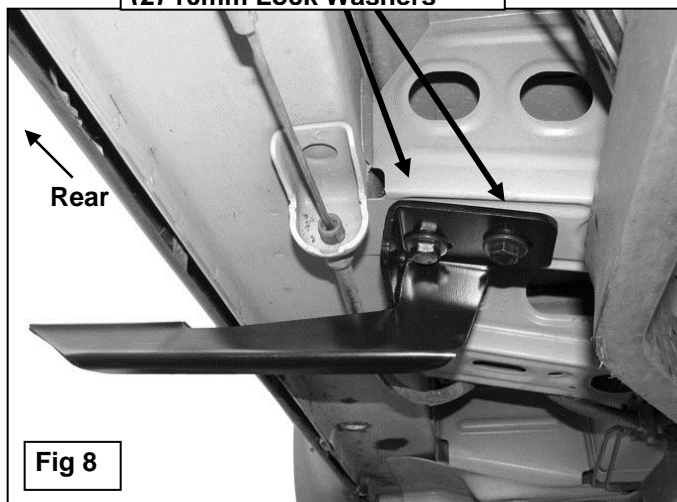

6. Continue along the floor panel toward the rear of the vehicle. Locate the round hole in the bottom of the floor panel as described in Step 1, (Figure 9). Repeat Steps 1 – 3 to install the remaining driver side Bracket in the rear location, (Fig. 10).

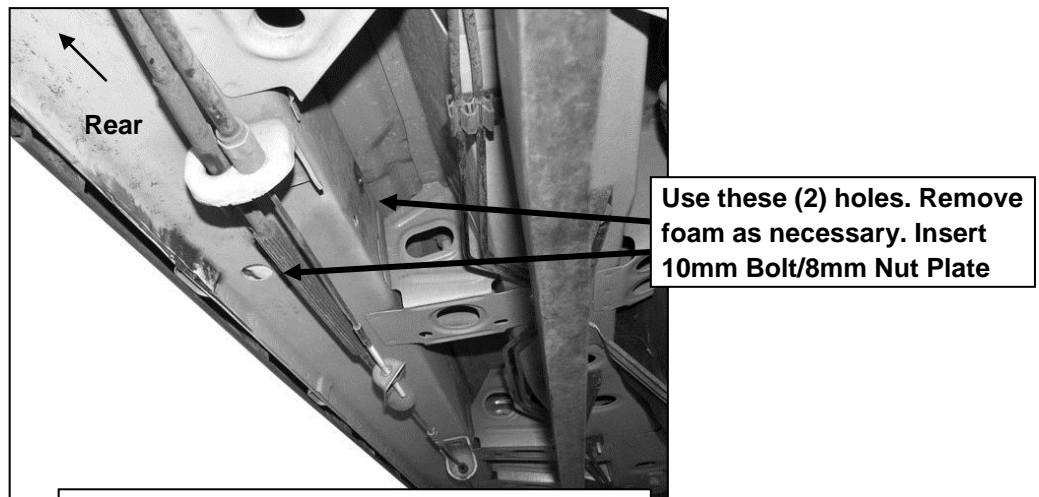

(Fig 9) Driver side rear mounting location

10mm Flat Washer
 10mm Lock Washer
 10mm Hex Nut

8mm x 30mm Hex Bolt
 8mm Lock Washer
 8mm Flat Washer

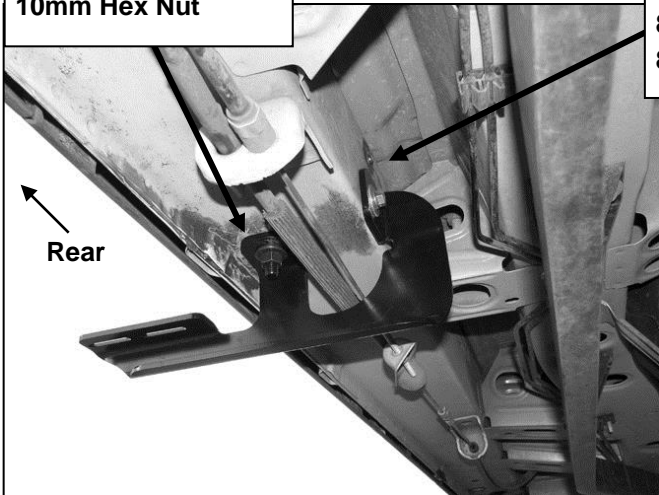

(Fig 10) Driver side rear Bracket pictured

- Carefully un-wrap the driver side Running Board. Insert (6) 6mm T-Bolts into the slots in the end of the channels, (3 T-Bolts per channel), on the bottom of the Running Board, (Fig. 11). Hold the Running Board up in approximate position and slide the T-Bolts down to line up with the (3) Mounting Brackets. Tilt the Board up at a slight angle and push back against the vehicle until the T-Bolts fit into the slots in the Brackets. Secure the Running Board to the Brackets with (6) 6mm Flat Washers, (6) 6mm Lock Washers and (6) 6mm Hex Nuts, (Fig. 12). Do not tighten hardware at this time. **NOTE:** The Center Bracket has a little adjustment in and out on the vehicle. Loosen the Bracket and slide the Center Bracket in or outward until it is in about the same position as the front and rear Brackets.

(2) 6mm Flat Washers
 (2) 6mm Lock Washers

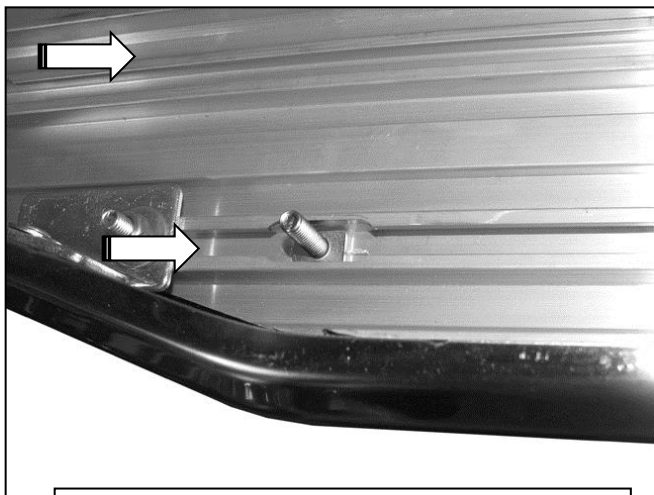

(Fig 11) Slide (3) T-Bolts into each channel

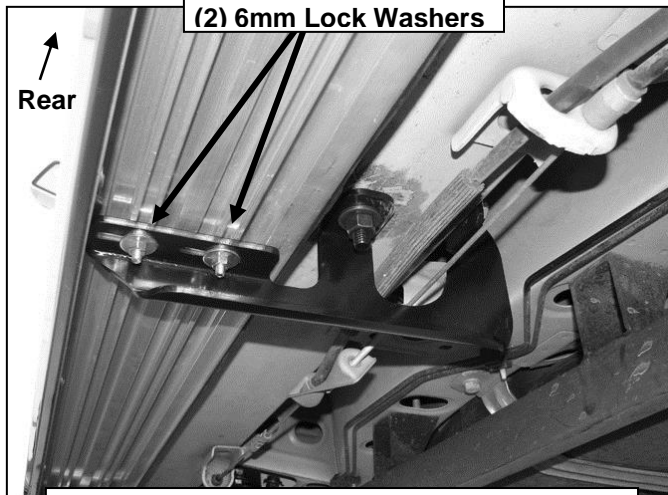

(Fig 12) Driver side rear Bracket installation

8. Level and adjust the Sidebar properly and tighten all hardware at this time.
9. Repeat **Steps 1 – 8** for passenger side Running Board installation. **IMPORTANT:** The Center Bracket and Double Nut Plate used are the same, driver side and passenger side.



PRODUCT CARE

- Periodically check the product to ensure all fasteners are tight and components are intact.
- Regular waxing is recommended to protect the finish of the product.
- **Use ONLY Non-Abrasive automotive wax.** Use of any soap, polish or wax that contains an abrasive is detrimental and can scratch the finish leading to corrosion.
- Aluminum polish may be used to polish small scratches and scuffs for **Stainless Steel finish.**
- Mild soap may be used to clean the product for both **Stainless Steel and Black finish.**

FAQ's**1. Hardware's are not of correct size.**

In GMC / Chevrolet truck model 2006 & up, customer needs to reuse the factory body bolts to install the bracket. If your vehicle is not GMC / Chevrolet 2006 & up, ensure that holes are not partially covered with any plastic grommet or rust? If it is, remove the plastic grommet & rust from the thread holes & re-try the installation.

2. Mounting Bracket are not getting Installed properly.

In some cases Illustration images shown in Installation manual may not be the exactly same as per actual vehicle images ,also if Driver / Passenger side mounting brackets are very identical in the design, suggest referring Parts Identification guide to avoid fitment issue.

3. Products are thumping / rattling after installation.

Ensure that all required mounting brackets / hardware's are installed & tighten correctly. Suggest using white lithium / regular grease between the metal to metal contact surfaces.

4. Side Bar is not aligning with vehicle / Step Pads are not aligning with vehicle doors.

Side bar may be interchanged or mounting brackets are not installed at the correct position in the vehicle. Refer Parts identification guide.

5. Missing / Excess Hardware.

Recheck hardware count as per the part list.

6. Product not installing properly.

Ensure make model year, cab length and bed size of your vehicle is listed in the application. All installation steps are followed correctly.

Check out these other TrailFX Products!!

www.TrailFX.com



SIDE BAR

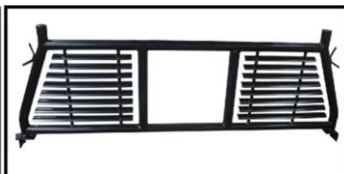

HEADACHE RACKS



HD GRILLE GUARDS



ROCKER GUARDS

Keystone Automotive Operations Inc. (KAO) warrants this product to be free of defects in material and workmanship at the time of purchase by the original retail consumer. KAO disclaims any other warranties, express or implied, including the warranty of fitness for a particular purpose or an intended use. If the product is found to be defective, KAO may replace or repair the product at our option, when the product is returned prepaid, with proof of purchase. Alteration to, improper installation, or misuse of this product voids the warranty. KAO's liability is limited to repair or replacement of products found to be defective, and specifically excludes liability for any incidental or consequential loss or damage.