

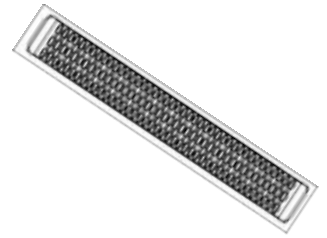

Aggressive Running Board

Part No. RBA003TI



Fits: **2007-Current**

**Chevrolet Silverado/GMC Sierra
1500/2500/3500 Crew Cab**



ASSISTANCE IS RECOMMENDED.



REMOVE CONTENTS FROM BOX. VERIFY ALL PARTS ARE PRESENT.



READ INSTRUCTIONS CAREFULLY BEFORE STARTING INSTALLATION.

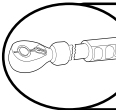

DO NOT OVER TORQUE. STANDARD OPERATING LOAD FOR TIGHTEN BODY MOUNT NUTS & BOLTS VARIES FROM 45 TO 65 FOOT POUND.



60-180 min



Cutting Required



Drilling Not Required



support@trailfx.com



1 866 638 4870



WARRANTY POLISHED STAINLESS STEEL – LIMITED LIFETIME
POWDER COATED BLACK – 3 YEARS

PARTS LIST:

Qty	Part Description	Qty	Part Description
2	Aggressive Running Boards	13	8-1.25mm x 25mm Hex Bolts
5	Mounting Brackets (use for left or right)	25	8mm x 24mm x 2mm Flat Washers
1	Passenger/right Front Upper Bracket (all incl. DEF)	25	8mm Lock Washers
1	Passenger/right Front Lower Bracket (all incl. DEF)	1	8mm Bolt Plate
11	8-1.25mm Clip-On Nuts	1	8mm Nylon Lock Nut (use w-bolt plate)
6	8mm Double Bolt Plates	12	8mm Hex Nuts

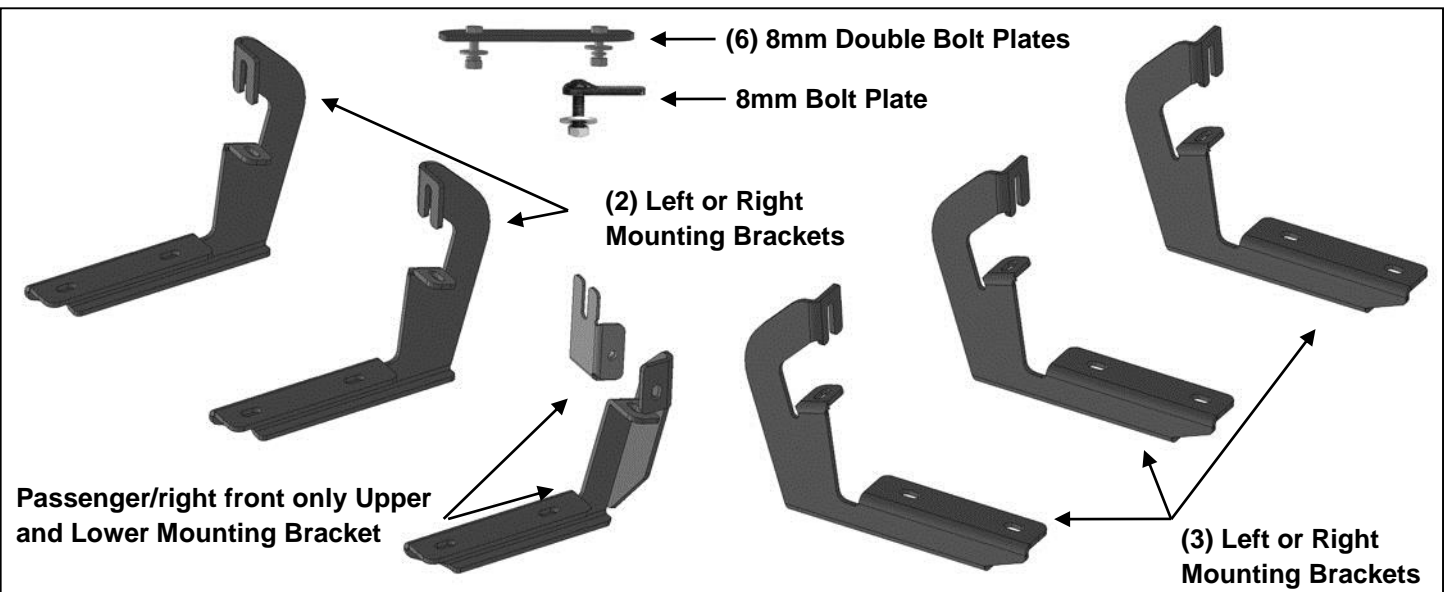

PROCEDURE:

ASSISTANCE IS RECOMMENDED. ON MODELS WITH DEF TANK, SELECT A FLAT, LEVEL AREA FOR INSTALLATION. MAY REQUIRE CUTTING.

1. Start the installation under the driver side of the vehicle. Locate the 5 tabs along the bottom edge of the body, (pinch weld). Mounting Brackets will bolt to the 1st, 2nd, (just in front of center of cab), and 5th mounting tabs, **(Figure 1)**. Directly above each tab is a top mounting location on the side of the body panel. Hold a Bracket up in place to help determine the mounting holes to use along the body.

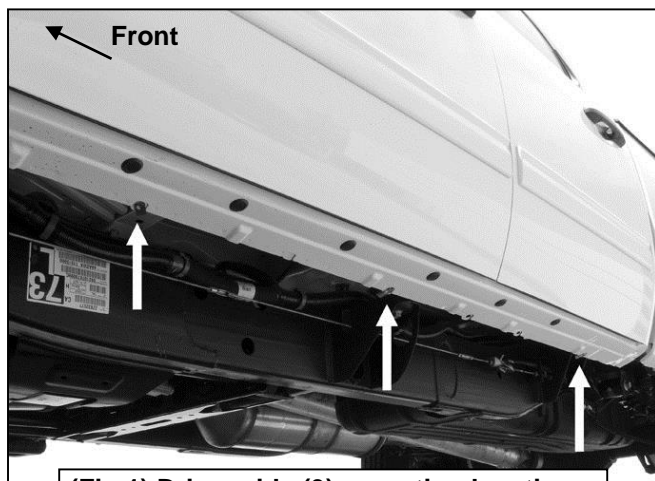

(Fig 1) Driver side (3) mounting locations

2. Determine the correct procedure for your model year and each Bracket location.

Bottom mounting location on the edge of the pinch weld.

Flat tab on pinch weld with factory installed weld nut:

Thread hex bolt into weld nut from the backside-down to clear paint from threads, **(Figure 2)**.

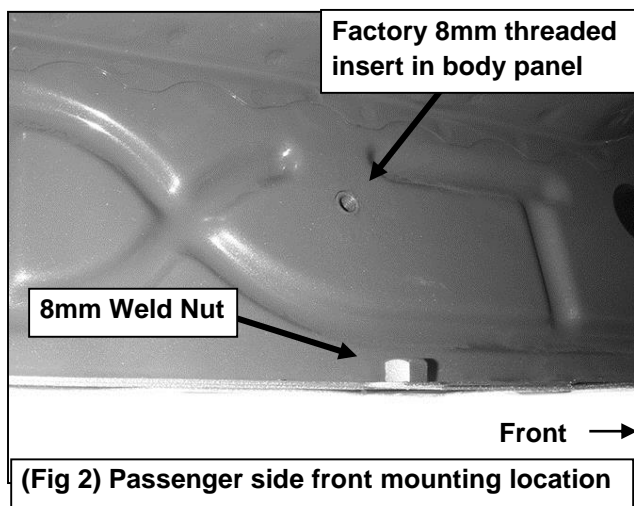

Flat tab on pinch weld with hole:

Select (1) 8mm Clip Nut. Slide the Clip Nut over the tab with the nut facing up behind the tab, **(Figures 3—5)**. Line up threaded nut with hole in the tab. Repeat for each mounting location.

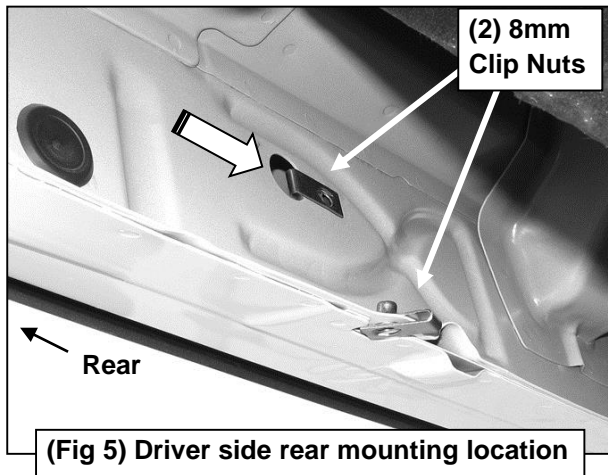
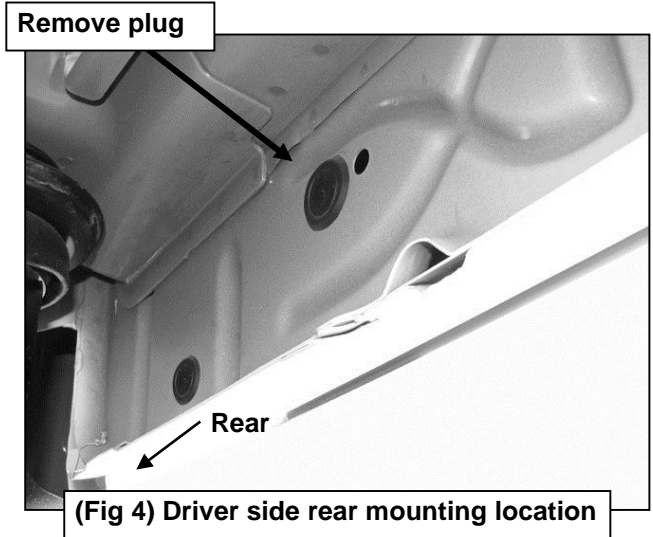
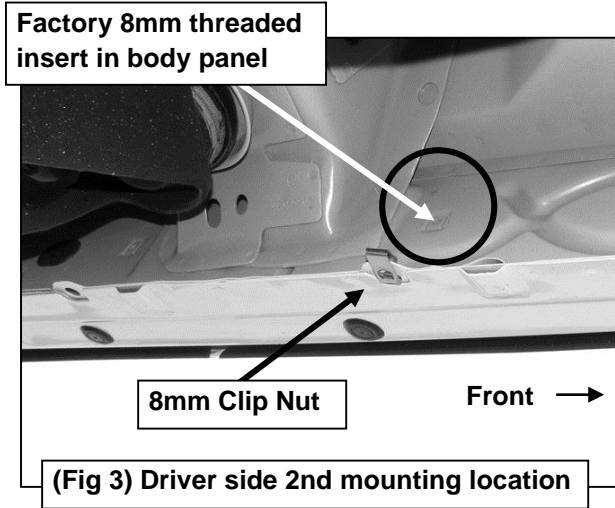

Locate top mounting location on the back side of the body panel.

Models with factory installed threaded insert in body panel:

Thread 8mm Hex Bolt into threaded insert to clear paint as required, (Figures 2 & 3).

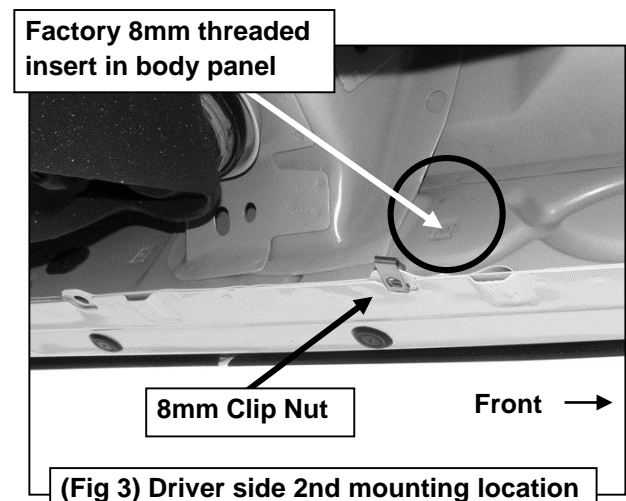
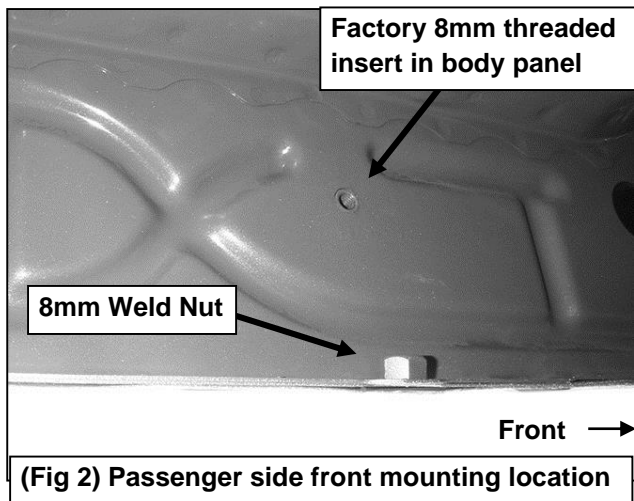

Large and small hole in side of body panel:

Remove the rubber plug from the larger hole, (Figure 4). Select (1) 8mm Clip Nut. Slide the Clip Nut into the larger hole. Line up the threaded nut with the smaller hole, (Figure 5).

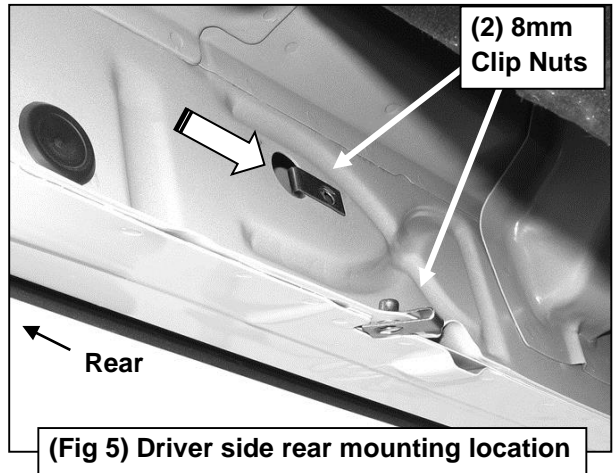
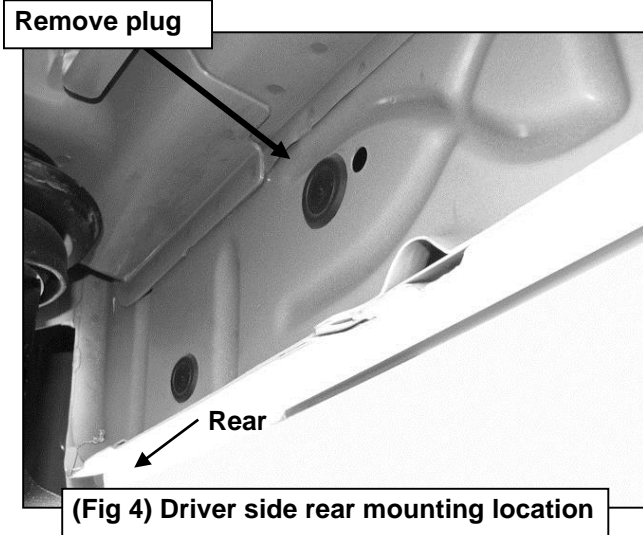

3. Select (1) Mounting Bracket. **NOTE:** (5) Brackets are universal and will fit all left side and only center and rear on right side. Attach the Mounting Bracket to the Clip Nuts and/or the factory threaded holes with (2) 8mm Hex Bolts, (2) 8mm Lock Washers and (2) 8mm Flat Washers, (Figures 6 & 7). Snug but do not fully tighten the hardware.

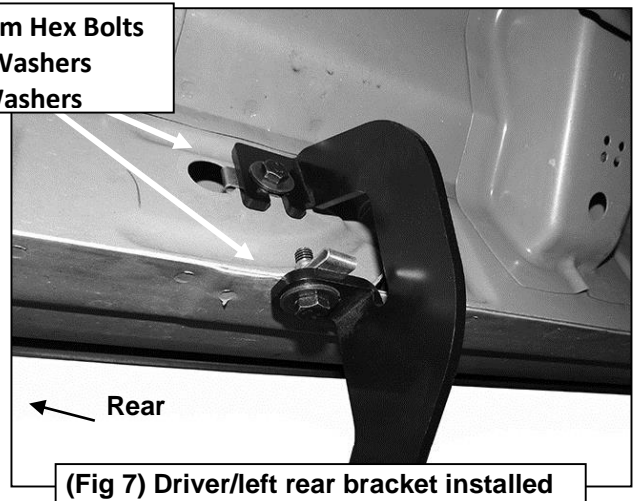
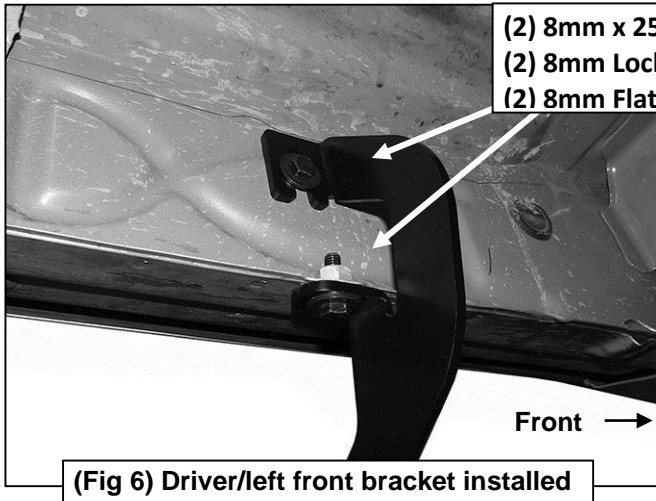

4. Repeat **Steps 1—3** to install the (2) remaining driver side Brackets, (Figures 6, 7, 10 & 11).

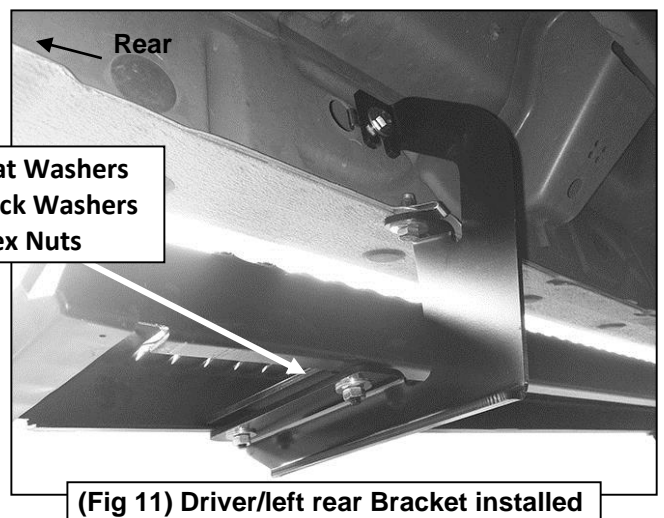
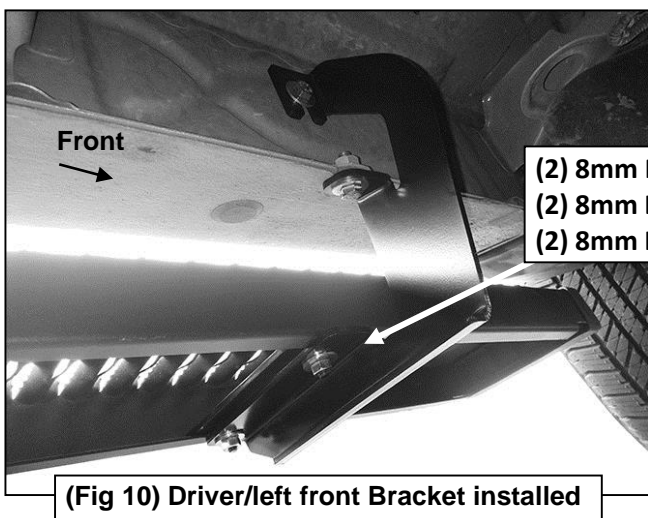

5. Carefully unwrap (1) Running Board. Place the Running Board on top of the (3) Brackets. Locate the channels in the bottom of the Running Board. Select (3) 8mm Double Bolt Plates, (Figure 8). Insert the Bolt Plates into the channels in the bottom of the Running Board closest to the Brackets, (Figure 9). Lift the Running Board up and guide the studs down through the Brackets.



(Fig 8) 8mm Double Bolt Plate

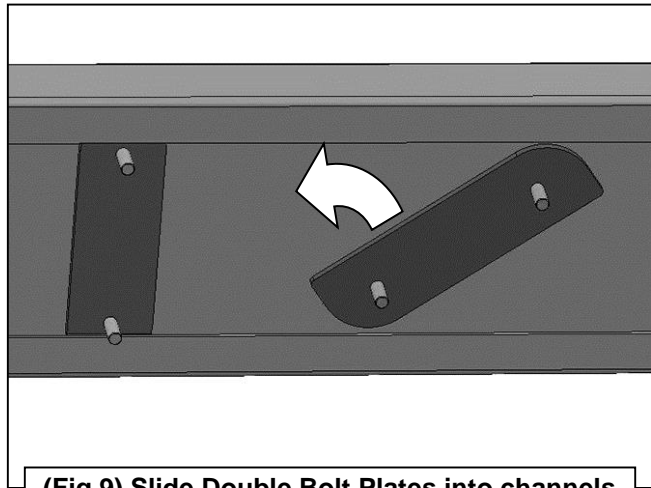

(Fig 9) Slide Double Bolt Plates into channels

6. Attach the Running Board to the Mounting Brackets with the included (6) 8mm Flat Washers, (6) 8mm Lock Washers and (6) 8mm Hex Nuts, (Figures 10 & 11). Do not tighten at this time.

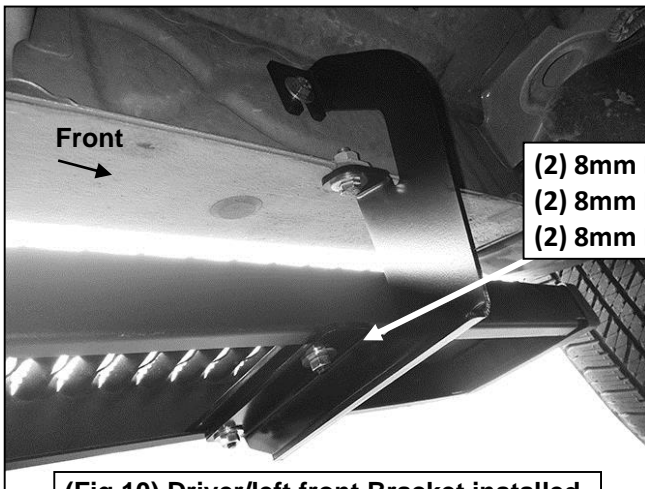

(Fig 10) Driver/left front Bracket installed

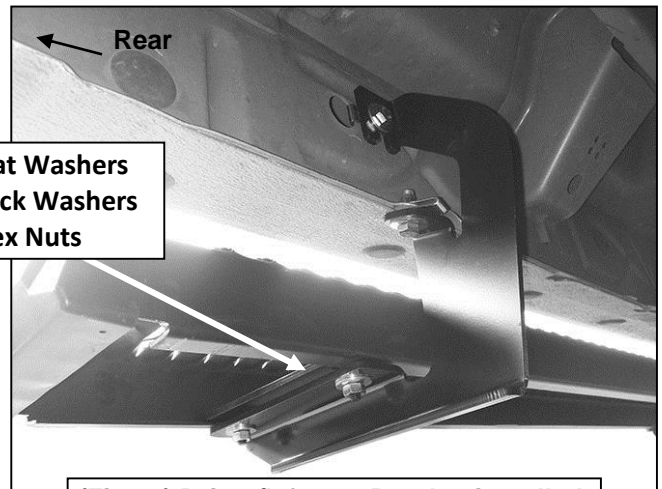

(Fig 11) Driver/left rear Bracket installed

(2) 8mm Flat Washers
(2) 8mm Lock Washers
(2) 8mm Hex Nuts

7. Level and adjust the Running Board as desired and tighten all hardware.
8. Move to the passenger side of the vehicle. On the passenger side, determine if the vehicle is equipped with a plastic diesel exhaust fluid (DEF) tank, (Figures 12 & 13).

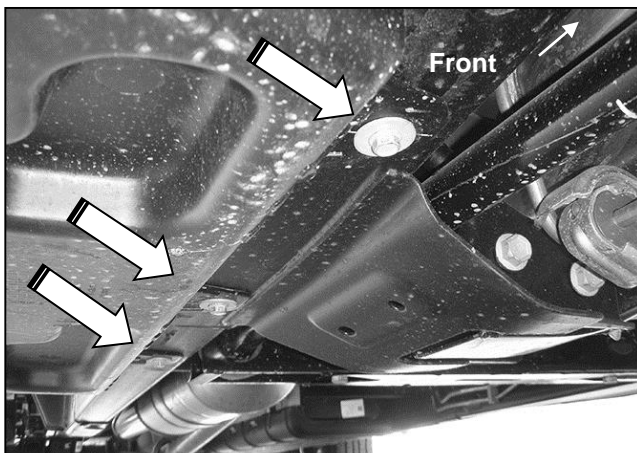

(Fig 12) 07-16 Passenger side front pictured with DEF tank cover. Remove (3) hex bolts to remove cover

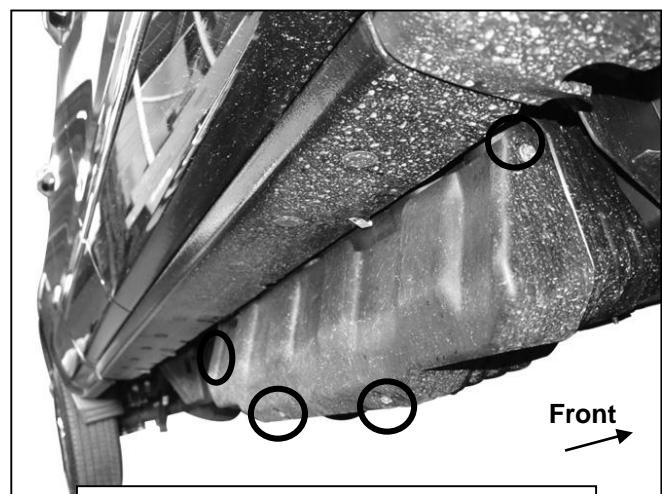

(Fig 13A) 2017 Passenger side pictured with DEF plastic tank cover. Remove (4) hex bolts to remove plastic cover

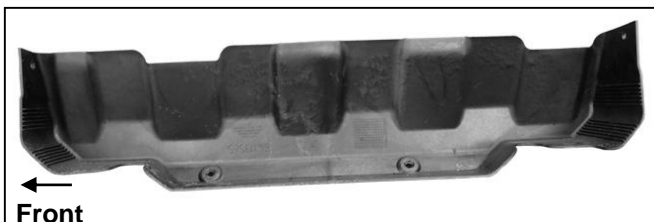

(Fig 13B) 2017 Passenger side DEF cover removed

Models without DEF tank, skip to Step 9.

Models with DEF tank: The tank sits close to the side of the body. With specialized tools, the passenger front upper and lower Bracket can be installed but room is limited. It may be easier to drop the tank down to access the inner side of the body panel for upper bracket installation. Tank will not need to be removed, only dropped down for access to mounting location. **IMPORTANT:** If tank is full, it will be very heavy and assistance is highly recommended to avoid injury or damage to the vehicle or the tank. It is recommended that installation is performed when the DEF tank is low on fluid before dropping the tank.

- a. On models with plastic lower tray under the tank, remove the (3) hex bolts attaching the tray to the frame, (**Figure 12**), and remove the tray. **2017 2500/3500 models:** Remove the (4) hex bolts attaching plastic cover to DEF tank, (**Figure 13A**) and remove plastic cover, (**Figure 13B**).

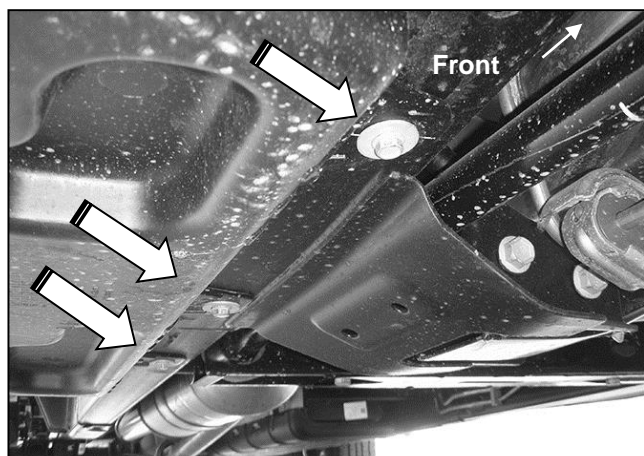

(Fig 12) 07-16 Passenger side front pictured with DEF tank cover. Remove (3) hex bolts to remove cover



(Fig 13A) 2017 Passenger side pictured with DEF plastic tank cover. Remove (4) hex bolts to remove plastic cover

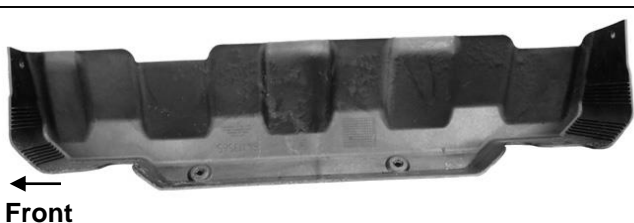

(Fig 13B) 2017 Passenger side DEF cover removed

- b. Release the tank filler hose. Release the plug for the sending unit on the top of the tank.
- c. Support the tank with a floor jack. Place a smooth flat surface, (wooden block for example), between the floor jack and the tank to avoid damaging the plastic tank. Do not push up on the tank; only support the weight of the tank with the jack.
- d. Remove the (2) bolts securing the tank straps to the vehicle, (**Figure 14**). Tilt the straps to release from the brackets. Slowly lower the tank until the top of the tank is almost visible. Use blocks or stands to support the tank while installing the front Upper and Lower Brackets.

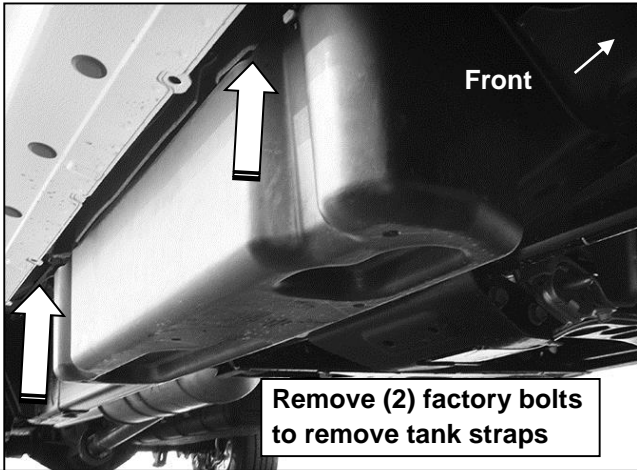

Remove (2) factory bolts to remove tank straps

(Fig 14) 07-16 Passenger side DEF tank and cover

e. Proceed to Step 9.

9. Locate the first tab on the edge of the pinch weld, (Figures 2—5, 16 & 18). Select the Upper Bracket, (Figure 15). Repeat Steps 2 & 3 to attach the passenger front Upper Bracket to the side of the body panel, (Figure 16). Do not tighten hardware at this time.

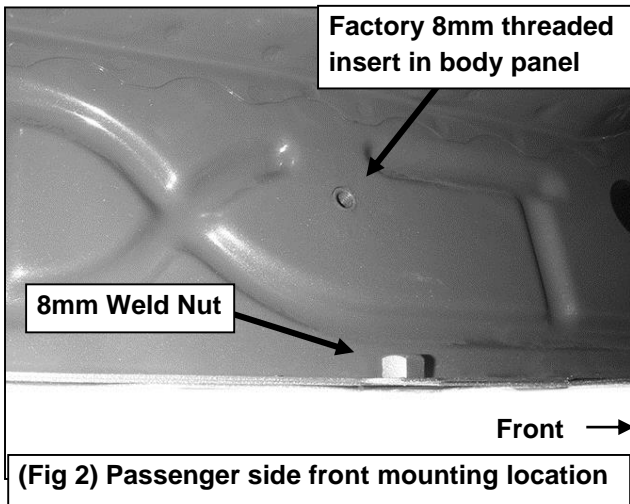

(Fig 2) Passenger side front mounting location

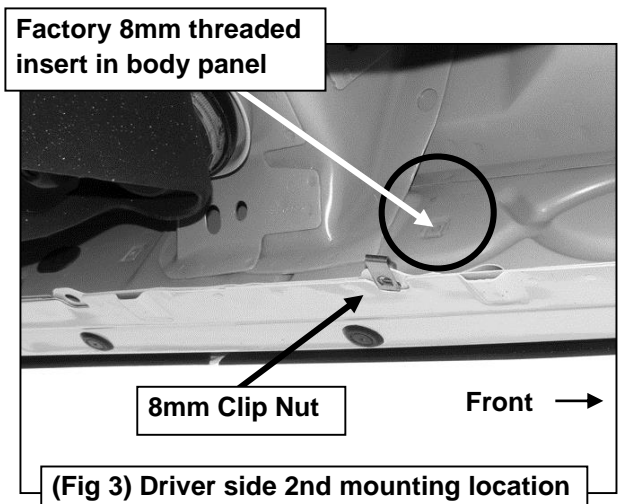

(Fig 3) Driver side 2nd mounting location

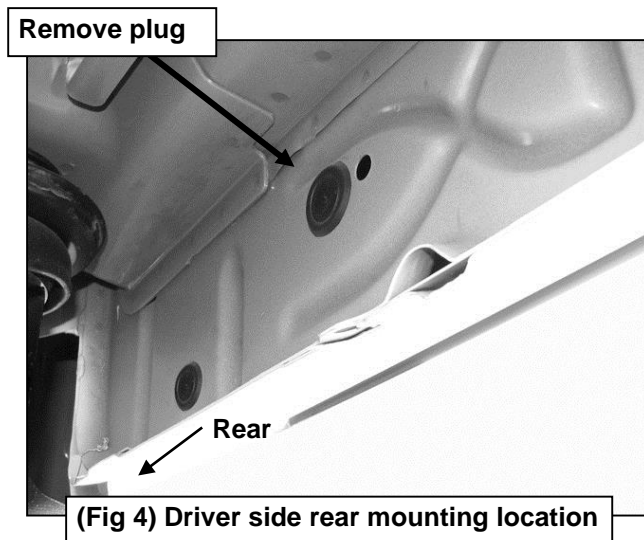

(Fig 4) Driver side rear mounting location

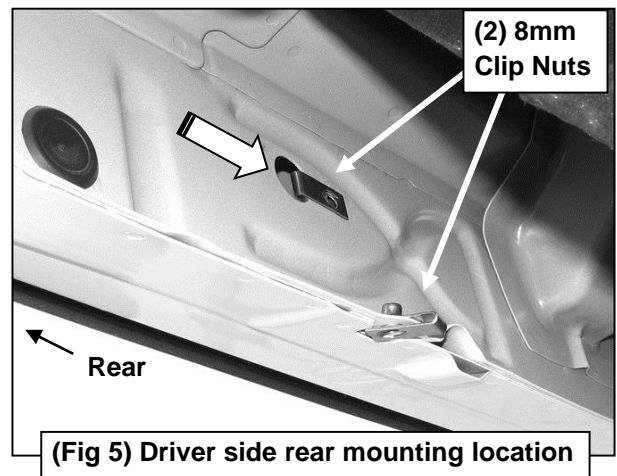

(Fig 5) Driver side rear mounting location

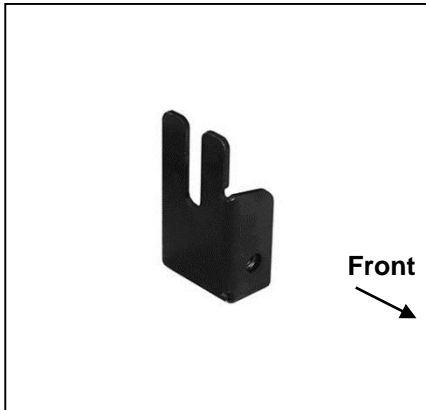

(Fig 15) Passenger/right Front Upper Bracket (all models)



(Fig 16) Slide Upper Bracket over weld nut if equipped-also see Figure 2

On models with flat tab (see Fig 3 & 4), insert 8mm Bolt Plate (Fig 17) down through Upper Bracket and mounting tab

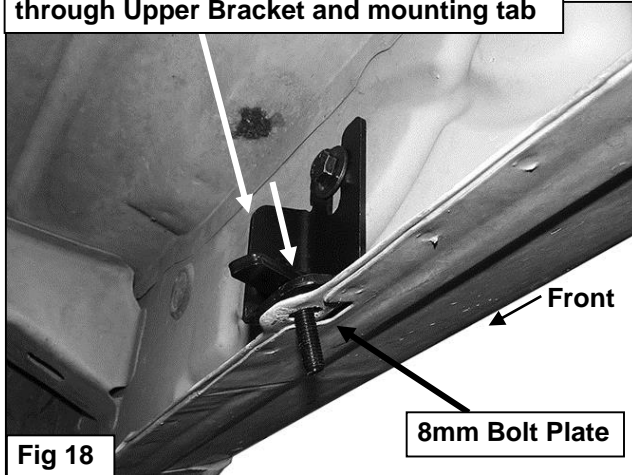

Fig 18

10. Line up the hole in the bottom of the Upper Bracket with the hole in the tab on the pinch weld.

- a. **Models with a weld-nut:** Slide the Bracket over the weld-nut, (Figure 16). Attach the Lower Bracket to the bottom of the body and weld-nut with (1) 8mm x 25mm Hex Bolt, (1) 8mm Lock Washer and (1) 8mm Flat Washer, (Figure 24). Leave loose at this time.



(Fig 16) Slide Upper Bracket over weld nut if equipped-also see Figure 2

<p>All models use: 8mm x 25mm Hex Bolt 8mm Lock Washer 8mm Flat Washer</p>	<p>Models with weld nut on tab (see Fig. 14) use: 8mm x 25mm Hex Bolt 8mm Lock Washer 8mm Flat Washer</p>
---	--



Fig 24

- b. **Models with flat tab and hole:** Insert the 8mm Bolt Plate down through the hole in the Upper Bracket and mounting tab, (**Figures 17 & 18**). Attach the Lower Bracket to the bottom of the body and Bolt Plate with (1) 8mm Flat Washer and (1) 8mm Nylon Lock Nut, (**Figure 23**). Leave loose at this time.



(Fig 17) 8mm x 35mm Bolt Plate

On models with flat tab (see Fig 3 & 4), insert 8mm Bolt Plate (Fig 17) down through Upper Bracket and mounting tab

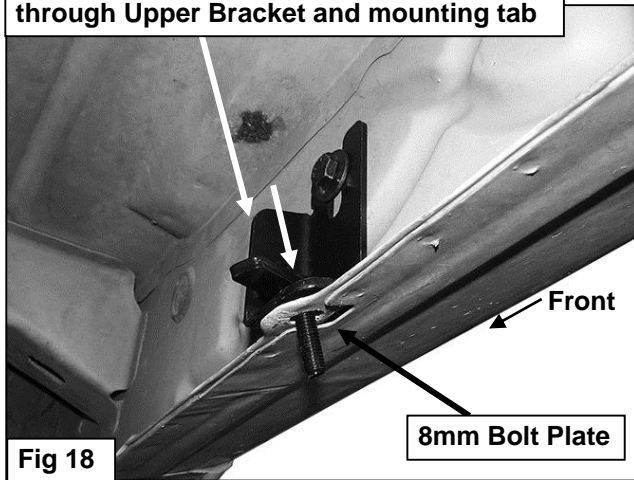
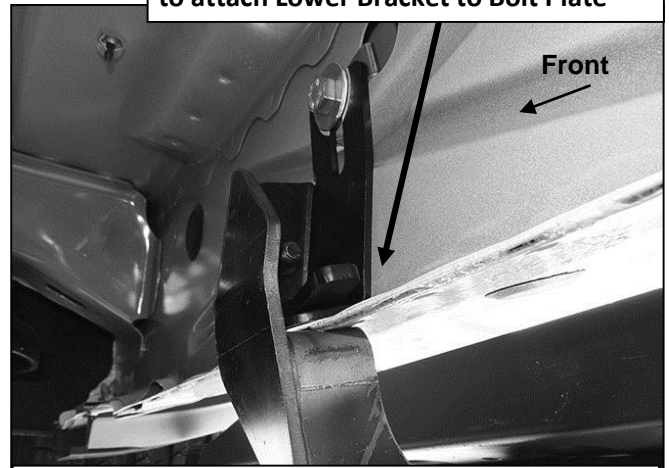

Fig 18

On models with flat tab and 8mm Bolt Plate (see Fig. 16) use:
8mm Flat Washer
8mm Nylon Lock Nut
to attach Lower Bracket to Bolt Plate



(Fig 23) Passenger/right front Bracket installation

11. Line up the side tab on the Lower Bracket with the threaded hole in the side of the Upper Bracket. Attach the Lower Bracket to the Upper Bracket with (1) 8mm x 25mm Hex Bolt, (1) 8mm Lock Washer and (1) 8mm Flat Washer, (**Figure 22**). Leave loose at this time.

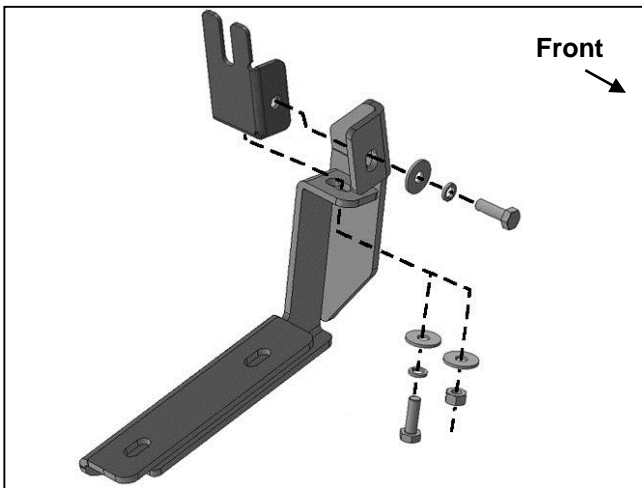

(Fig 22) Passenger/right Front Upper and Lower Brackets

12. Repeat **Steps 1—3** for the (2) remaining passenger side Bracket installations. **NOTE:** Cradles on Brackets installed on passenger side will face forward.
- a. **2017 2500/3500 DEF tank models:** Locate the 2nd tab bracket location along the bottom edge of the body, (pinch weld), (**Figure 19**). Hold the DEF cover in place and mark the 2nd Bracket location onto the cover, (**Figure 20**). Use a sharp knife or hacksaw blade to carefully cut a slot in the plastic cover to clear the 2nd Bracket, (**Figure 21**). Remove as little plastic as possible.

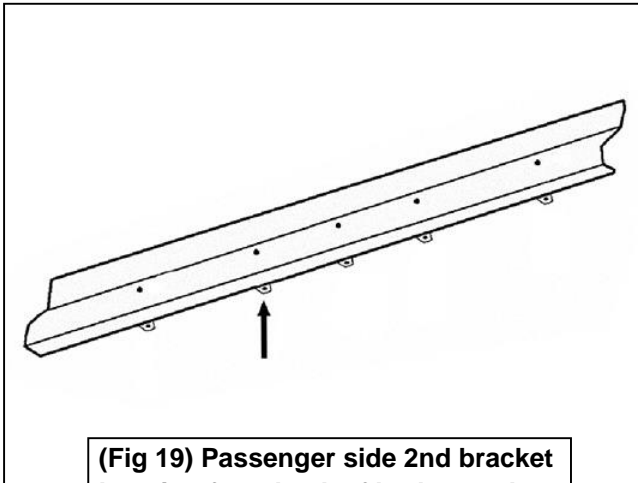

(Fig 19) Passenger side 2nd bracket location from back of body panel



mark pictured is approximately 70mm x 10mm

(Fig 20) 2017 Passenger side DEF cover marked for trimming

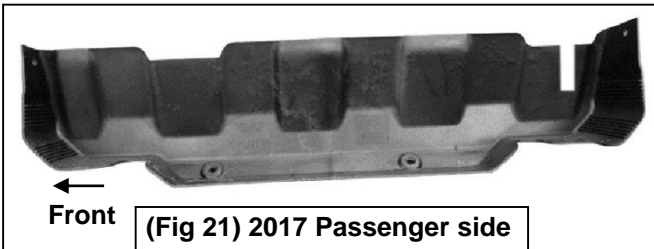

(Fig 21) 2017 Passenger side DEF cut for example only

- 13. Repeat **Steps 5 & 6** to install the passenger side Running Board.
- 14. Once the Running Board has been installed and all hardware fully tightened, reinstall the DEF tank and cover, if equipped, as described in **Steps 8 & 12**.
- 15. Do periodic inspections to the installation to make sure that all hardware is secure and tight.



Complete Installation

PARTS IDENTIFICATION GUIDE

Driver Side tube packed using "Green" color foam sheet. Passenger Side tube packed using "White" color foam sheet

No.	Parts Identification
1	Passenger / Right 'Rear' Bracket marked "PR"
2	Driver / Left 'Rear' Bracket marked "DR"
3	Passenger / Right 'Center' Bracket marked "PC"
4	Driver / Left 'Center' Bracket marked "DC"
5	Passenger / Right 'Front' Bracket marked "PF"
6	Driver / Left 'Front' Bracket marked "DF"

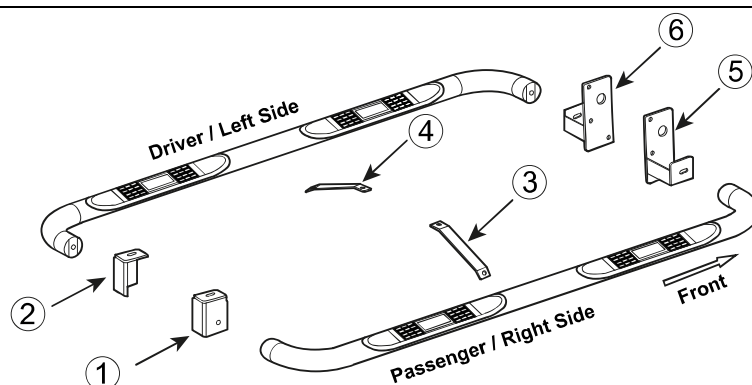
**Note:**

- This guide is to identify the parts and not a reference for part count.
- For part count, refer Parts List.
- Product / Bracket image is representative and actual design may vary.

PRODUCT CARE

- Periodically check the product to ensure all fasteners are tight and components are intact.
- Regular waxing is recommended to protect the finish of the product.
- **Use ONLY Non-Abrasive automotive wax.** Use of any soap, polish or wax that contains an abrasive is detrimental and can scratch the finish leading to corrosion.
- Aluminum polish may be used to polish small scratches and scuffs for **Stainless Steel finish.**
- Mild soap may be used to clean the product for both **Stainless Steel and Black finish.**

FAQ's**1. Hardware's are not of correct size.**

In GMC / Chevrolet truck model 2006 & up, customer needs to reuse the factory body bolts to install the bracket. If your vehicle is not GMC / Chevrolet 2006 & up, ensure that holes are not partially covered with any plastic grommet or rust? If it is, remove the plastic grommet & rust from the thread holes & re-try the installation.

2. Mounting Bracket are not getting Installed properly.

In some cases Illustration images shown in Installation manual may not be the exactly same as per actual vehicle images ,also if Driver / Passenger side mounting brackets are very identical in the design, suggest referring Parts Identification guide to avoid fitment issue.

3. Products are thumping / rattling after installation.

Ensure that all required mounting brackets / hardware's are installed & tighten correctly. Suggest using white lithium / regular grease between the metal to metal contact surfaces.

4. Side Bar is not aligning with vehicle / Step Pads are not aligning with vehicle doors.

Side bar may be interchanged or mounting brackets are not installed at the correct position in the vehicle. Refer Parts identification guide.

5. Missing / Excess Hardware.

Recheck hardware count as per the part list.

6. Product not installing properly.

Ensure make model year, cab length and bed size of your vehicle is listed in the application. All installation steps are followed correctly.

Check out these other TrailFX Products!!

www.TrailFX.com

**BULL BAR****GRILLE GUARDS****BED RAILS****RUNNING BOARDS**

Keystone Automotive Operations Inc. (KAO) warrants this product to be free of defects in material and workmanship at the time of purchase by the original retail consumer. KAO disclaims any other warranties, express or implied, including the warranty of fitness for a particular purpose or an intended use. If the product is found to be defective, KAO may replace or repair the product at our option, when the product is returned prepaid, with proof of purchase. Alteration to, improper installation, or misuse of this product voids the warranty. KAO's liability is limited to repair or replacement of products found to be defective, and specifically excludes liability for any incidental or consequential loss or damage.