

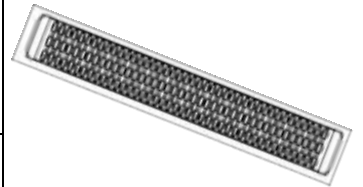

# Aggressive Running Board

Part No. RBA006TI



Fits: **2009-Current**  
**2010-Current**

**Dodge Ram 1500 Crew Cab**  
**Dodge Ram 2500/3500 Crew Cab**



EXCL. CHASSIS CAB DIESEL MODELS



REMOVE CONTENTS FROM BOX. VERIFY ALL PARTS ARE PRESENT.



READ INSTRUCTIONS CAREFULLY BEFORE STARTING INSTALLATION.

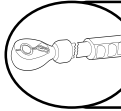

DO NOT OVER TORQUE. STANDARD OPERATING LOAD FOR TIGHTEN BODY MOUNT NUTS & BOLTS VARIES FROM 45 TO 65 FOOT POUND.



60-180 min



Cutting Not Required



Drilling Required



support@trailfx.com



1 866 638 4870



POLISHED STAINLESS STEEL – LIMITED LIFETIME  
POWDER COATED BLACK – 3 YEARS

### PARTS LIST:

Qty	Part Description	Qty	Part Description
2	Running Boards	36	8mm x 24mm x 2mm Flat Washers
3	Driver/left Front, Center and Passenger Rear Mounting Brackets	24	8mm Lock Washers
3	Passenger/right Front, Center and Driver Rear Mounting Brackets	18	8mm Hex Nuts
3	Support Brackets (DS Front/Center & PS Rear)	6	8mm Nylon Lock Nuts
3	Support Brackets (PS Front/Center & DS Rear)	6	8mm Double Bolt Plates
6	8mm Nut/Bolt Plates	12	6mm x 25mm Hex Bolts
6	8mm Plastic Retainers	24	6mm x 22mm x 2mm Flat Washers
18	8mm-1.25 x 30 Hex Bolts	12	6mm Nylon Lock Nuts

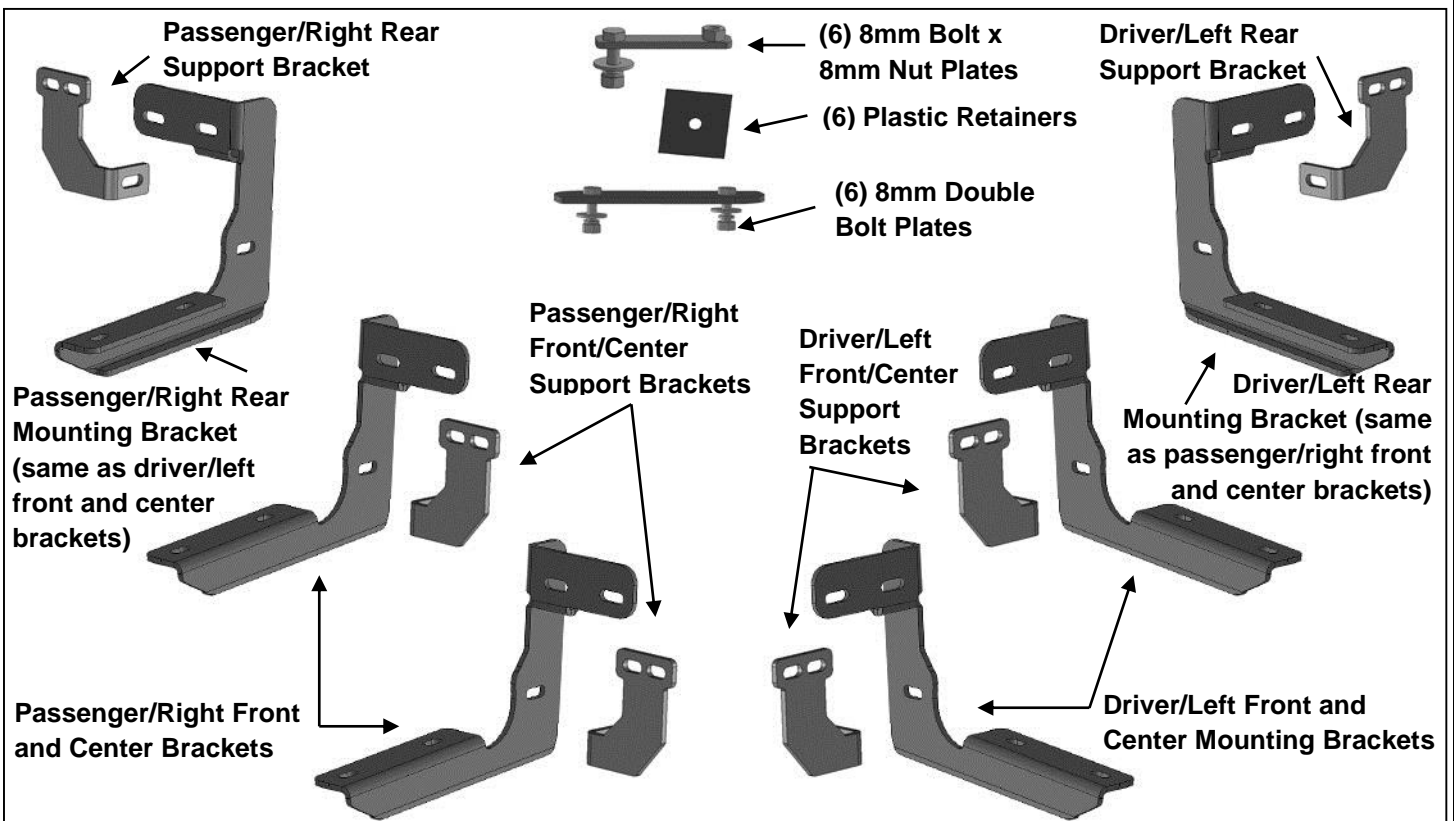

**INSTALLATION PROCEDURE:**

1. REMOVE CONTENTS FROM BOX. VERIFY ALL PARTS ARE PRESENT. READ INSTRUCTIONS CAREFULLY BEFORE STARTING INSTALLATION. DRILLING MAY BE REQUIRED.
2. Starting at the driver side-front of the vehicle, remove the sealing tape covering the factory holes in the side of the inner panel, (Figure 1).

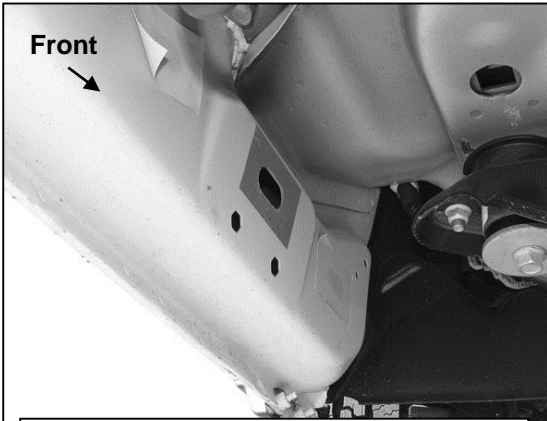

**(Fig 1) 2009-mid 2015 Driver/Left front mounting location (No factory holes in pinch weld 2009-2011 models)**

3. Determine the correct procedure to attach the driver side front Bracket for your model/year:

**Models without factory threaded inserts in body panel:**

- a. Partially thread an 8mm Hex Bolt into the threaded end of an 8mm Bolt and Nut Plate, (Figure 2). Thread the Hex Bolt in until it is flush with the welded nut, (Figure 3). Use the Hex Bolt as a handle and insert the Bolt and Nut Plate into the oval hole, (Figure 4). Feed the threaded bolt on the Bolt Plate out through one of the hex shaped factory holes. Thread (1) 8mm Plastic Retainer onto the threaded end and down tight against the body panel, (Figure 5). **NOTE:** The Retainer is designed to keep the Bolt/Nut Plate from falling into the body panel and to aid in Bracket installation.

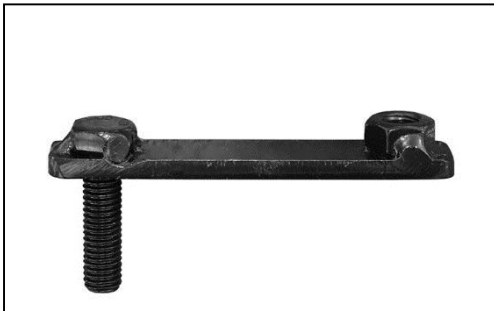

**(Fig 2) 8mm Bolt-8mm Nut Plate, NOTE: 8mm Bolt-Nut Plate is not required on models with threaded inserts**

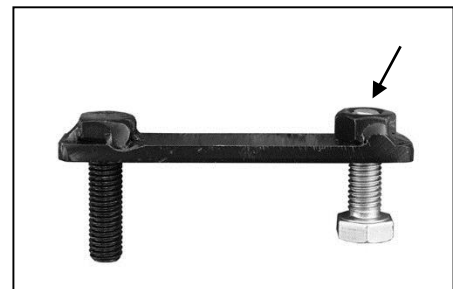

**(Fig 3) Thread (1) 8mm Hex Bolt into the nut on the plate. Stop when bolt reaches end of nut as pictured**

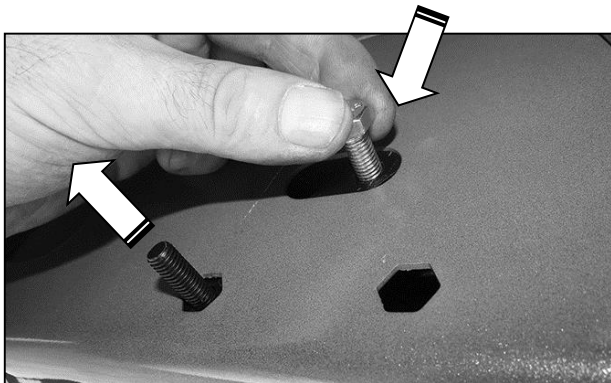

**(Fig 4) Use the loose Hex Bolt as a handle. Insert the Bolt Plate into the oval hole and feed the threaded end out either factory hex shaped hole. IMPORTANT: Do not let go of the hex bolt until after Plastic Retainer has been threaded onto bolt (Fig 5)**

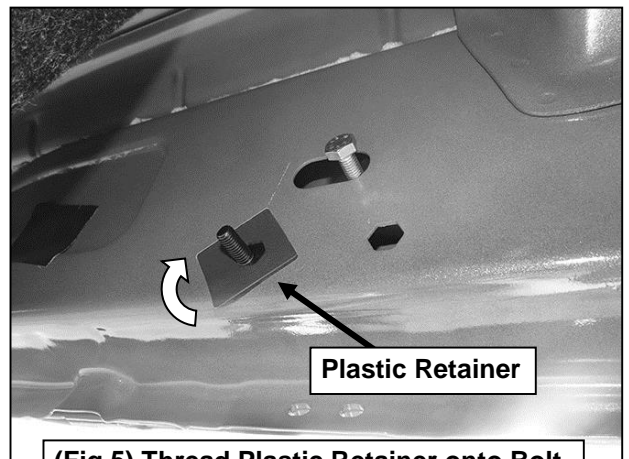

**(Fig 5) Thread Plastic Retainer onto Bolt Plate to hold Bolt Plate in position.**

- b. Select the driver side front Mounting Bracket, **(Figure 6)**. Attach the Bracket to the threaded end of the Bolt Plate with (1) 8mm Flat Washer, (1) 8mm Lock Washer and (1) 8mm Hex Nut, **(Figure 7A)**. Do not tighten at this time.

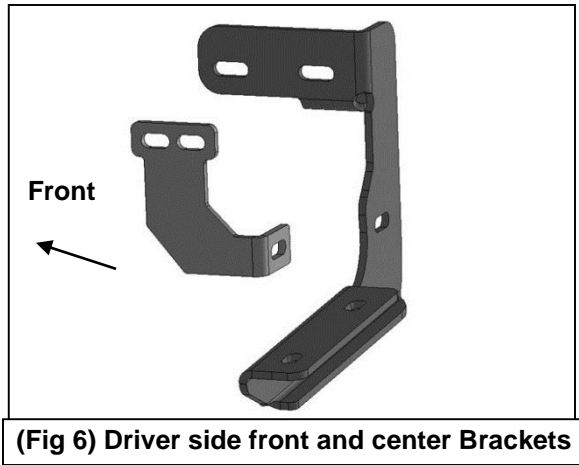

**(Fig 6) Driver side front and center Brackets**

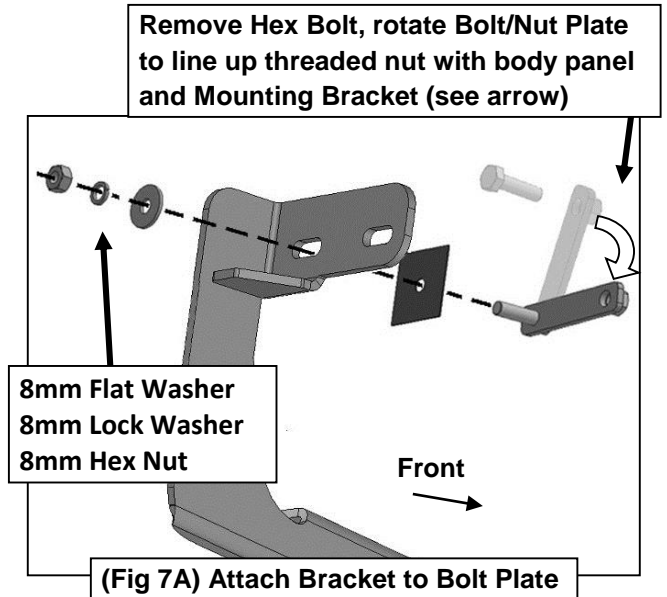

**(Fig 7A) Attach Bracket to Bolt Plate**

- c. Remove the 8mm Hex Bolt from the nut on the Bolt Plate from **Step 3a**. Rotate the Bolt on the Bolt Plate until the threaded nut lines up with the remaining hole in the Mounting Bracket and body panel, **(Figure 7B)**. Attach the Bracket to the threaded Nut Plate with (1) 8mm x 30mm Hex Bolt, (1) 8mm Lock Washer and (1) 8mm Flat Washer. Do not tighten hardware at this time.

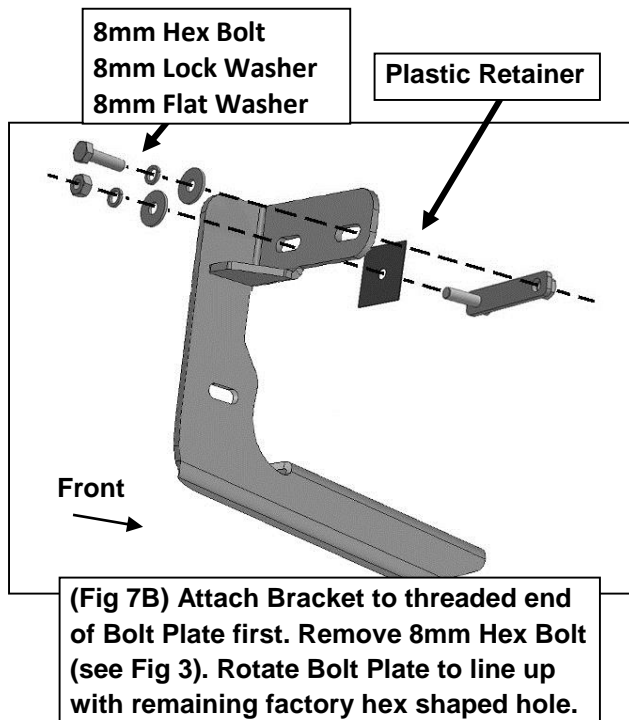

**(Fig 7B) Attach Bracket to threaded end of Bolt Plate first. Remove 8mm Hex Bolt (see Fig 3). Rotate Bolt Plate to line up with remaining factory hex shaped hole.**

**Models with factory threaded inserts:**

- a. Attach the driver side Front Bracket to the threaded inserts with (2) 8mm x 30mm Hex Bolts, (2) 8mm Lock Washers and (2) 8mm Flat Washer, **(Figures 8 & 9)**. Leave hardware loose.

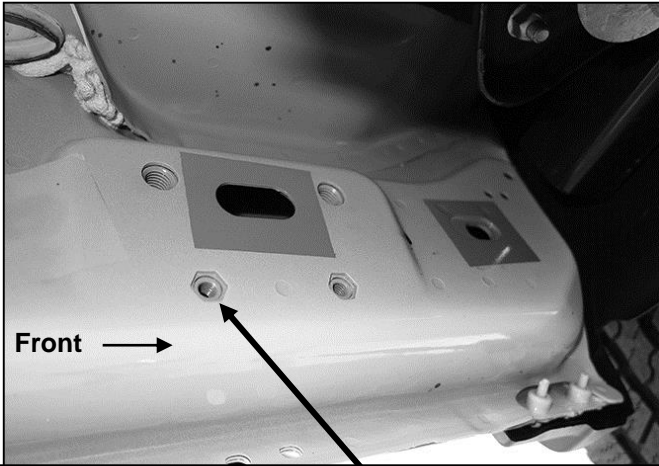

(Fig 8) Driver side front mid 2015-on, an example of models with factory installed threaded inserts

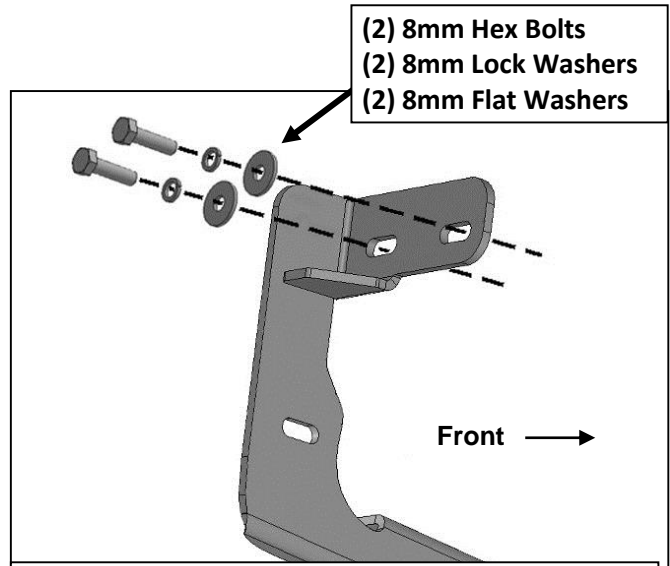

(Fig 9) Driver side front models with factory installed threaded inserts. Bolt Plate not required

4. Next, select the driver side front Support Bracket. Attach the Bracket to the front facing side of the front Bracket with (1) 8mm x 30mm Hex Bolt, (2) 8mm Flat Washers and (1) 8mm Nylon Lock Nut, (Figure 10). Rotate the Support Bracket to the back of the pinch weld. Line up the slots in the top of the Support Bracket with the (2) factory holes in the pinch weld. Attach the Bracket to the back of the pinch weld with (2) 6mm x 25mm Hex Bolts, (4) 6mm Flat Washers and (2) 6mm Nylon Lock Nuts, (Figures 11 & 12). Do not fully tighten hardware at this time. **IMPORTANT: 2009-10** models are not equipped with factory holes and will require drilling through the pinch weld to attach the Support Bracket. Do not drill through pinch weld at this time, (see Step 9).

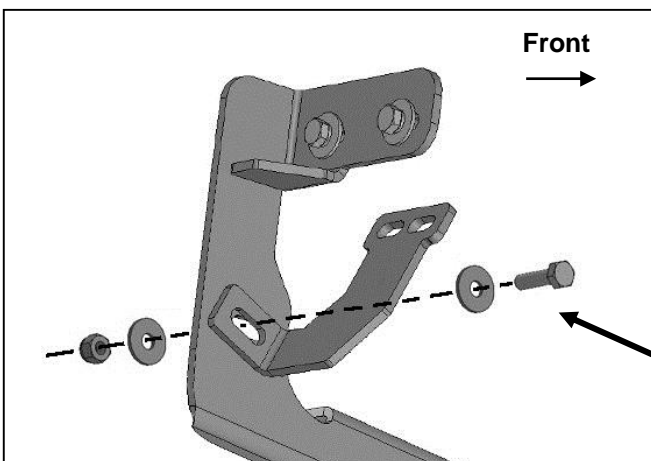

(Fig 10) Attach Driver/Left front Support Bracket to front facing side of Mounting Bracket

8mm Hex Bolt  
(2) 8mm Flat Washers  
8mm Nylon Lock Nut

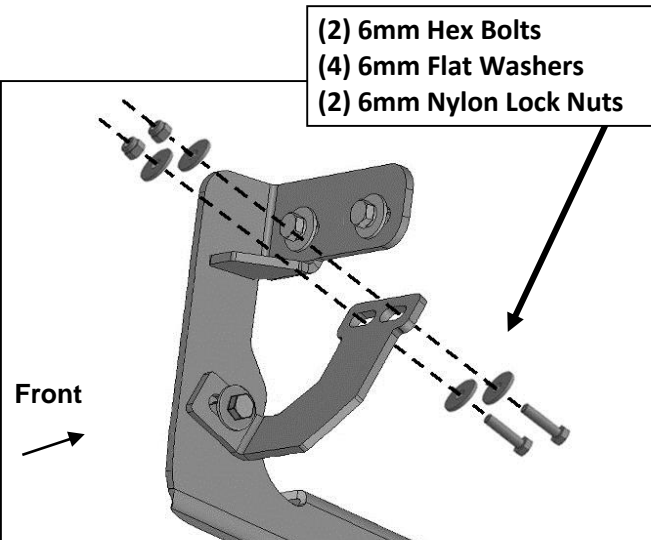

(Fig 11) Attach Support Bracket to back of pinch weld (models with factory holes in pinch weld only)

(2) 6mm Hex Bolts  
(4) 6mm Flat Washers  
(2) 6mm Nylon Lock Nuts

8mm Hex Bolt  
(2) 8mm Flat Washers  
8mm Nylon Lock Nut

(2) 6mm Hex Bolts  
(4) 6mm Flat Washers  
(2) 6mm Nylon Lock Nuts

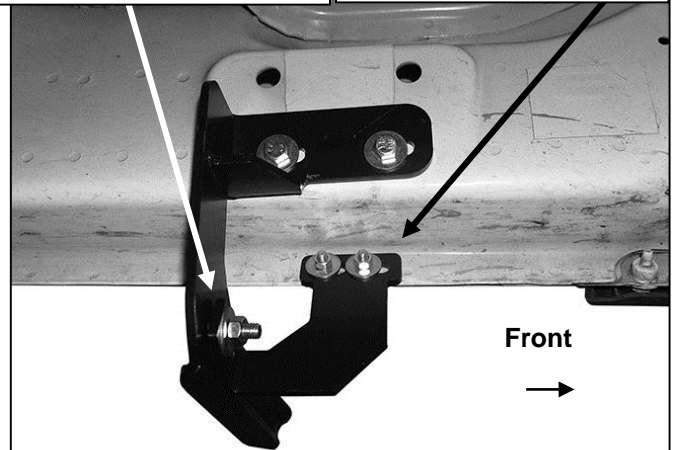

(Fig 12) Driver side front Bracket assembly

5. Move along the side of the body panel to the center mounting location, **(Figure 13)**. Repeat the appropriate **Step 3** to install the driver side center Bracket, **(Figure 14)**. Select (1) driver side front/center Support Bracket. Repeat **Step 4** to attach the Support Bracket to the front of the center bracket and factory holes (if equipped) in the pinch weld.

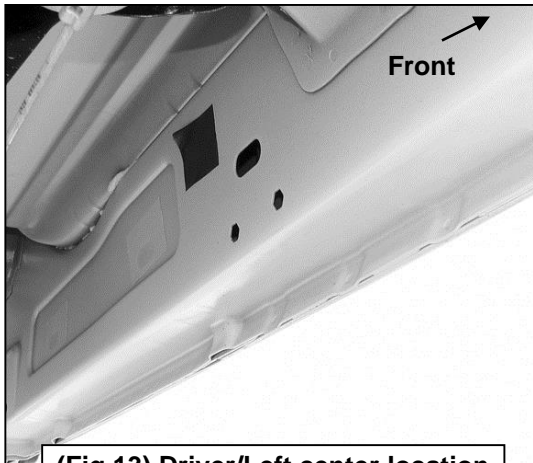

**(Fig 13) Driver/Left center location**

**8mm Hex Bolt  
(2) 8mm Flat Washers  
8mm Nylon Lock Nut**

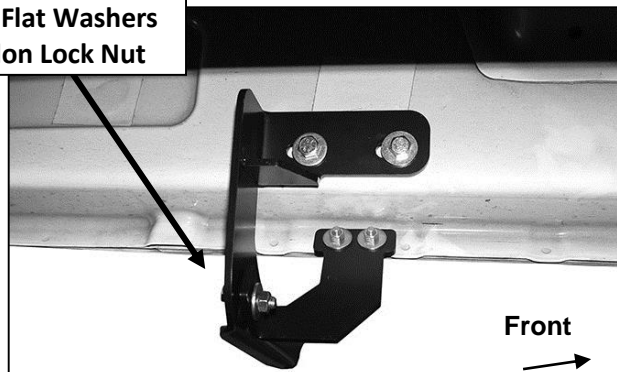

**(Fig 14) Driver/Left center Brackets installed**

6. Move to the rear location, **(Figure 15)**. Repeat **Step 3** to install the rear Mounting Bracket, **(Figure 16)**. Select the driver side rear Support Bracket. Repeat **Step 4** to attach the Support Bracket to the rear of the rear Bracket and factory holes, (if equipped), in the pinch weld, **(Figure 17)**. **IMPORTANT:** The driver/left rear Mounting Bracket and Support Bracket are the same as the Passenger/right front and center Brackets, (see illustration page 1).

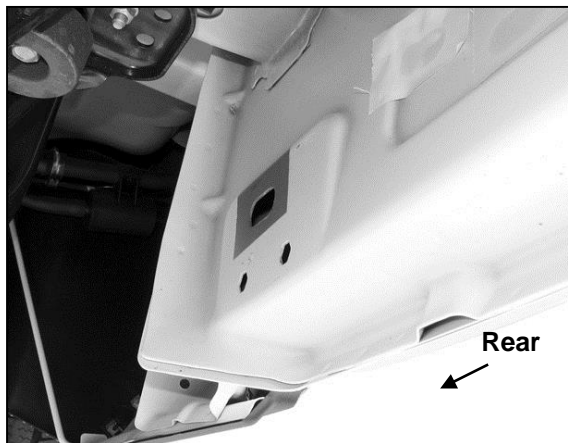

**(Fig 15) Driver/Left rear mounting location**

**IMPORTANT: 2009-2010 models without holes in pinch weld will require drilling 1/4" holes through pinch weld to attach Support Brackets. Do complete installation of Running Boards first and level Running Boards before drilling holes for Support Brackets.**

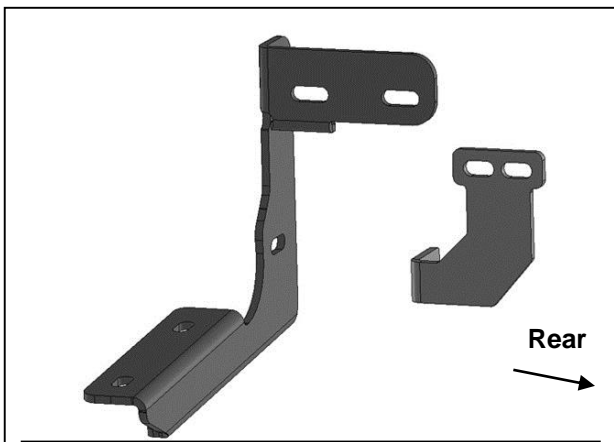

**(Fig 16) Driver/Left rear Mounting Brackets (same as passenger/right front and center)**



**(Fig 17) Driver/Left rear Brackets installed**

7. Once all (3) Brackets have been installed, select (1) Running Board. Place the Running Board on top of the Brackets. Select (3) 8mm Double Bolt Plates. Insert the Bolt Plates into the channels in the bottom of the Running Board closest to the Brackets, **(Figure 18)**. Lift the Running Board up and guide the studs through the Brackets.

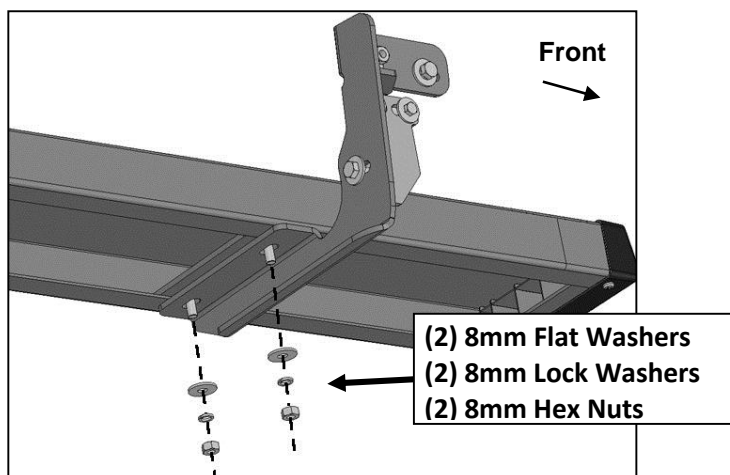

(Fig 18) Slide the 8mm Double Bolt Plate into channels

8. Attach the Running Board to the Brackets with (6) 8mm Flat Washers, (6) 8mm Lock Washers and (6) 8mm Hex Nuts, (Figures 19 & 20). **NOTE:** The Running Board is designed to fit close to the vehicle. It may be necessary to loosen the Bracket hardware and tilt the Brackets downward to insert the Running Board between the Brackets and the body. Do not tighten hardware at this time.

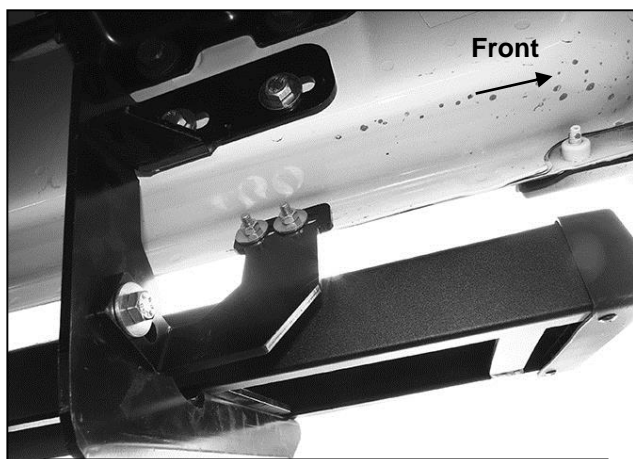

(Fig 19) Driver/left front Bracket assembly

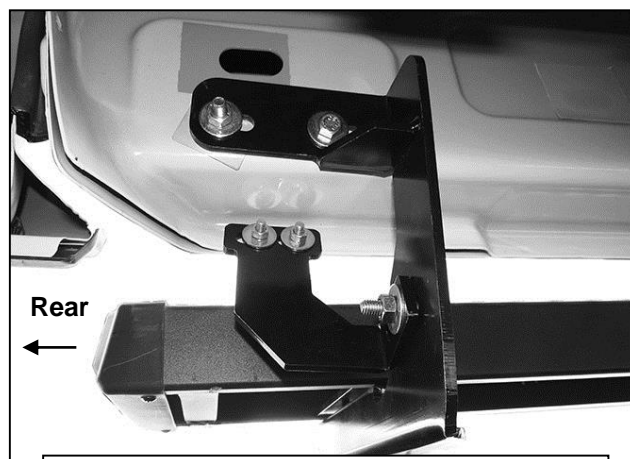

(Fig 20) Driver/left rear Bracket assembly (same as passenger/right front and center)

9. Properly level and adjust the Running Board and fully tighten all hardware. **NOTE:** Line up front of Running Board approximately 2" back from front wheel opening.

**2009-10 models requiring drilling for driver side Support Brackets:**

- Make sure the Running Board is level to the vehicle. Adjust and tighten all mounting hardware.
- Line up the slots on the Support Brackets with the back of the pinch weld. Mark the location of the slots onto the pinch weld.
- Drill (2) 1/4" holes through the pinch weld for each Support Bracket. **IMPORTANT:** Do not drill too close to the bottom edge of the pinch weld. Adjust the Brackets as necessary to move the slots up the body panel away from the edge. Drill the holes toward the outside of the marked slots.
- Attach each Support Bracket to pinch weld with (2) 6mm Hex Bolts, (4) 6mm Flat Washers and (2) 6mm Nylon Lock Nuts, (Figures 12, 14, 17, 19 & 20). Check for level and fully tighten all hardware.

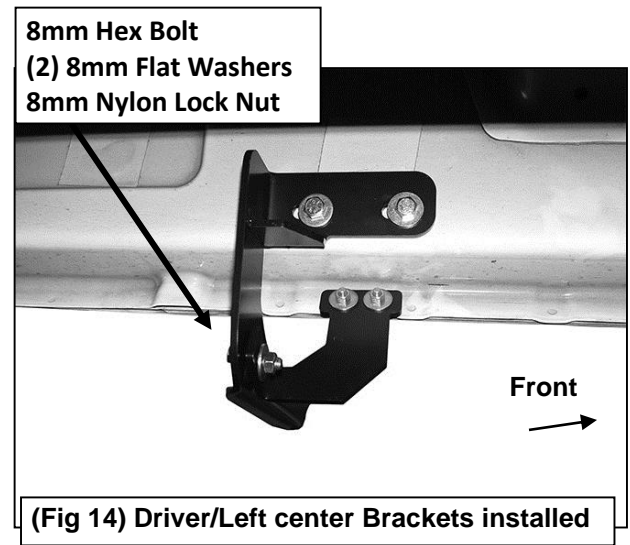
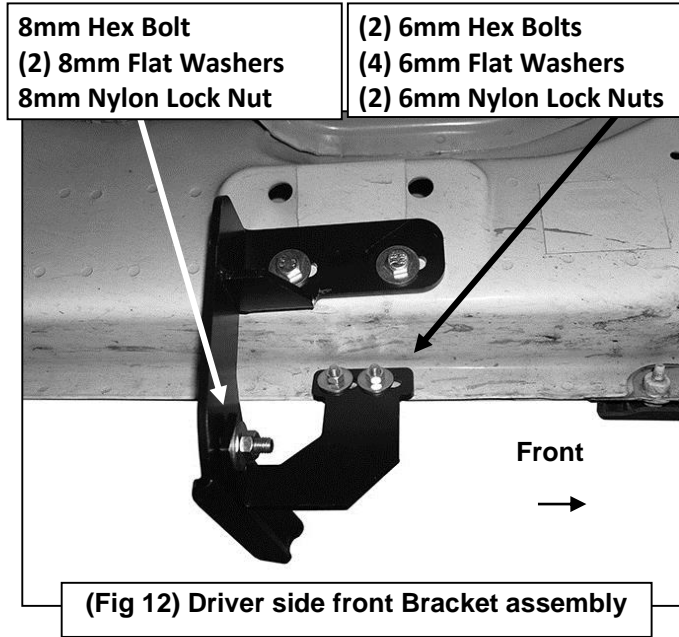

10. Move to the passenger side of the vehicle. Remove tape covering front, center and rear locations. Repeat **Steps 2—9** for passenger side Running Board installation. **NOTE:** Refer to the illustration on **Page 1** to identify the correct Mounting Bracket for each of the remaining locations.
11. Do periodic inspections to the installation to make sure that all hardware is secure and tight.



**PARTS IDENTIFICATION GUIDE**

**Driver Side tube packed using "Green" color foam sheet. Passenger Side tube packed using "White" color foam sheet**

No.	Parts Identification
1	Passenger / Right 'Rear' Bracket marked "PR"
2	Driver / Left 'Rear' Bracket marked "DR"
3	Passenger / Right 'Center' Bracket marked "PC"
4	Driver / Left 'Center' Bracket marked "DC"
5	Passenger / Right 'Front' Bracket marked "PF"
6	Driver / Left 'Front' Bracket marked "DF"

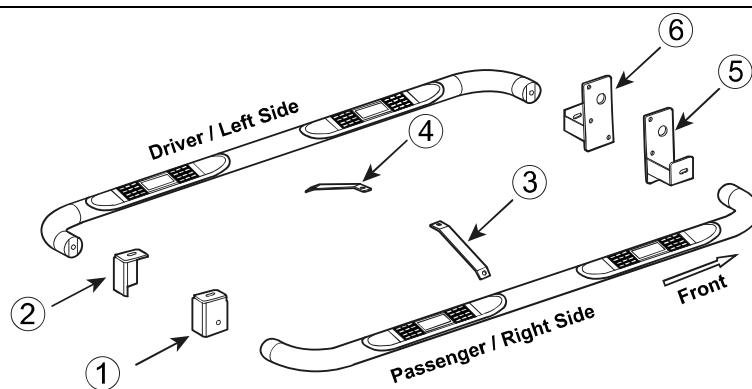
**Note:**

- This guide is to identify the parts and not a reference for part count.
- For part count, refer Parts List.
- Product / Bracket image is representative and actual design may vary.

**PRODUCT CARE**

- Periodically check the product to ensure all fasteners are tight and components are intact.
- Regular waxing is recommended to protect the finish of the product.
- **Use ONLY Non-Abrasive automotive wax.** Use of any soap, polish or wax that contains an abrasive is detrimental and can scratch the finish leading to corrosion.
- Aluminum polish may be used to polish small scratches and scuffs for **Stainless Steel finish.**
- Mild soap may be used to clean the product for both **Stainless Steel and Black finish.**

**FAQ's****1. Hardware's are not of correct size.**

*In GMC / Chevrolet truck model 2006 & up, customer needs to reuse the factory body bolts to install the bracket. If your vehicle is not GMC / Chevrolet 2006 & up, ensure that holes are not partially covered with any plastic grommet or rust? If it is, remove the plastic grommet & rust from the thread holes & re-try the installation.*

**2. Mounting Bracket are not getting Installed properly.**

*In some cases Illustration images shown in Installation manual may not be the exactly same as per actual vehicle images ,also if Driver / Passenger side mounting brackets are very identical in the design, suggest referring Parts Identification guide to avoid fitment issue.*

**3. Products are thumping / rattling after installation.**

*Ensure that all required mounting brackets / hardware's are installed & tighten correctly. Suggest using white lithium / regular grease between the metal to metal contact surfaces.*

**4. Side Bar is not aligning with vehicle / Step Pads are not aligning with vehicle doors.**

*Side bar may be interchanged or mounting brackets are not installed at the correct position in the vehicle. Refer Parts identification guide.*

**5. Missing / Excess Hardware.**

*Recheck hardware count as per the part list.*

**6. Product not installing properly.**

*Ensure make model year, cab length and bed size of your vehicle is listed in the application. All installation steps are followed correctly.*

**Check out these other TrailFX Products!!**

www.TrailFX.com

**BULL BAR****GRILLE GUARDS****BED RAILS****RUNNING BOARDS**

Keystone Automotive Operations Inc. (KAO) warrants this product to be free of defects in material and workmanship at the time of purchase by the original retail consumer. KAO disclaims any other warranties, express or implied, including the warranty of fitness for a particular purpose or an intended use. If the product is found to be defective, KAO may replace or repair the product at our option, when the product is returned prepaid, with proof of purchase. Alteration to, improper installation, or misuse of this product voids the warranty. KAO's liability is limited to repair or replacement of products found to be defective, and specifically excludes liability for any incidental or consequential loss or damage.