

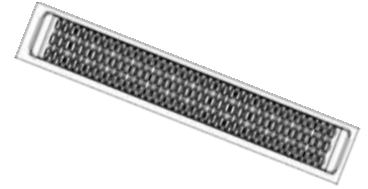

Aggressive Running Board

Part No. RBA008TI



Fits: **2015-Current**
2017-Current

Ford F150 Regular Cab
F250/350/450/550 Super Duty Regular Cab



ASSISTANCE IS RECOMMENDED.



REMOVE CONTENTS FROM BOX. VERIFY ALL PARTS ARE PRESENT.



READ INSTRUCTIONS CAREFULLY BEFORE STARTING INSTALLATION.

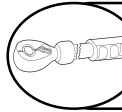

DO NOT OVER TORQUE. STANDARD OPERATING LOAD FOR TIGHTEN BODY MOUNT NUTS & BOLTS VARIES FROM **45 TO 65 FOOT POUND**.



60-180 min



Cutting Required



Drilling Not Required



support@trailfx.com



1 866 638 4870



POLISHED STAINLESS STEEL - LIMITED LIFETIME
POWDER COATED BLACK - 3 YEARS

PARTS LIST:

Qty	Part Description	Qty	Part Description
2	Running Boards	20	8mm x 24mm x 2mm Flat Washers
4	Mounting Brackets (left or right)	8	8mm Lock Washers
4	8mm Double Bolt Plates	8	8mm Hex Nuts
12	8mm Plastic Retainers	12	8-1.25mm Nylon Lock Nuts

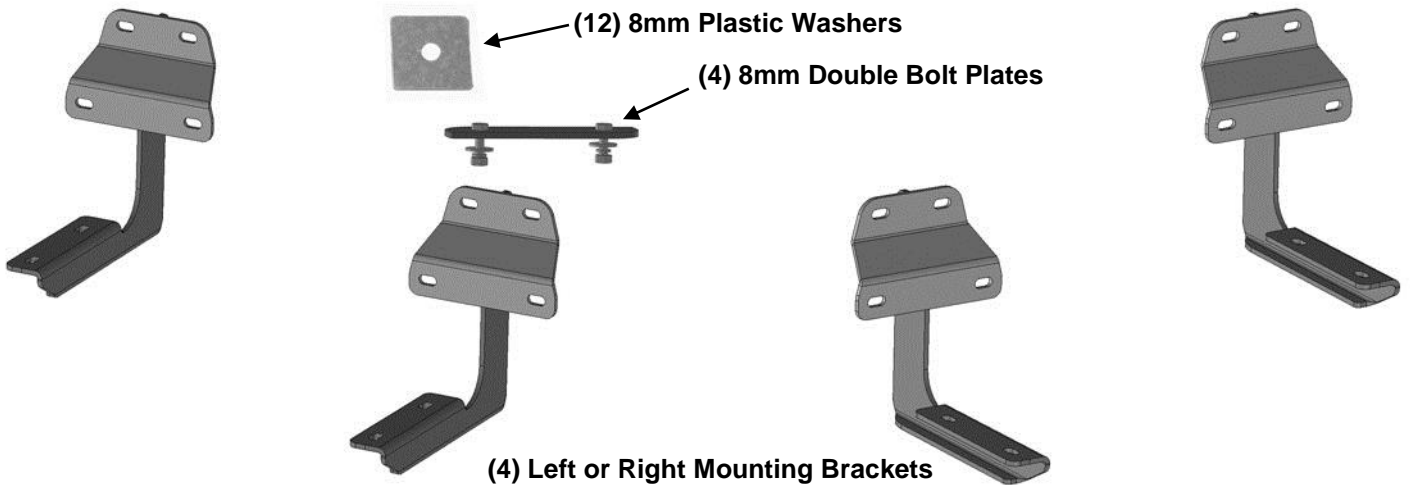

INSTALLATION PROCEDURE:

REMOVE CONTENTS FROM BOX. VERIFY ALL PARTS ARE PRESENT. READ INSTRUCTIONS CAREFULLY BEFORE STARTING INSTALLATION. ASSISTANCE IS RECOMMENDED.

1. Start the installation under the passenger/right side of the vehicle. Locate the front factory running board mounting location, (threaded studs), along the inner side of the body, **(Figure 1)**.

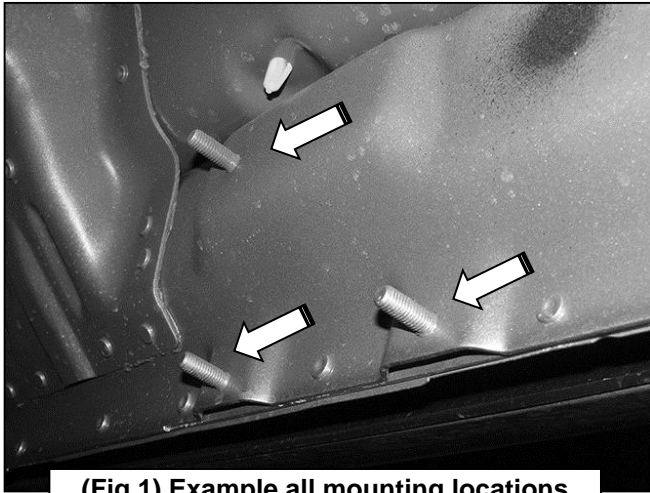

(Fig 1) Example all mounting locations

2. Slide (1) Plastic Washer over each of the (3) factory mounting studs in the body panel, **(Figures 2—4)**. **IMPORTANT:** The Plastic Washers are designed to prevent corrosion between the aluminum body panel and the steel mounting brackets. **Do not install the Brackets without the Plastic Washers.**

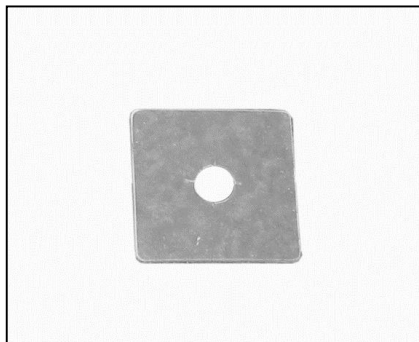

(Fig 2) Plastic Insulation Washer

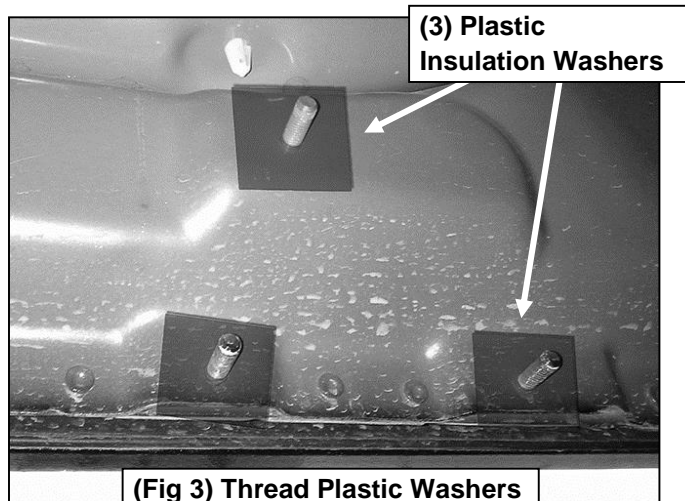

(Fig 3) Thread Plastic Washers onto all mounting studs

(3) 8mm Flat Washers
(3) 8-1.25mm Nylon Lock Nuts

(3) 8mm Plastic Washers

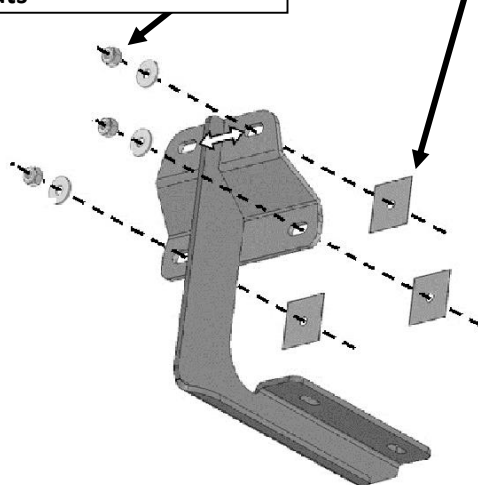

(Fig 4) Typical Bracket installation

3. Select (1) Mounting Bracket. **NOTE:** All (4) Brackets are universal and will fit left or right side. Attach the Mounting Bracket to the (3) factory studs with (3) 8mm Flat Washers, and (3) 8mm Nylon Lock Nuts, **(Figures 4 & 5)**. Leave brackets loose at this time.

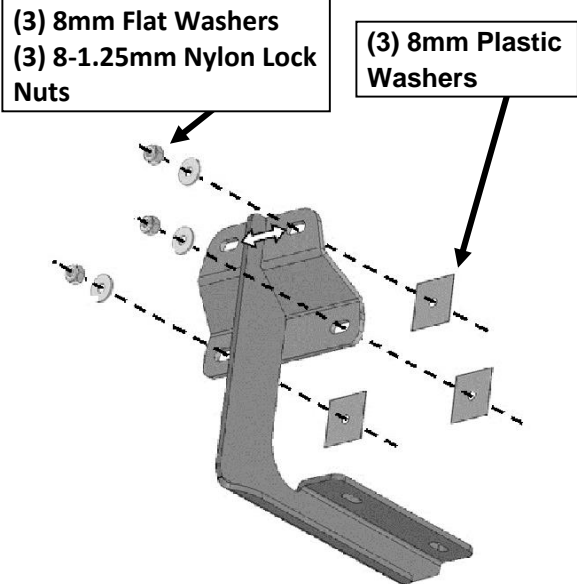

(Fig 4) Typical Bracket installation



(Fig 5) Passenger/right front Bracket installed

4. Move along the cab toward the rear mounting location. Repeat **Steps 1—3** to install the rear passenger/right side Bracket, (Figure 6).

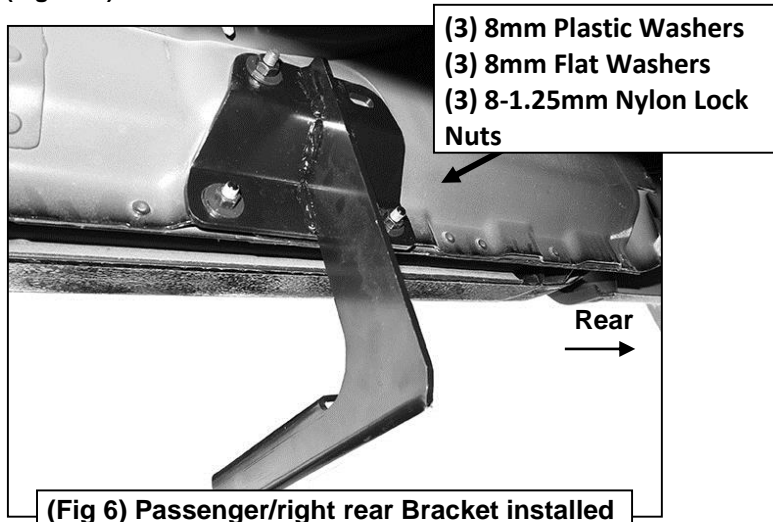

(Fig 6) Passenger/right rear Bracket installed

5. Carefully unwrap (1) Running Board. Place the Running Board on top of the Brackets. Locate the channels in the bottom of the Running Board. Select (2) 8mm Double Bolt Plates, (Figure 7). Insert the Bolt Plates into the channels in the bottom of the Running Board closest to the Brackets. Lift the Running Board up and guide the studs down through the Brackets, (Figure 8).



(Fig 7) 8mm Double Bolt Plate

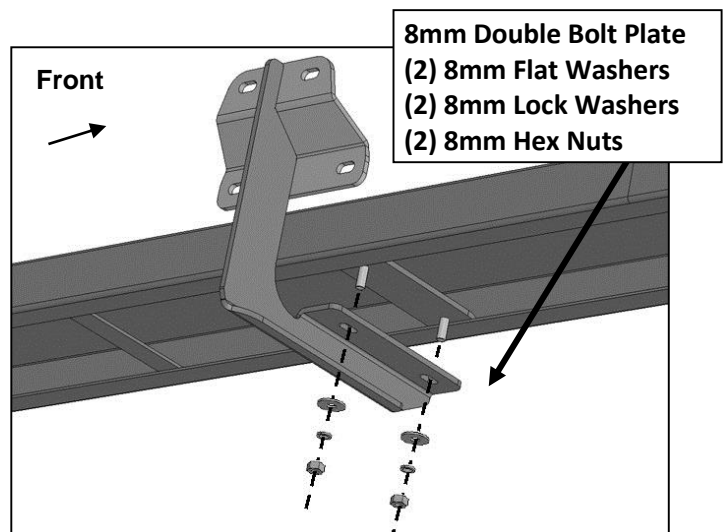

(Fig 8) Slide 6mm Double Bolt Plates into track on bottom of Running Board

6. Attach the Running Board to the Brackets with (4) 8mm Flat Washers, (4) 8mm Lock Washers and (4) 8mm Hex Nuts, **(Figures 8—10)**. **NOTE:** The Running Board is designed to fit close to the vehicle. It may be necessary to loosen the Bracket hardware slightly and tilt the Brackets downward to insert the Running Board between the Brackets and the body.

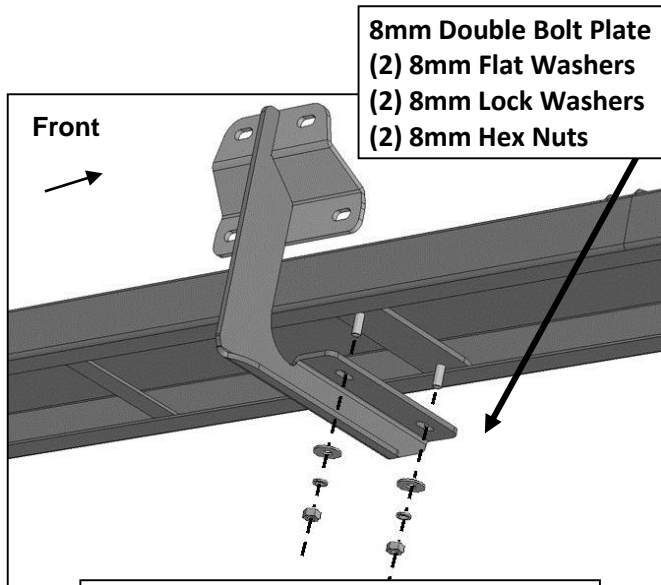

(Fig 8) Slide 6mm Double Bolt Plates into track on bottom of Running Board

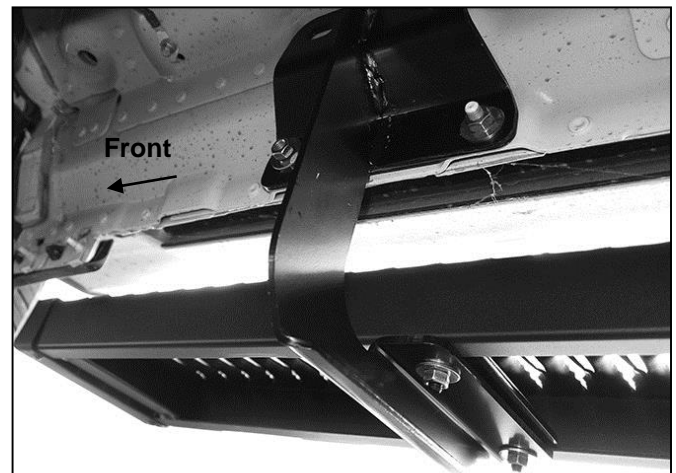

(Fig 9) Passenger/right front complete installation

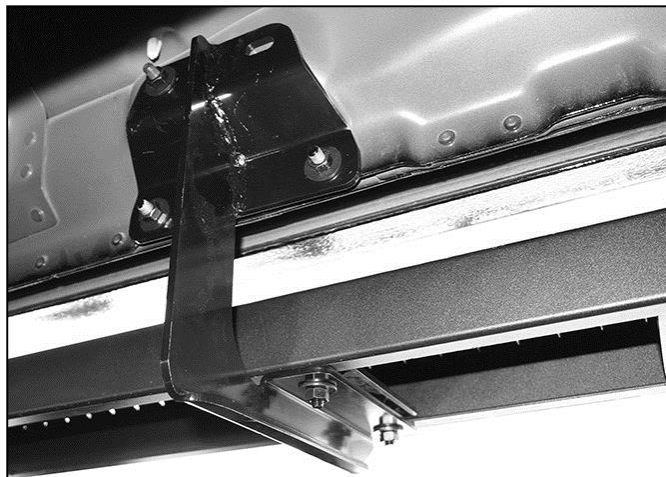

(Fig 10) Passenger/right rear complete installation

7. Level and adjust the Running Board as necessary and fully tighten all hardware. **NOTE:** Line up front end of Running Board approximately 2" back from wheel opening or as desired.
8. Repeat **Steps 1—7** for the driver/left Running Board installation.
9. Do periodic inspections to the installation to make sure that all hardware is secure and tight.



PARTS IDENTIFICATION GUIDE

Driver Side tube packed using "Green" color foam sheet. Passenger Side tube packed using "White" color foam sheet

No.	Parts Identification
1	Passenger / Right 'Rear' Bracket marked "PR"
2	Driver / Left 'Rear' Bracket marked "DR"
3	Passenger / Right 'Center' Bracket marked "PC"
4	Driver / Left 'Center' Bracket marked "DC"
5	Passenger / Right 'Front' Bracket marked "PF"
6	Driver / Left 'Front' Bracket marked "DF"

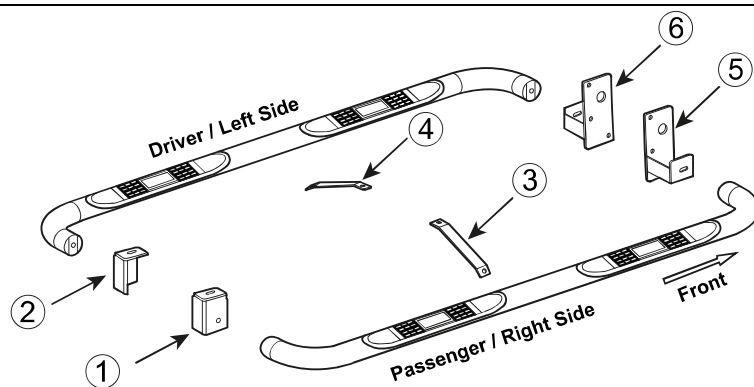
**Note:**

- > This guide is to identify the parts and not a reference for part count.
- > For part count, refer Parts List.
- > Product / Bracket image is representative and actual design may vary.

PRODUCT CARE

- Periodically check the product to ensure all fasteners are tight and components are intact.
- Regular waxing is recommended to protect the finish of the product.
- **Use ONLY Non-Abrasive automotive wax.** Use of any soap, polish or wax that contains an abrasive is detrimental and can scratch the finish leading to corrosion.
- Aluminum polish may be used to polish small scratches and scuffs for **Stainless Steel finish.**
- Mild soap may be used to clean the product for both **Stainless Steel and Black finish.**

FAQ's**1. Hardware's are not of correct size.**

In GMC / Chevrolet truck model 2006 & up, customer needs to reuse the factory body bolts to install the bracket. If your vehicle is not GMC / Chevrolet 2006 & up, ensure that holes are not partially covered with any plastic grommet or rust? If it is, remove the plastic grommet & rust from the thread holes & re-try the installation.

2. Mounting Bracket are not getting Installed properly.

In some cases Illustration images shown in Installation manual may not be the exactly same as per actual vehicle images ,also if Driver / Passenger side mounting brackets are very identical in the design, suggest referring Parts Identification guide to avoid fitment issue.

3. Products are thumping / rattling after installation.

Ensure that all required mounting brackets / hardware's are installed & tighten correctly. Suggest using white lithium / regular grease between the metal to metal contact surfaces.

4. Side Bar is not aligning with vehicle / Step Pads are not aligning with vehicle doors.

Side bar may be interchanged or mounting brackets are not installed at the correct position in the vehicle. Refer Parts identification guide.

5. Missing / Excess Hardware.

Recheck hardware count as per the part list.

6. Product not installing properly.

Ensure make model year, cab length and bed size of your vehicle is listed in the application. All installation steps are followed correctly.

Check out these other TrailFX Products!!

www.TrailFX.com

**BULL BAR****GRILLE GUARDS****BED RAILS****RUNNING BOARDS**

Keystone Automotive Operations Inc. (KAO) warrants this product to be free of defects in material and workmanship at the time of purchase by the original retail consumer. KAO disclaims any other warranties, express or implied, including the warranty of fitness for a particular purpose or an intended use. If the product is found to be defective, KAO may replace or repair the product at our option, when the product is returned prepaid, with proof of purchase. Alteration to, improper installation, or misuse of this product voids the warranty. KAO's liability is limited to repair or replacement of products found to be defective, and specifically excludes liability for any incidental or consequential loss or damage.