

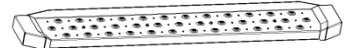

Running Board

Part No. RBW07B



Fits: 1999 - Current

Ford F250/350/450/550 Super duty Super Cab



Assistance Is Recommended. On Models With Def Tank, Select A Flat, Level Area for Installation



60-180 min

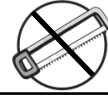

Cutting Not Required



Drilling Not Required



REMOVE CONTENTS FROM BOX. VERIFY ALL PARTS ARE PRESENT.



support@trailfx.com



READ INSTRUCTIONS CAREFULLY BEFORE STARTING INSTALLATION.



1 866 638 4870

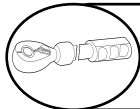

DO NOT OVER TORQUE. STANDARD OPERATING LOAD FOR TIGHTEN BODY MOUNT NUTS & BOLTS VARIES FROM 45 TO 65 FOOT POUND.



POLISHED STAINLESS STEEL - LIMITED LIFETIME
POWDER COATED BLACK - 3 YEARS

PARTS LIST:

Qty	Part Description	Qty	Part Description
2	Steel Running Boards	6	8-1.25mm Nylon Lock Nuts
6	Universal Mounting Brackets (left of right)	6	6mm Double Bolt Plates
6	8-1.25mm Clip-Nuts	12	6mm x 22mm OD x 2mm Flat Washers
12	8-1.25mm x 25mm Hex Bolts	12	6mm Lock Washers
18	8mm x 24mm x 2mm Flat Washer	12	6mm Hex Nuts
6	8mm Lock Washers		

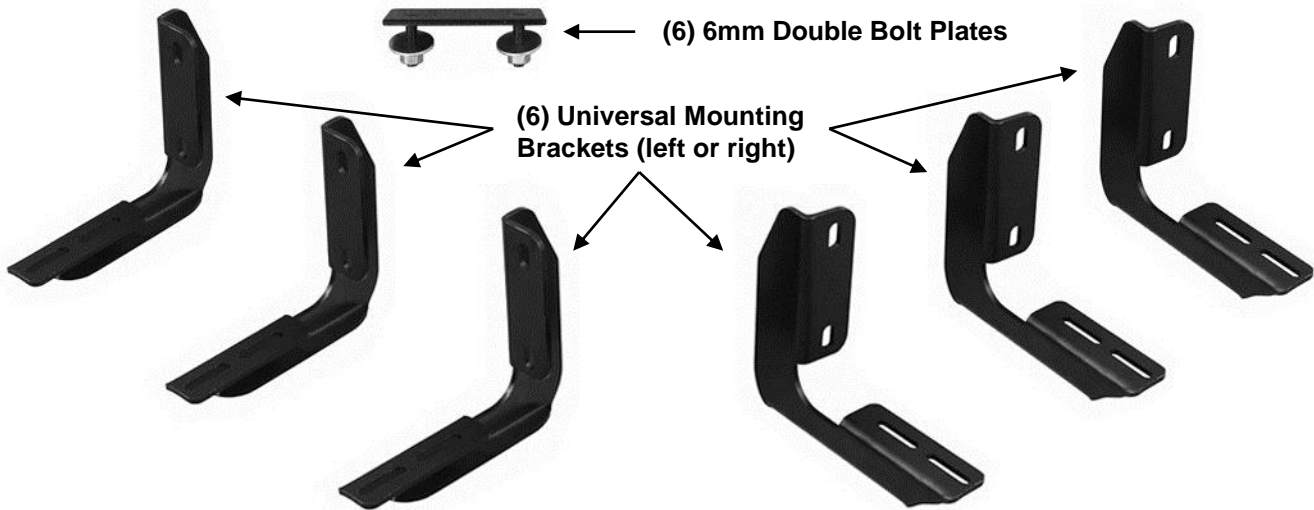

INSTALLATION PROCEDURE:

1. Starting on the front-driver side of the vehicle, locate the (2) holes through the bottom of the body panel, (pinch weld-**Figure 1A**). Next locate the rectangular opening and (2) small holes in the inner body panel directly above the holes in the pinch weld, (**Figures 1B & 2**). **NOTE:** The holes in the inner panel may be covered with sealing tape or insulation, remove as required.
2. Slide (1) 8mm Clip Nut into the rectangular opening with the nut towards the inside. Line up the threaded nut on the clip with the round hole toward the rear, (**Figure 2**).
3. Select (1) Mounting Bracket. Attach the top of the Bracket to the Clip Nut with (1) 8mm x 25mm Hex Bolt, (1) 8mm Lock Washer and (1) 8mm Flat Washer, (**Figure 3**). Leave loose at this time. Line up the lower hole in the Bracket with the hole through the pinch weld. Bolt the Bracket to the pinch weld with (1) 8mm x 25mm Hex Bolt, (2) 8mm Flat Washers and (1) 8mm Nylon Lock Nut, (**Figures 3 & 8**). Snug but do not fully tighten Bracket hardware.
4. Move to the center mounting location, (**Figure 4**). **NOTE:** There are (4) factory mounting locations along the inner body panel. Installation will use the 1st, 3rd and 4th mounting locations only. Refer to **Figures 1A & 1B** to help identify the correct locations. Repeat **Steps 2—4** to install the center Bracket in the rear set of mounting holes, (**Figure 5**).
5. Move toward the rear of the cab. Locate the last pair of holes along the pinch weld. Use **Figure 1B** to determine the correct mounting location for the rear Bracket. Repeat **Steps 2—4** to install (1) Mounting Bracket in the rear pair of holes in the rear location, (**Figure 9**).
6. Once the (3) Brackets have been fully installed, select (1) Running Board. Place the Running Board on top of the Brackets. Locate the channels in the bottom of the Running Board. Select (3) 6mm Double Bolt Plates, (**Figure 6**). Insert the Bolt Plates into the channels in the bottom of the Running Board closest to the Brackets, (**Figure 7**). Lift the Board up and guide the studs through the Brackets.
7. Attach the Running Board to the Brackets with (6) 6mm Flat Washers, (6) 6mm Lock Washers and (6) 6mm Hex Nuts, (**Figures 8 & 9**). **NOTE:** The Running Board is designed to fit close to the vehicle. It may be necessary to loosen the Bracket hardware slightly and tilt the Brackets downward to insert the Running Board between the Brackets and the body.
8. Level and adjust the Running Board as necessary and fully tighten all hardware.
9. Repeat **Steps 2—9** for passenger side Running Board installation.
10. Do periodic inspections to the installation to make sure that all hardware is secure and tight.

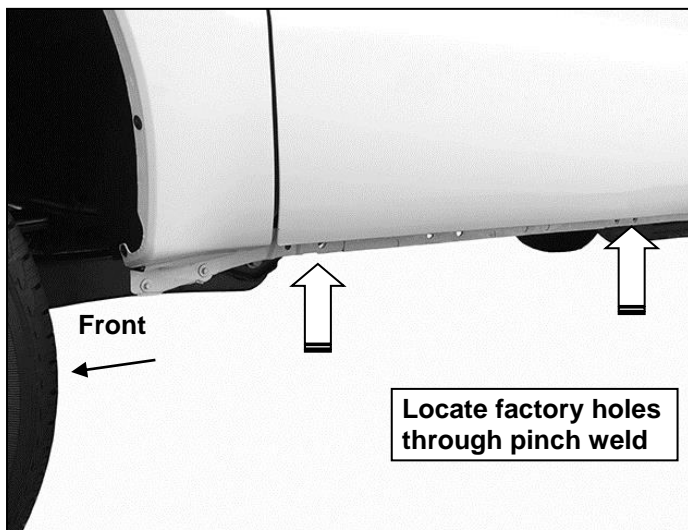

(Fig 1A) Driver/left front and center mounting locations

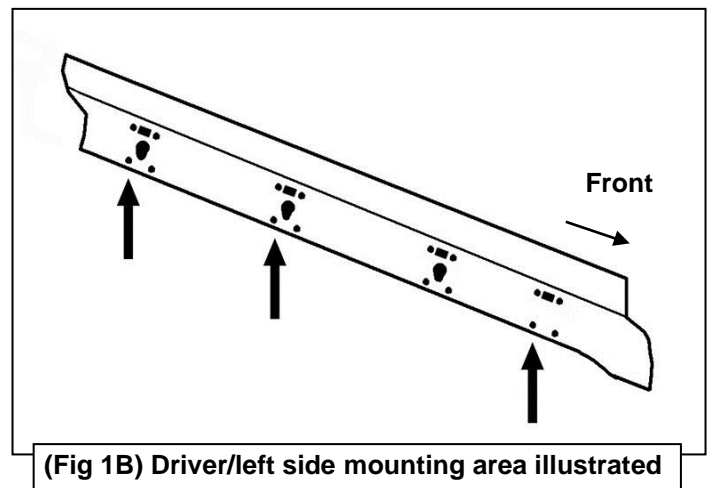

(Fig 1B) Driver/left side mounting area illustrated

8mm Clip Nut

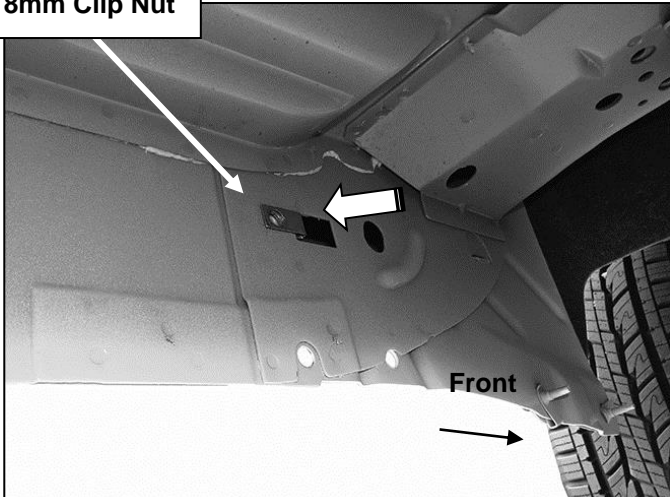

(Fig 2) Slide 8mm Clip Nut into rectangular opening

8mm Clip Nut
8mm x 25mm Hex Bolt
8mm Lock Washer
8mm Flat Washer

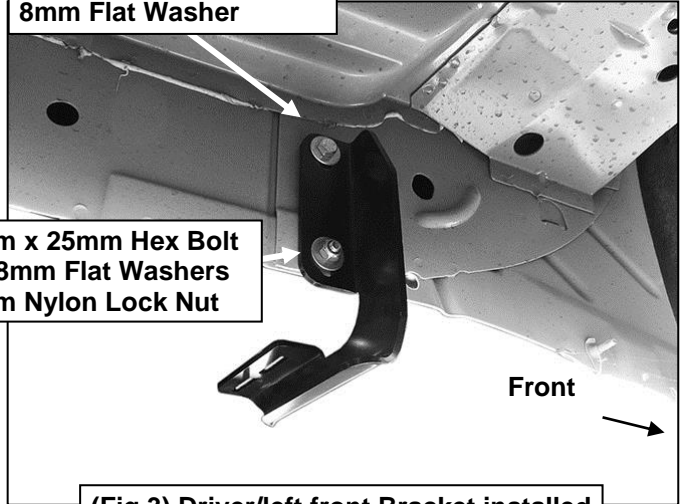

(Fig 3) Driver/left front Bracket installed

8mm Clip Nut

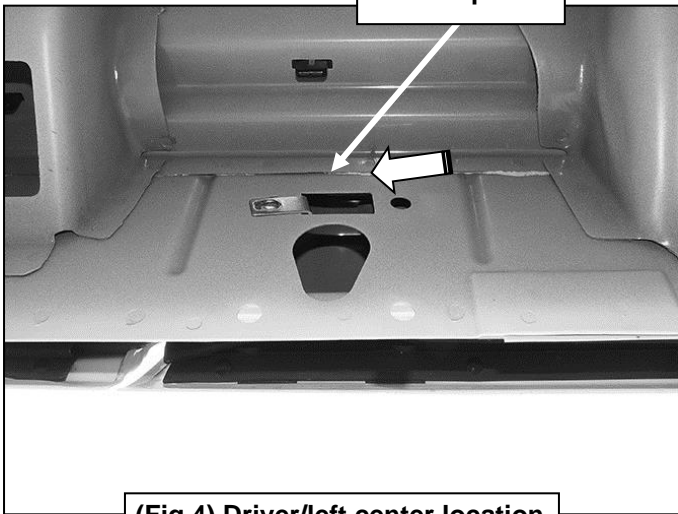

(Fig 4) Driver/left center location

8mm Clip Nut
8mm x 25mm Hex Bolt
8mm Lock Washer
8mm Flat Washer

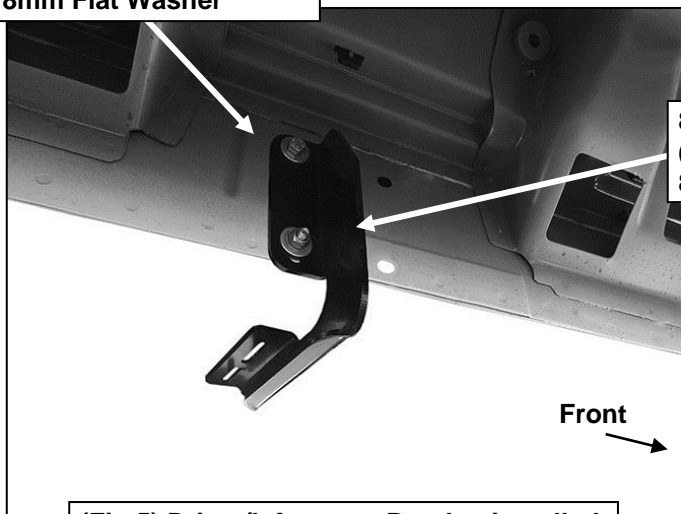

(Fig 5) Driver/left center Bracket installed

8mm x 25mm Hex Bolt
(2) 8mm Flat Washers
8mm Nylon Lock Nut



(Fig 6) 6mm Double Bolt Plate

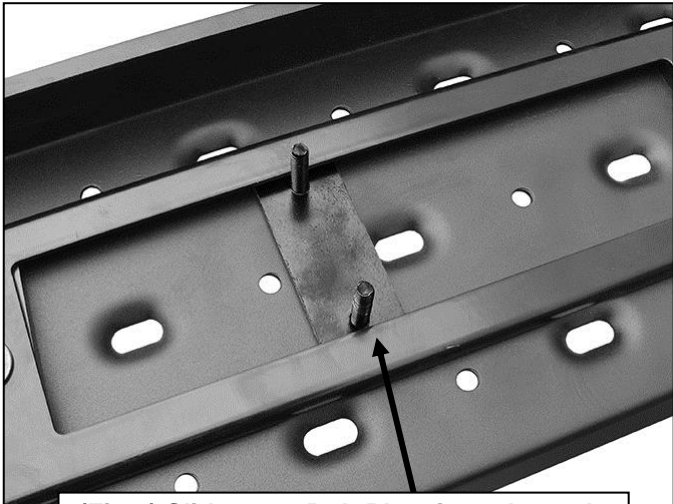

(Fig 7) Slide 6mm Bolt Plate into channels

- (2) 6mm Flat Washers
- (2) 6mm Lock Washers
- (2) 6mm Hex Nuts

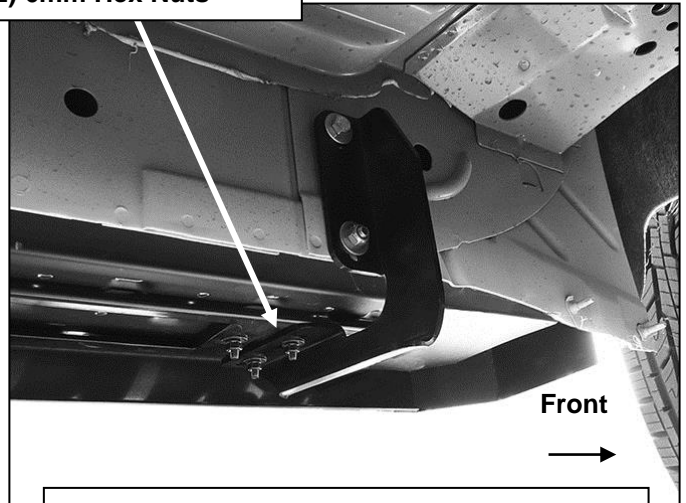

(Fig 8) Driver/left side front Bracket installed

- (2) 6mm Flat Washers
- (2) 6mm Lock Washers
- (2) 6mm Hex Nuts

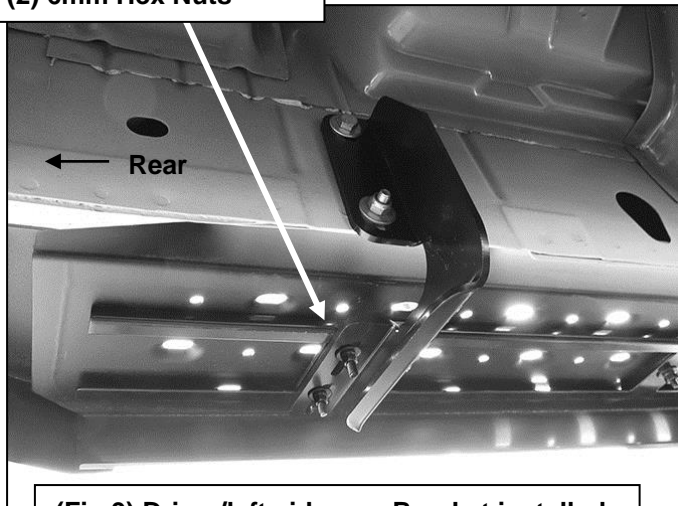

(Fig 9) Driver/left side rear Bracket installed



Complete Installation

PARTS IDENTIFICATION GUIDE

Driver Side tube packed using "Green" color foam sheet. Passenger Side tube packed using "White" color foam sheet

No.	Parts Identification
1	Passenger / Right 'Rear' Bracket marked "PR"
2	Driver / Left 'Rear' Bracket marked "DR"
3	Passenger / Right 'Center' Bracket marked "PC"
4	Driver / Left 'Center' Bracket marked "DC"
5	Passenger / Right 'Front' Bracket marked "PF"
6	Driver / Left 'Front' Bracket marked "DF"

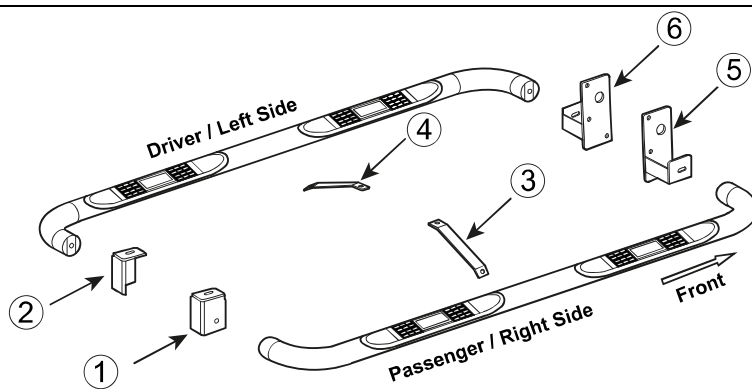
**Note:**

- This guide is to identify the parts and not a reference for part count.
- For part count, refer Parts List.
- Product / Bracket image is representative and actual design may vary.

PRODUCT CARE

- Periodically check the product to ensure all fasteners are tight and components are intact.
- Regular waxing is recommended to protect the finish of the product.
- **Use ONLY Non-Abrasive automotive wax.** Use of any soap, polish or wax that contains an abrasive is detrimental and can scratch the finish leading to corrosion.
- Aluminum polish may be used to polish small scratches and scuffs for **Stainless Steel finish.**
- Mild soap may be used to clean the product for both **Stainless Steel and Black finish.**

FAQ's**1. Hardware's are not of correct size.**

In GMC / Chevrolet truck model 2006 & up, customer needs to reuse the factory body bolts to install the bracket. If your vehicle is not GMC / Chevrolet 2006 & up, ensure that holes are not partially covered with any plastic grommet or rust? If it is, remove the plastic grommet & rust from the thread holes & re-try the installation.

2. Mounting Bracket are not getting Installed properly.

In some cases Illustration images shown in Installation manual may not be the exactly same as per actual vehicle images ,also if Driver / Passenger side mounting brackets are very identical in the design, suggest referring Parts Identification guide to avoid fitment issue.

3. Products are thumping / rattling after installation.

Ensure that all required mounting brackets / hardware's are installed & tighten correctly. Suggest using white lithium / regular grease between the metal to metal contact surfaces.

4. Side Bar is not aligning with vehicle / Step Pads are not aligning with vehicle doors.

Side bar may be interchanged or mounting brackets are not installed at the correct position in the vehicle. Refer Parts identification guide.

5. Missing / Excess Hardware.

Recheck hardware count as per the part list.

6. Product not installing properly.

Ensure make model year, cab length and bed size of your vehicle is listed in the application. All installation steps are followed correctly.

Check out these other TrailFX Products!!

www.TrailFX.com

**BULL BAR****GRILLE GUARDS****BED RAILS****RUNNING BOARDS**

Keystone Automotive Operations Inc. (KAO) warrants this product to be free of defects in material and workmanship at the time of purchase by the original retail consumer. KAO disclaims any other warranties, express or implied, including the warranty of fitness for a particular purpose or an intended use. If the product is found to be defective, KAO may replace or repair the product at our option, when the product is returned prepaid, with proof of purchase. Alteration to, improper installation, or misuse of this product voids the warranty. KAO's liability is limited to repair or replacement of products found to be defective, and specifically excludes liability for any incidental or consequential loss or damage.