



Display Rack

Part No. WD1000GG

Fits: **All Years -****Grille Guard Display Rack**

60-180 min

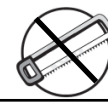
Cutting Not
RequiredDrilling Not
Required

REMOVE CONTENTS FROM BOX. VERIFY ALL PARTS ARE PRESENT.

support@trailfx.com

READ INSTRUCTIONS CAREFULLY BEFORE STARTING INSTALLATION.

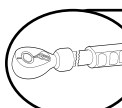

1 866 638 4870

DO NOT OVER TORQUE. STANDARD OPERATING LOAD FOR TIGHTEN
BODY MOUNT NUTS & BOLTS VARIES FROM **45** TO **65** FOOT POUND.

POWDER COATED BLACK - 3 YEARS

PARTS LIST:

Qty	Part Description	Qty	Part Description
1	Bottom Stand	2	M10 Hex Nut
1	Bracket	8	M8 x 20mm Hex Bolt
2	Connect Parcel	8	8mm Flat washers
2	Top Hook	8	8mm Spring washers
2	M10 x 25mm Hex Bolt	1	S=5 Wrench
4	10mm Flat Washers	2	10mm Spring washer

Notice

1. The figures here are for reference only and may have differences between the actual product you received,
2. however they share the same assembly way.
3. Please read the instruction completely for easy installation

INSTALLATION PROCEDURE

1. Refer to the fig1 to install the bottom stand and bracket with parts.
2. Refer to the fig1 to install the connect parcel to the display rack with parts.

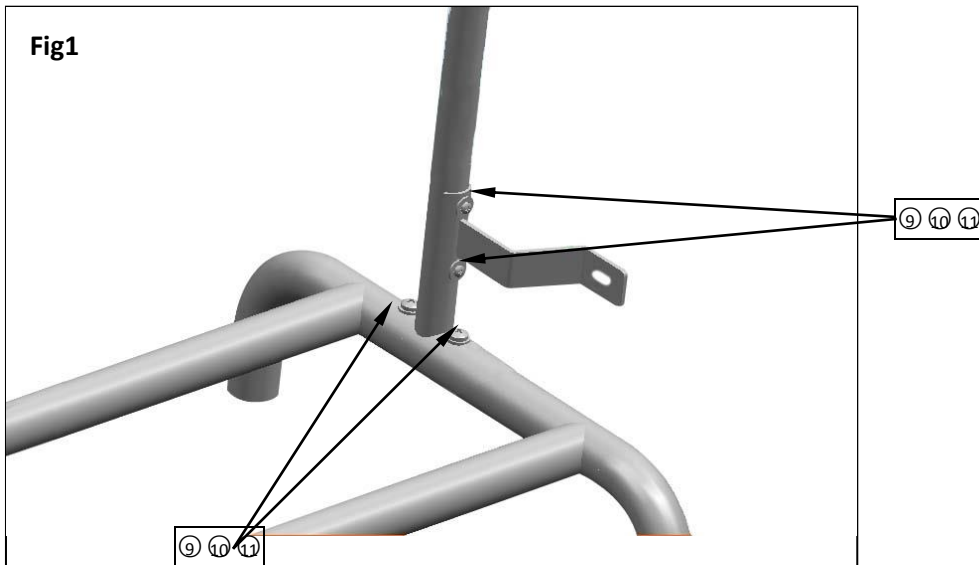

3. Refer to the fig2 to install the top hook to the display rack.



3. Refer to the fig3 to install the grille guard to the connect parcel and top hook.

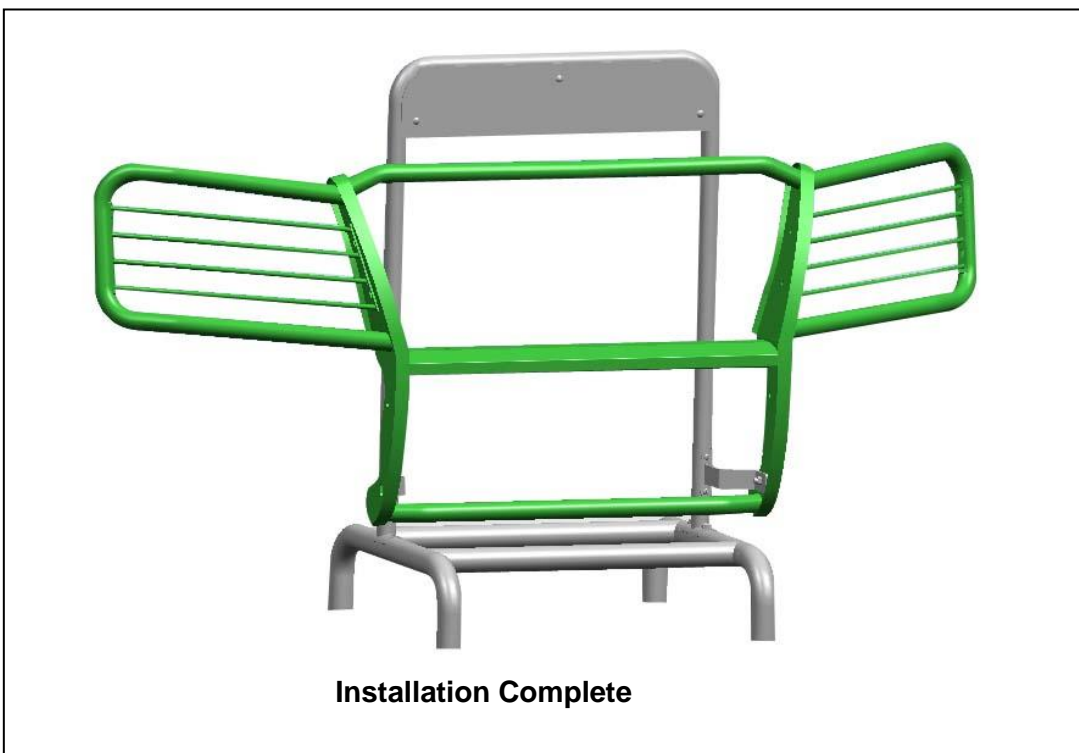
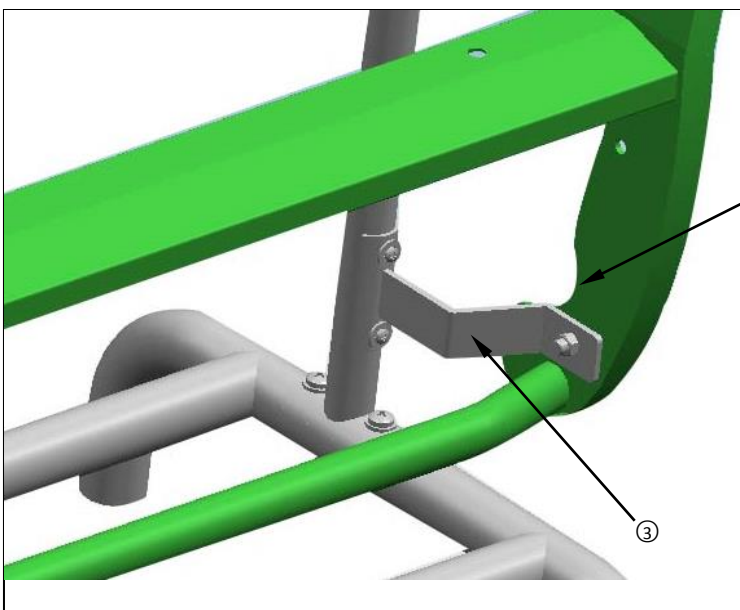
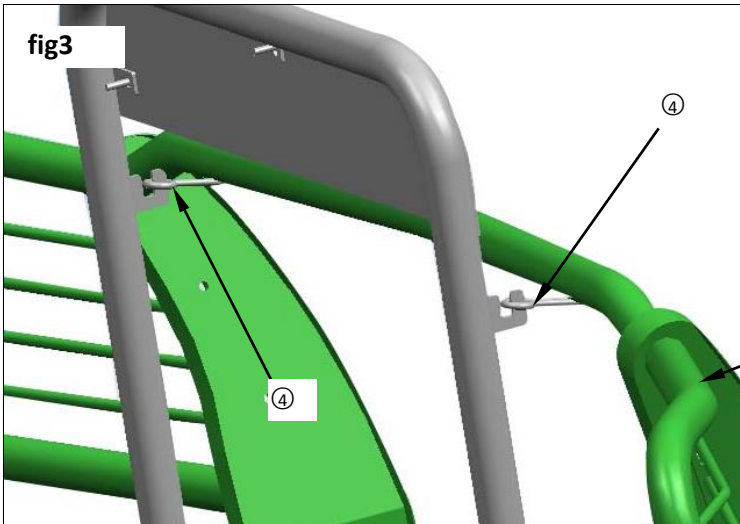

PRODUCT CARE

- Periodically check the product to ensure all fasteners are tight and components are intact.
- Regular waxing is recommended to protect the finish of the product.
- **Use ONLY Non-Abrasive automotive wax.** Use of any soap, polish or wax that contains an abrasive is detrimental and can scratch the finish leading to corrosion.
- Aluminum polish may be used to polish small scratches and scuffs for **Stainless Steel finish.**
- Mild soap may be used to clean the product for both **Stainless Steel and Black finish.**

FAQ's**1. Hardware's are not of correct size.**

In GMC / Chevrolet truck model 2006 & up, customer needs to reuse the factory body bolts to install the bracket. If your vehicle is not GMC / Chevrolet 2006 & up, ensure that holes are not partially covered with any plastic grommet or rust? If it is, remove the plastic grommet & rust from the thread holes & re-try the installation.

2. Mounting Bracket are not getting Installed properly.

In some cases Illustration images shown in Installation manual may not be the exactly same as per actual vehicle images ,also if Driver / Passenger side mounting brackets are very identical in the design, suggest referring Parts Identification guide to avoid fitment issue.

3. Products are thumping / rattling after installation.

Ensure that all required mounting brackets / hardware's are installed & tighten correctly. Suggest using white lithium / regular grease between the metal to metal contact surfaces.

4. Side Bar is not aligning with vehicle / Step Pads are not aligning with vehicle doors.

Side bar may be interchanged or mounting brackets are not installed at the correct position in the vehicle. Refer Parts identification guide.

5. Missing / Excess Hardware.

Recheck hardware count as per the part list.

6. Product not installing properly.

Ensure make model year, cab length and bed size of your vehicle is listed in the application. All installation steps are followed correctly.

Check out these other TrailFX Products!!

www.TrailFX.com



SIDE BAR



HEADACHE RACKS



RUNNING BOARDS



ROCKER GUARDS

Keystone Automotive Operations Inc. (KAO) warrants this product to be free of defects in material and workmanship at the time of purchase by the original retail consumer. KAO disclaims any other warranties, express or implied, including the warranty of fitness for a particular purpose or an intended use. If the product is found to be defective, KAO may replace or repair the product at our option, when the product is returned prepaid, with proof of purchase. Alteration to, improper installation, or misuse of this product voids the warranty. KAO's liability is limited to repair or replacement of products found to be defective, and specifically excludes liability for any incidental or consequential loss or damage.