

INSTALLATION INSTRUCTIONS

MAX WINCH TRAY



APPLICATION:
2018-2020 Jeep JL Wrangler (Excl. 2018 JK), 2020 Jeep Gladiator
PART NUMBER:
46-23925

ITEM	QUANTITY	DESCRIPTION	TOOLS NEEDED
1	1	WINCH TRAY	13MM WRENCH
2	1	DRIVER MOUNTING BRACKET	13MM SOCKET
3	1	PASSENGER MOUNTING BRACKET	17MM WRENCH
4	1	FAIRLEAD PLATE	17MM SOCKET
5	4	M8 BUTTON HEAD BOLT	RATCHET
6	4	M8 FLAT WASHER	TORQUE WRENCH
7	4	M8 SERRATED FLANGE NUT	PRY TOOL
8	4	M10 BUTTON HEAD BOLT	
9	4	M10 HEX NUT	
10	4	M10 FLAT WASHER	
11	4	M10 SPLIT LOCK WASHER	

ANTI-SEIZE LUBRICANT MUST BE USED ON ALL STAINLESS STEEL FASTENERS TO PREVENT THREAD DAMAGE AND GALLING

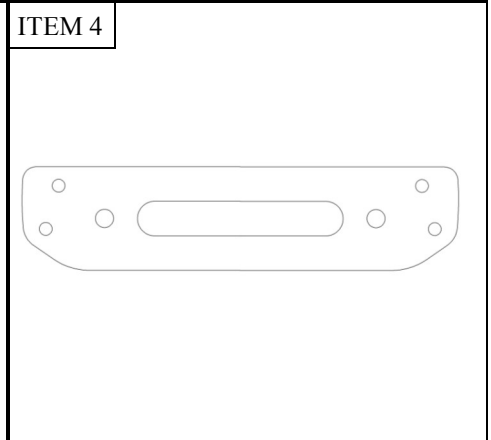
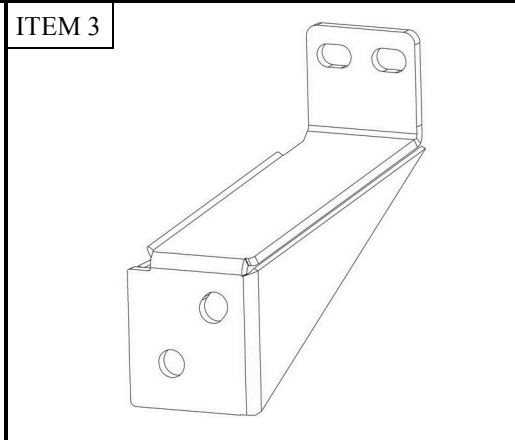
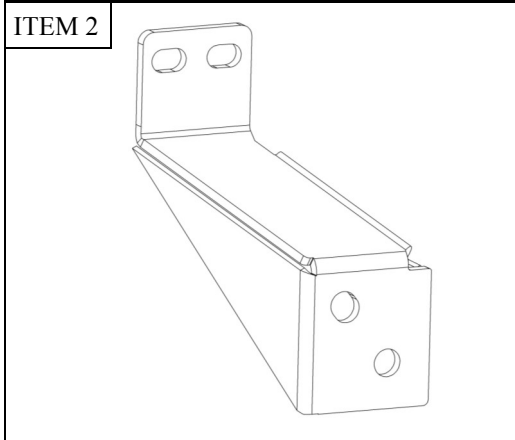
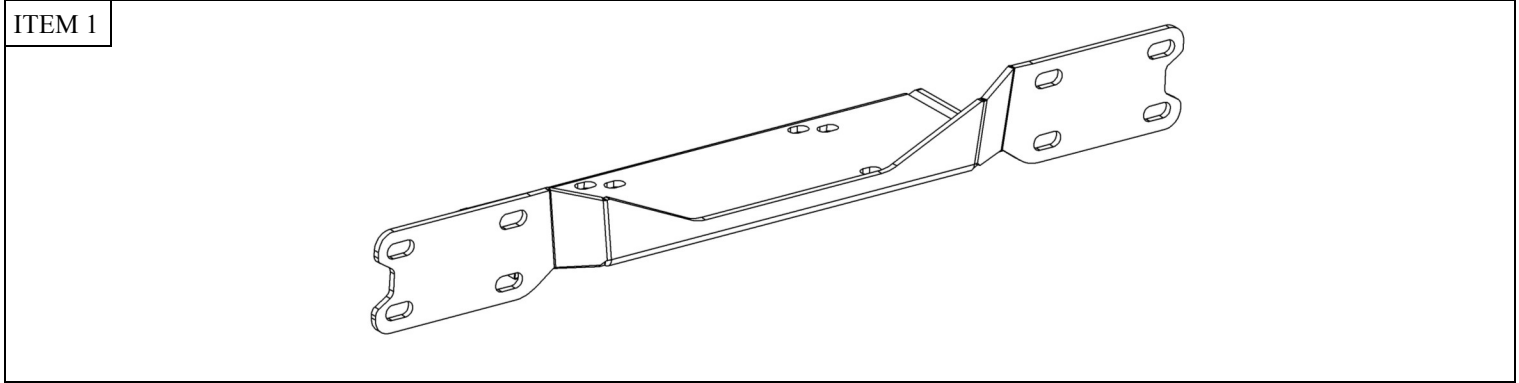

PROCEDURE

1. Remove contents from box, verify if all parts listed are present and free from damage.
Carefully read and understand all instructions before attempting installation.
Failure to identify damage before installation could lead to a rejection of any claim.

2. Remove Stock Bumper
 - a. Remove plastic valence underneath factory front bumper. *Note:* Use a pry tool to remove the clips holding it in place.
 - b. Disconnect all electrical connections to the stock front bumper.
 - c. Remove the eight bolts fastening the stock bumper to the frame. See **Figure 1**.
 - d. The Support Bracket Bolt on each side will need to be loosened. See **Figure 2**.

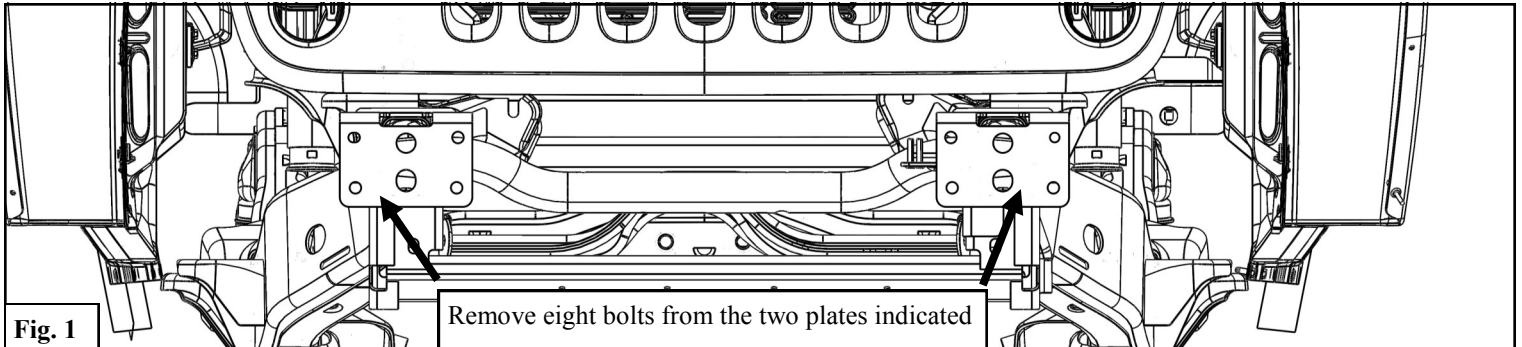

3. Loosely install the Driver and Passenger Mounting Brackets on to the inside of the frame reusing the factory hardware.
See **Figure 3**.

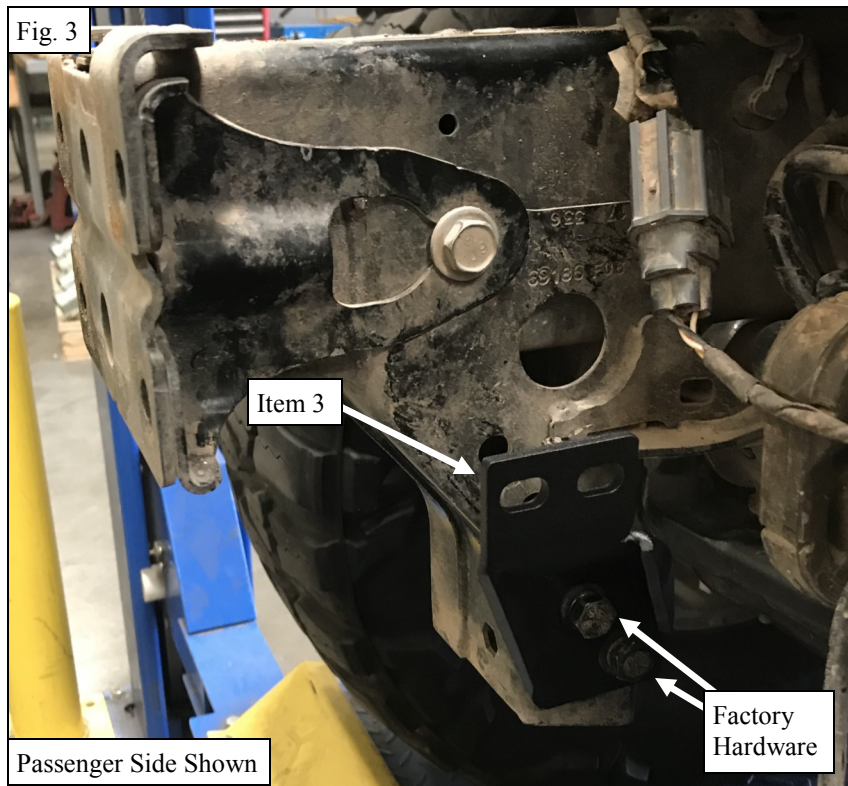

4. Using the supplied M8 hardware, mount the winch tray to the mounting brackets. See Figure 4

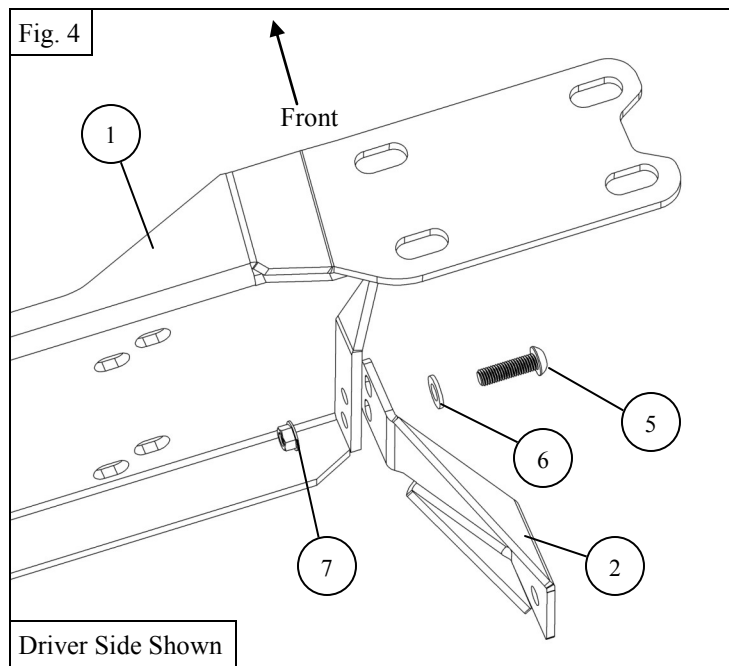

5. Remove the center plastic fairlead cover by pushing put or tapping with a hammer.
 6. Install the Fairlead Plate using the supplied M10 Hardware on to the factory bumper. See Figures 5-6.

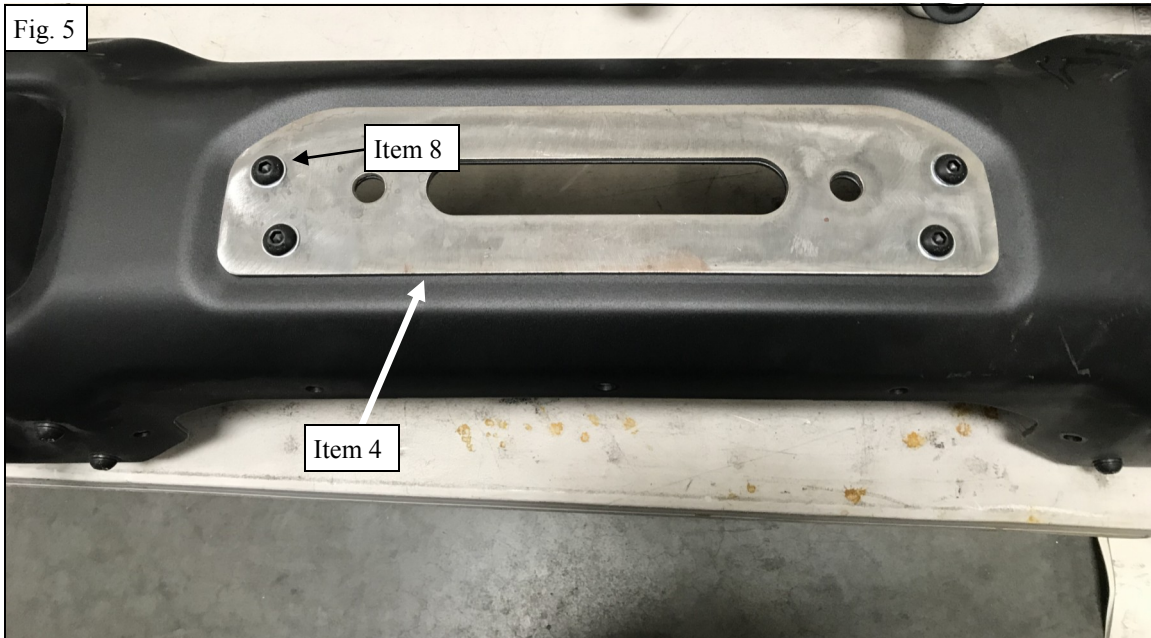

7. Tighten M8 hardware to 15-18 ft. lbs and M10 hardware to 30-35 ft-lbs.
8. Install winch per winch manufacturer's instructions.
9. Reinstall the factory bumper over the winch plate using the factory hardware. Torque factory M12 bolts to 69 ft. lbs

INSTALL COMPLETE



Winch sold separately

CARE INSTRUCTIONS

- REGULAR WAXING IS RECOMMENDED. DO NOT USE ANY TYPE OF POLISH OR WAX THAT MAY CONTAIN ABRASIVES.
- STAINLESS STEEL PRODUCTS CAN BE CLEANED WITH MILD SOAP AND WATER. STAINLESS STEEL POLISH SHOULD BE USED TO POLISH SMALL SCRATCHES.
- GLOSS BLACK FINISHES SHOULD BE CLEANED WITH MILD SOAP AND WATER.

WESTIN Westin Automotive Products, Inc.
320 W. Covina Blvd
San Dimas, Ca. 91773

Thank you for choosing Westin products
for additional installation assistance please call
Customer Service (800) 793-7846



WARNING



Failure to follow these instructions could lead to death, personal injury, and / or property damage.

Failure to follow these instructions could lead to death, personal injury, and / or property damage.

FASTENERS:

All Westin supplied fasteners must be utilized and installed in accordance with the installation instructions and apply torque to the specifications as defined. **DOUBLE CHECK ALL FASTENERS BEFORE INITIAL USE, AND PERIODICALLY IN THE FUTURE TO ENSURE PROPER FUNCTION AND SAFETY.**

DRILLING:

Most Westin products do not require drilling for installation. If drilling is defined as required, use caution when drilling a vehicle. **FAILURE TO REVIEW AN AREA TO BE DRILLED MAY RESULT IN PERSONAL INJURY AND/OR INJURY TO OTHERS AS WELL AS VEHICLE DAMAGE.**

EYE PROTECTION:

ALWAYS WEAR SAFETY GLASSES OR GOGGLES DURING THE INSTALLATION PROCESS TO AVOID PERSONAL INJURY.

MAXIMUM TOWING/CARRYING CAPACITY: (if applicable)

The Westin Receiver Hitches will have a visible tow rating label affixed directly on the product. User should never exceed the vehicle manufacturers maximum tow and weight rating regardless of the capacity of the hitch. **FAILURE TO FOLLOW THESE GUIDELINES WILL VOID THE WESTIN WARRANTY AND MAY RESULT IN PERSONAL INJURY AND/OR INJURY TO OTHERS AS WELL AS VEHICLE DAMAGE.**

FOR CALIFORNIA RESIDENTS ONLY-PROP 65 WARNING:

Some products may contain chemicals such as DEHP, which can cause cancer, birth defects or other reproductive harm. For more info go to www.p65warnings.ca.gov



Westin Automotive Products, Inc.
320 W. Covina Blvd
San Dimas, Ca. 91773